

PLATES

NOTE: Since the adoption of the 1994 Manual, there have been various design and procedural revisions. Many of the revisions are included under the Revisions link. Engineers and surveyors are encouraged to call the Bureau of Engineering to obtain the latest design criteria and procedures.

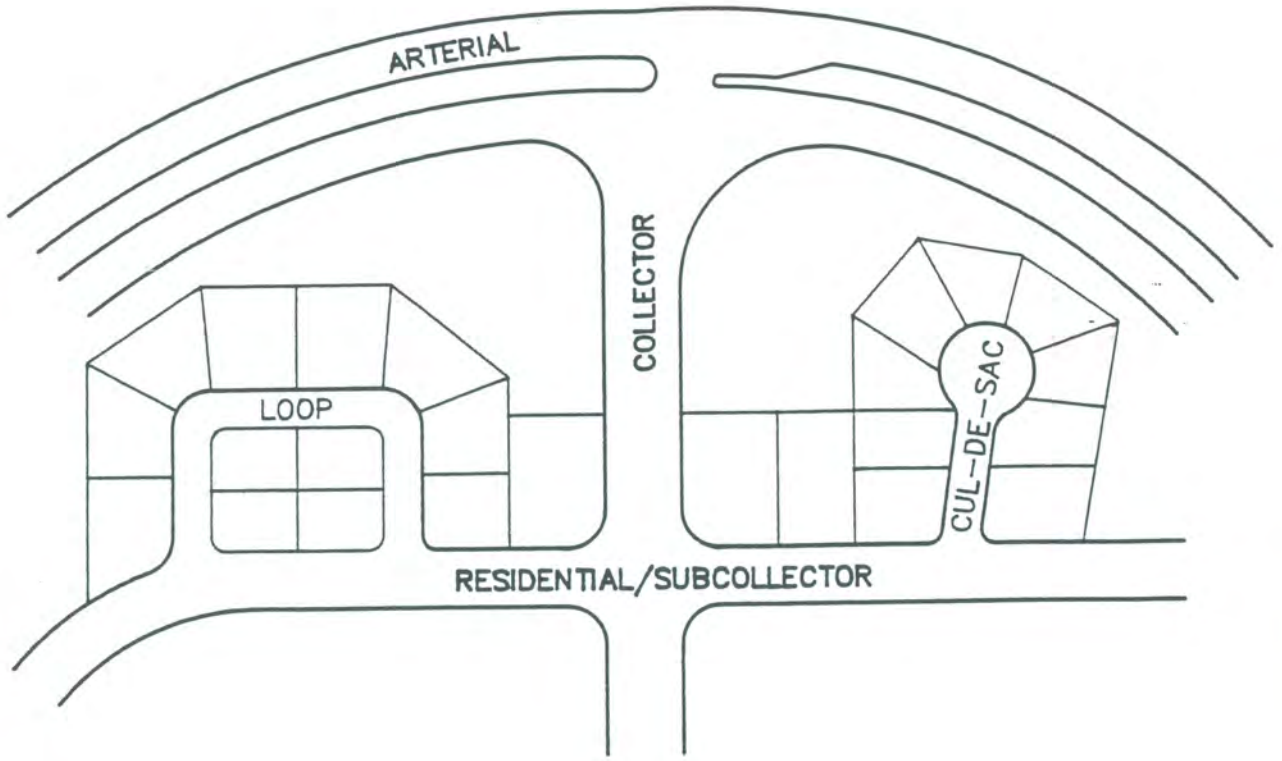

REVISED	
DATE	BY

CARROLL COUNTY, MARYLAND
 DEPARTMENT OF PUBLIC WORKS

Eric S. Cleveland 4-12-94
 DIRECTOR DATE

HIERARCHY OF STREETS
 SCHEMATIC

PLATE
 1

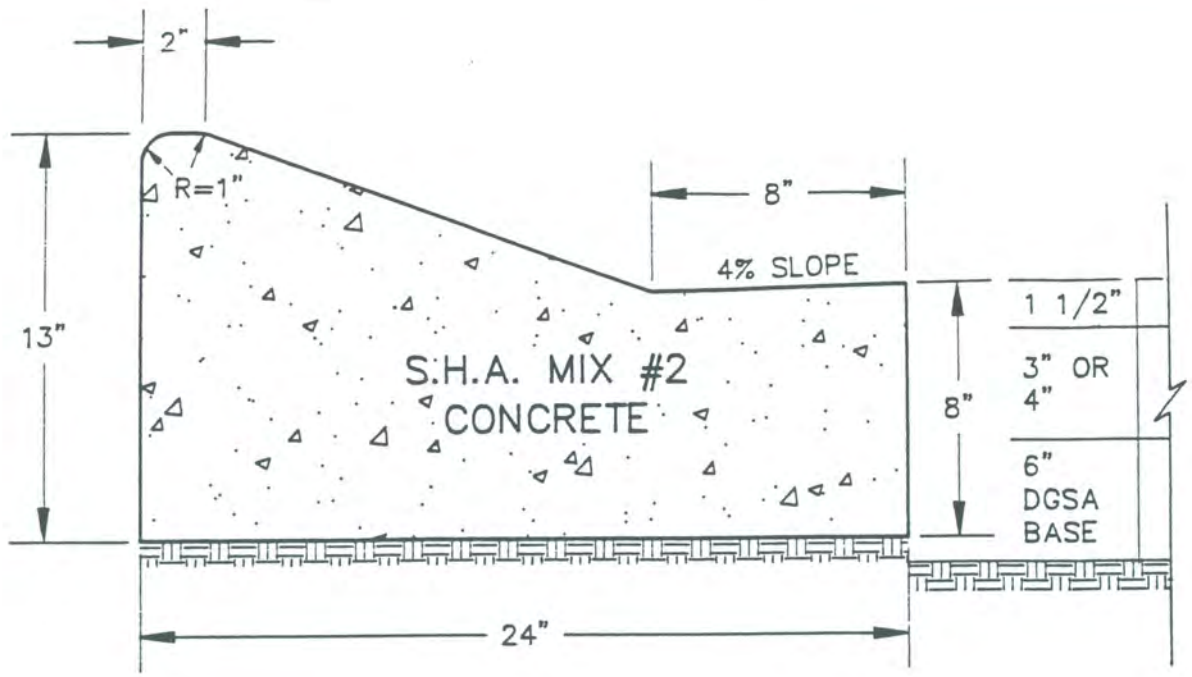

A = NORMAL SLOPE

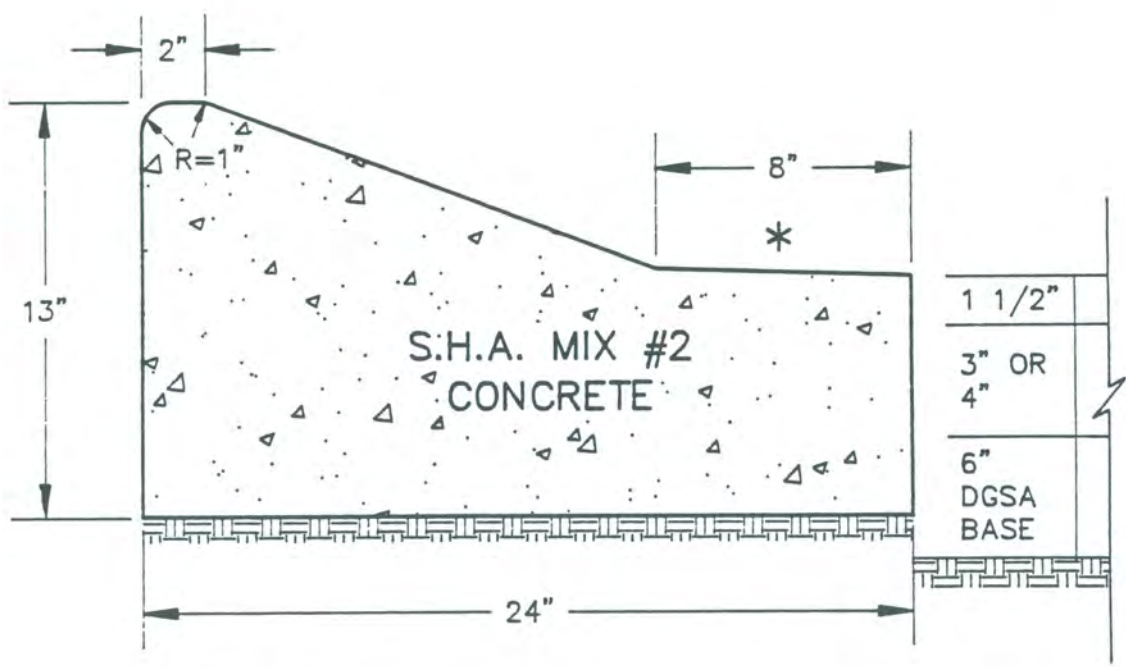

* SLOPE OF GUTTER
AS SHOWN ON PLANS

B = REVERSE SLOPE

REVISED	
DATE	BY

CARROLL COUNTY, MARYLAND
DEPARTMENT OF PUBLIC WORKS

Handwritten Signature 4-12-94
DIRECTOR DATE

MOUNTABLE CURB
AND GUTTER

PLATE
2

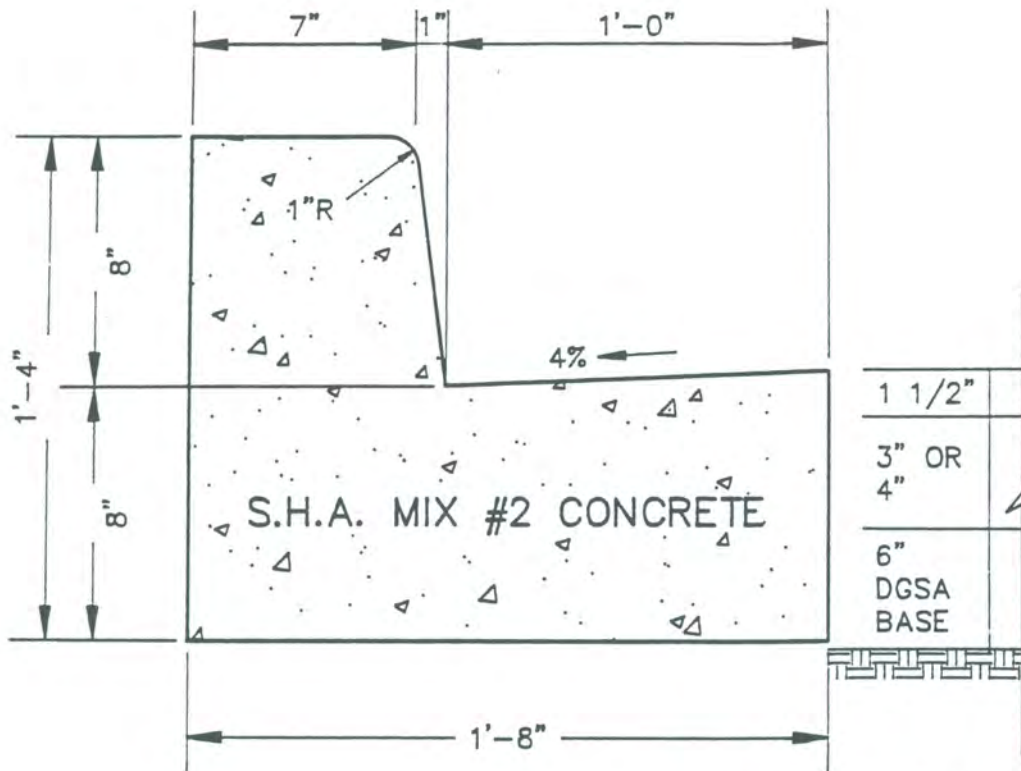

A: NORMAL SLOPE

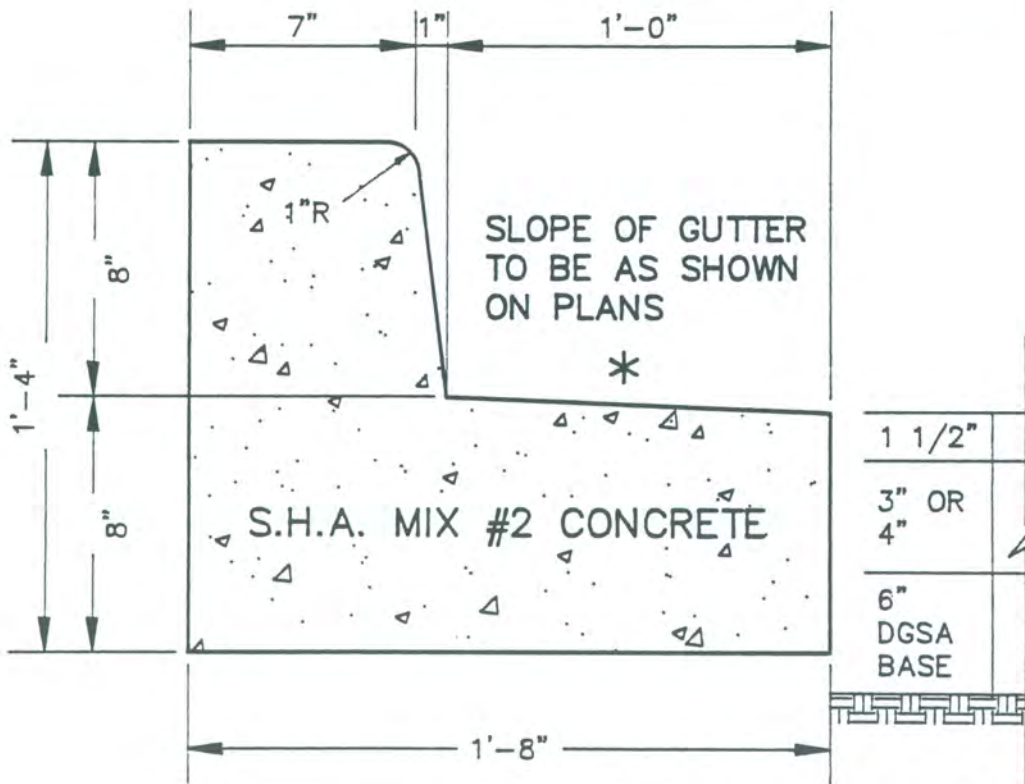

B: REVERSE SLOPE

REVISED	
DATE	BY

CARROLL COUNTY, MARYLAND
DEPARTMENT OF PUBLIC WORKS

Kevin St... 4-12-94
DIRECTOR DATE

8" COMBINATION
CURB AND GUTTER

PLATE

3

FINISHED GRADE BEHIND CURB TO
SLOPE UP FROM BACK OF CURB AT 1" PER
FOOT FOR 2' MIN.

RIGHT OF WAY LINE

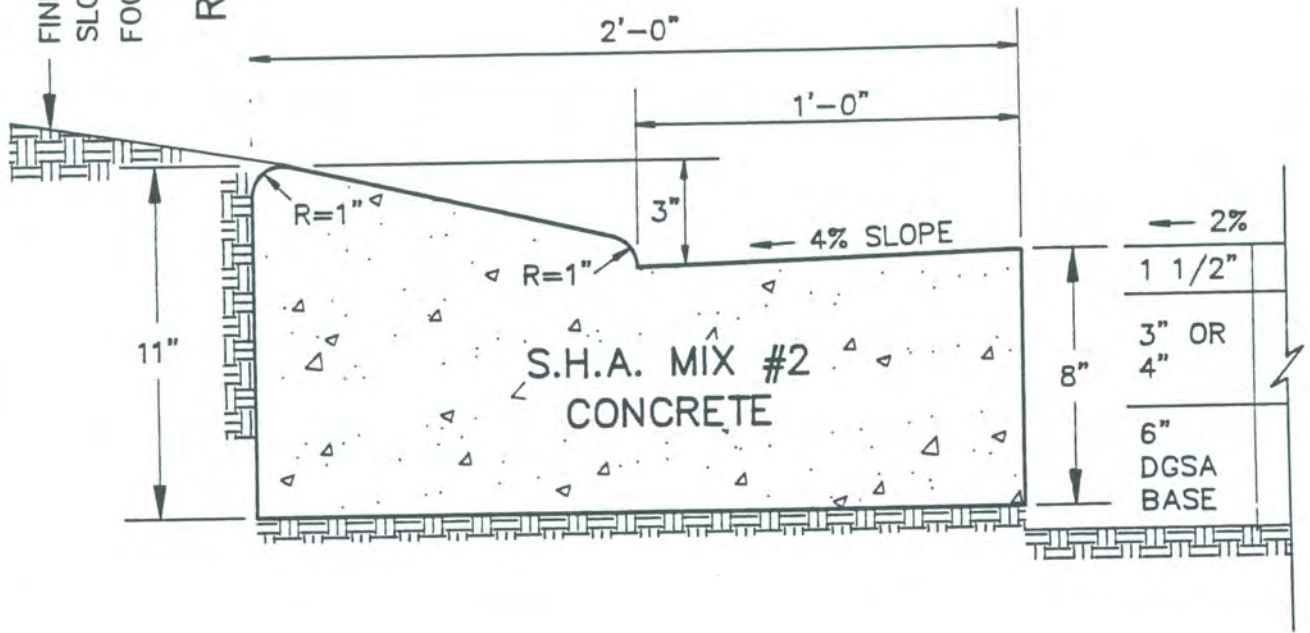

REVISED	
DATE	BY

CARROLL COUNTY, MARYLAND
DEPARTMENT OF PUBLIC WORKS

[Signature] 4-12-94
DIRECTOR DATE

MULTI-FAMILY DEVELOPEMENT

MODIFIED MOUNTABLE
CURB AND GUTTER

PLATE

4

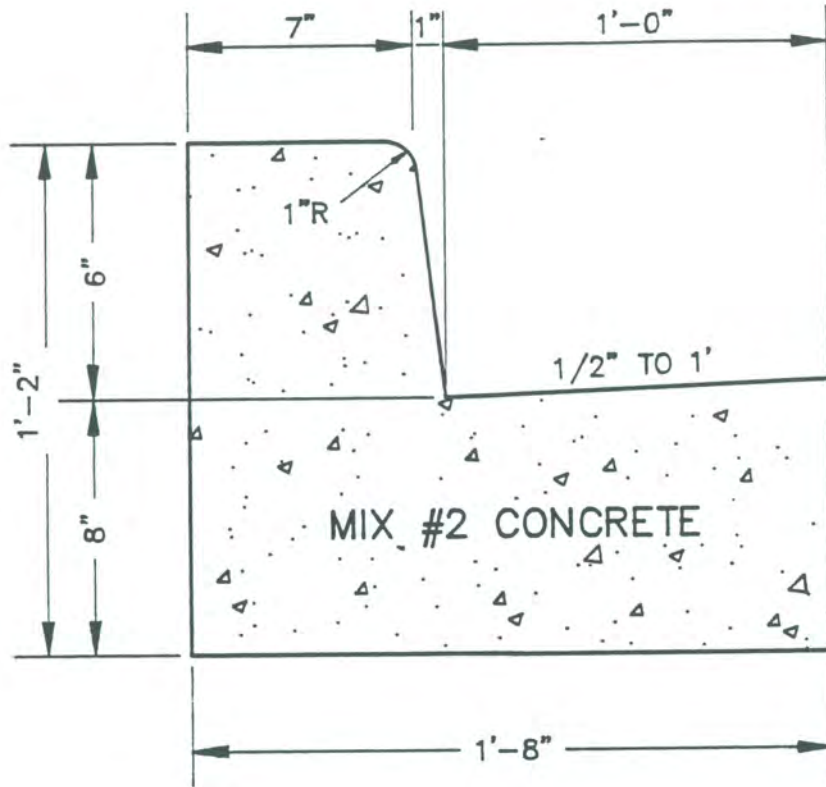

NOTE:
 GUTTER PAN SLOPE TO BE REVERSED TO MATCH ADJACENT
 PAVING SLOPE WHERE NOTED ON PLANS.

REVISED	
DATE	BY

CARROLL COUNTY, MARYLAND
 DEPARTMENT OF PUBLIC WORKS

Eric Stensland 4-12-94
 DIRECTOR DATE

MULTI-FAMILY DEVELOPMENT
 6" COMBINATION
 CURB AND GUTTER
 PARKING BAY LOCATION

PLATE

5

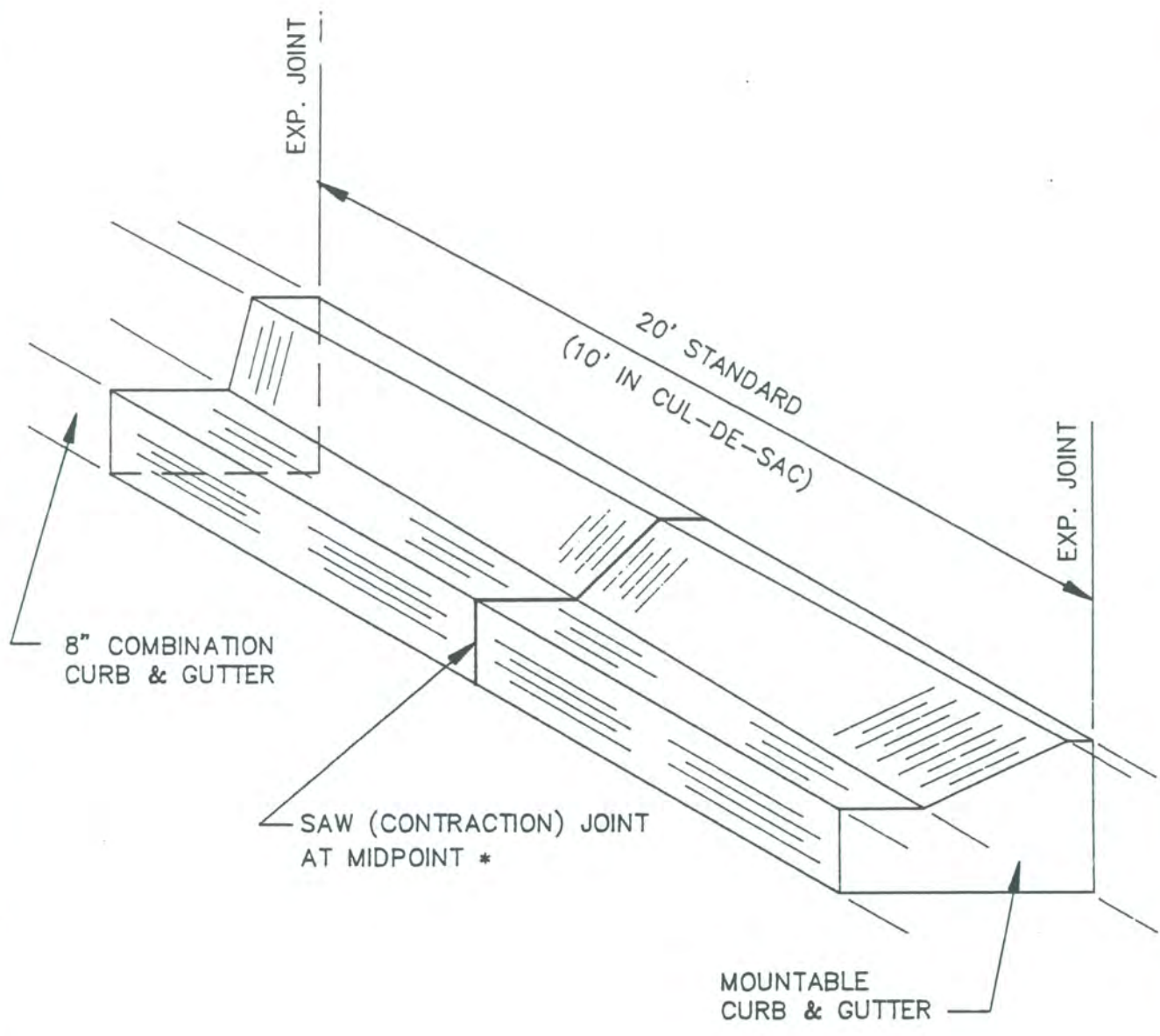

* CONTRACTION JOINT NOT NECESSARY IN 10' TRANSITIONS

REVISED	
DATE	BY

CARROLL COUNTY, MARYLAND
 DEPARTMENT OF PUBLIC WORKS

[Signature] 4-12-94
 DIRECTOR DATE

CURB TRANSITION SECTION
 FROM
 COMBINATION TO MOUNTABLE

PLATE
 6

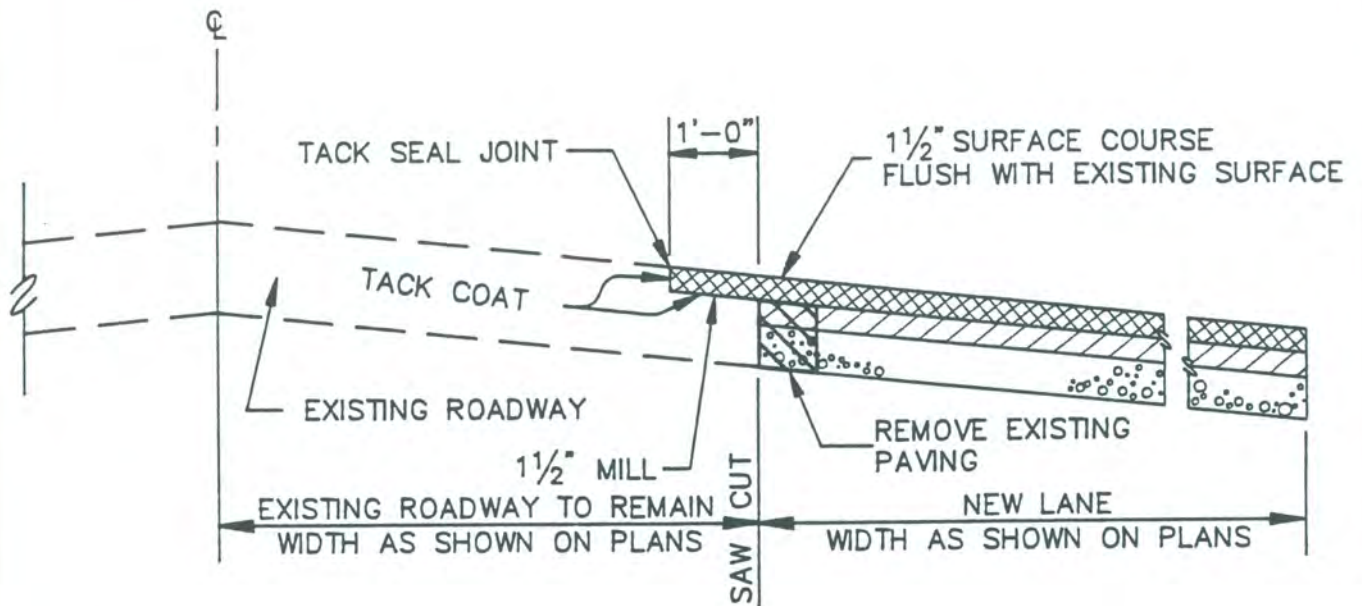

THIS METHOD OF JOINING SHALL BE USED WHERE A LANE IS BEING ADDED AND OVERLAY OF EXISTING ROAD IS NOT REQUIRED. CURBING OR SHOULDER SHALL BE SPECIFIED IN TYPICAL SECTION.

REVISED	
DATE	BY

CARROLL COUNTY, MARYLAND
DEPARTMENT OF PUBLIC WORKS

[Signature] 4-12-94
DIRECTOR DATE

PAVING JOINT

PLATE

7

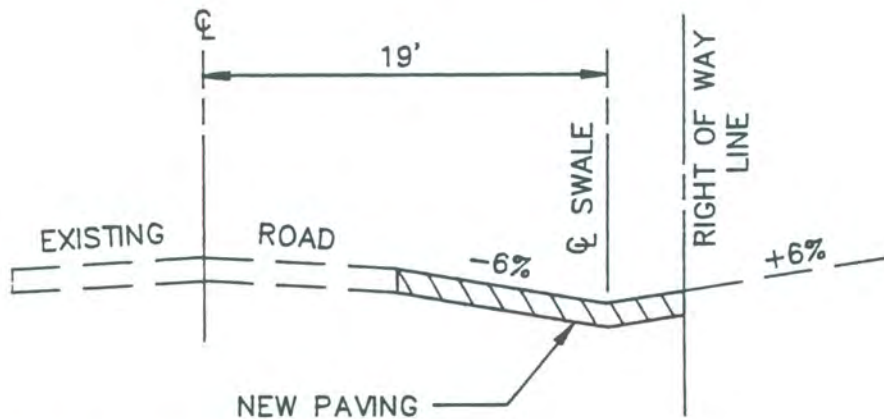
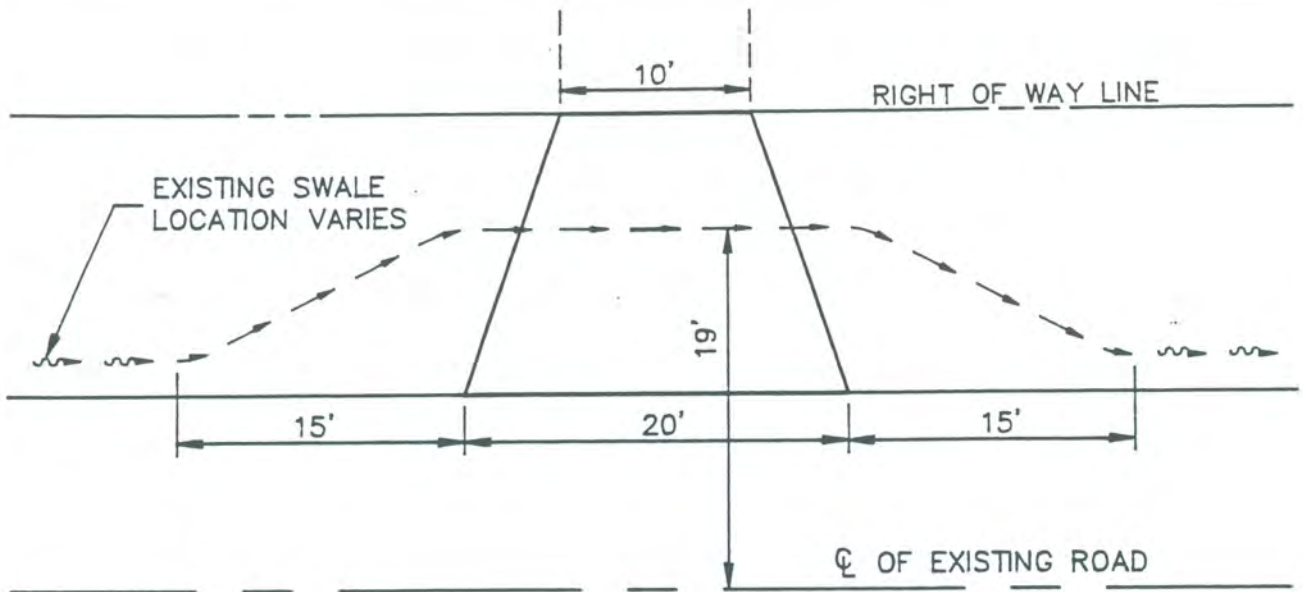

PAVING: 7" MIX No. 2 NON-REINFORCED CONCRETE

OR: 1½" BIT. CONC. SURF.
 3" BIT. CONC. BASE
 6" DGSA STONE BASE

NOTE:

1. SWALE APRONS MAY BE USED ONLY WHERE UPGRADE DRAINAGE AREA IS 1-3 ACRES OR DISTANCE TO CREST OF HILL IS LESS THAN 150 FEET.
2. APRON SHALL BE CONSTRUCTED FROM EDGE OF ROAD TO R.O.W. LINE. IF NO R.O.W. EXISTS APRON MUST EXTEND A MINIMUM OF 18' FROM EDGE OF ROAD.

REVISED	
DATE	BY

CARROLL COUNTY, MARYLAND
 DEPARTMENT OF PUBLIC WORKS

Keith Stinson 4-12-94
 DIRECTOR DATE

RESIDENTIAL DRIVEWAY
 APRON WITH SWALE

PLATE

8

PIPE CULVERT, WHEN REQUIRED,
 SHALL BE LOCATED AS SHOWN
 MIN. SIZE = 15"
 MIN. LENGTH = 30'
 MIN. COVER = 6" TOP OF PIPE TO BOTTOM OF APRON.
 MIN. GAUGE = 14(FOR METAL PIPE)

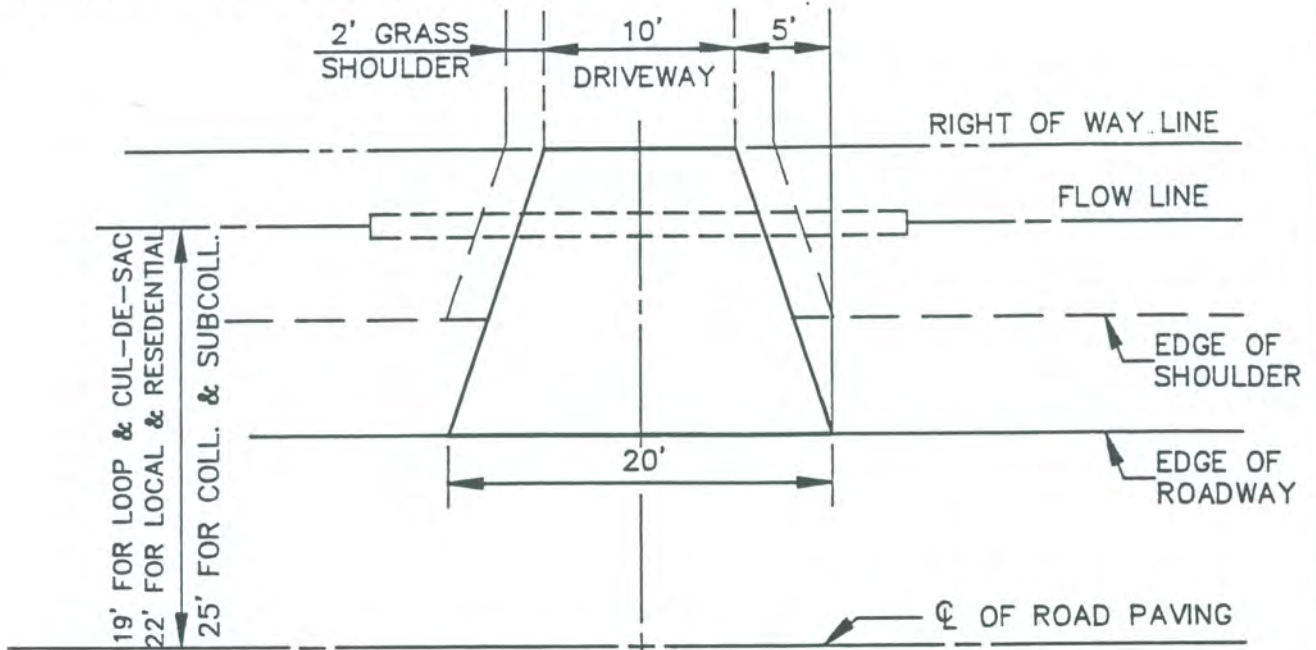

PLAN

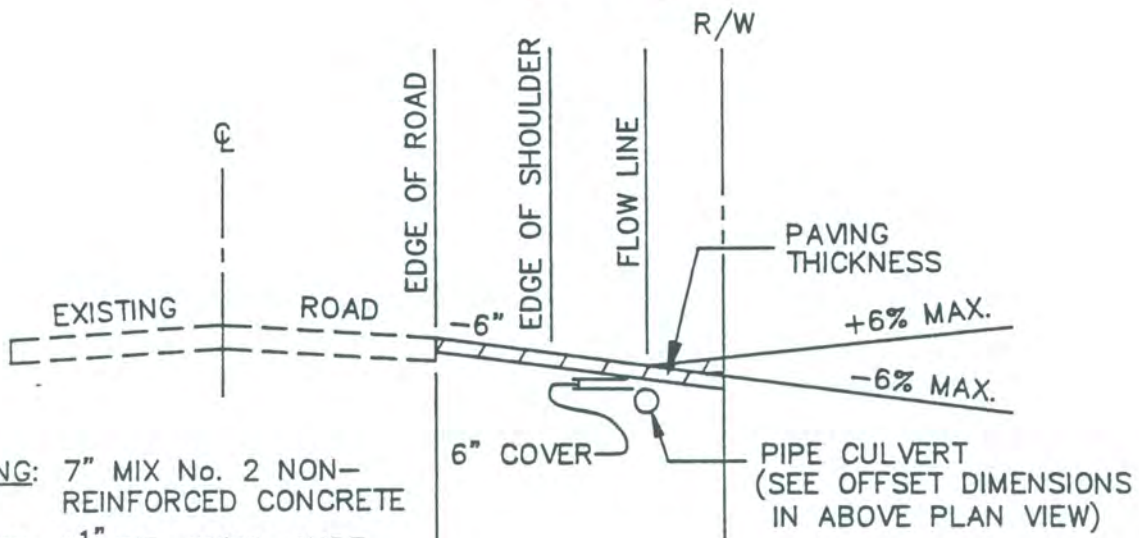

PAVING: 7" MIX No. 2 NON-REINFORCED CONCRETE
OR: 1 1/2" BIT. CONC. SURF.
 3" BIT. CONC. BASE
 6" DGSA STONE BASE

PROFILE

NOTE:
 APRON SHALL BE CONSTRUCTED FROM EDGE OF ROAD TO R.O.W. LINE.
 IF NO R.O.W. EXISTS APRON MUST EXTEND A MINIMUM OF 18' FROM EDGE OF ROAD.

REVISED	
DATE	BY

CARROLL COUNTY, MARYLAND
 DEPARTMENT OF PUBLIC WORKS

K. J. ... 4-12-94
 DIRECTOR DATE

RESIDENTIAL DRIVEWAY
 APRON
 SINGLE USE WITH CULVERT

PLATE

9

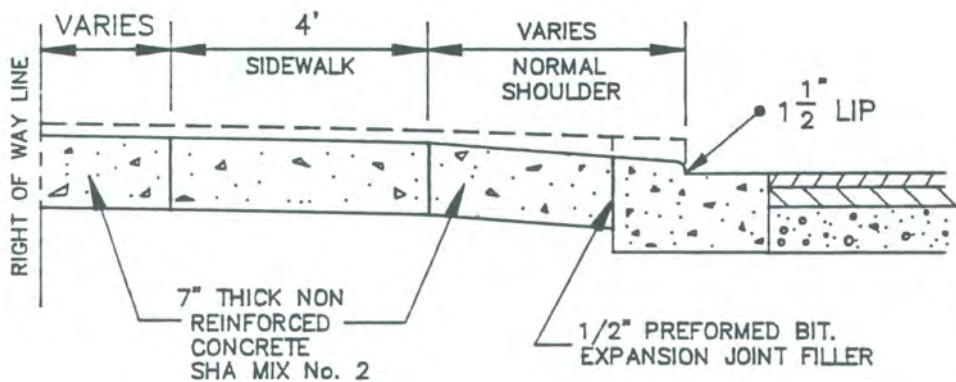
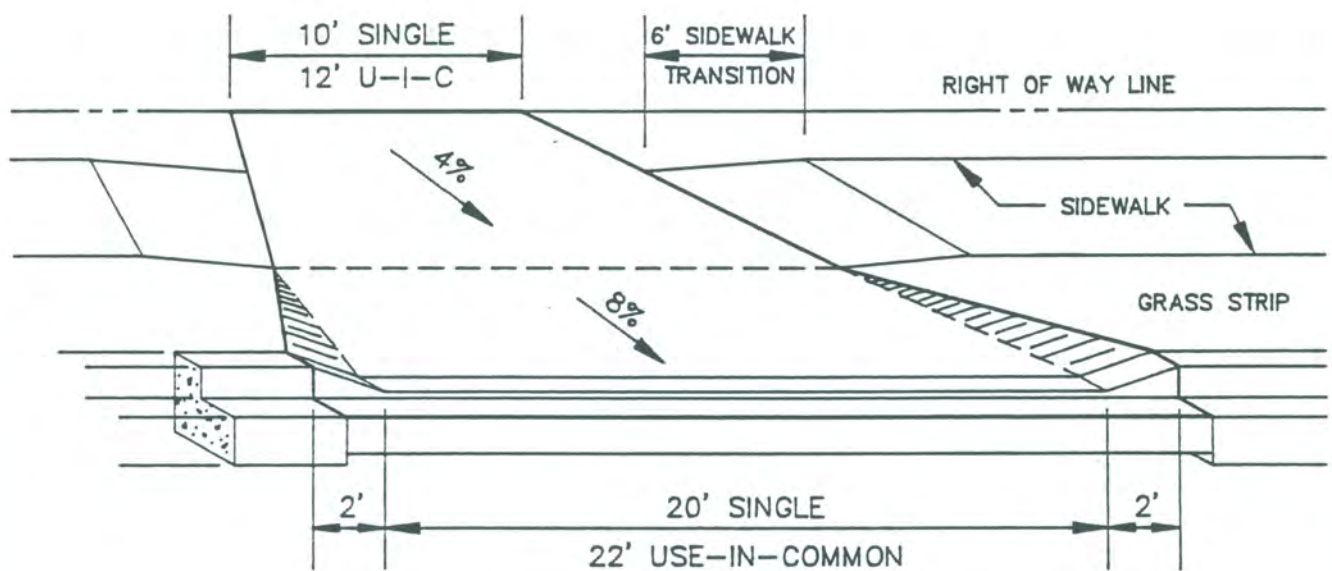
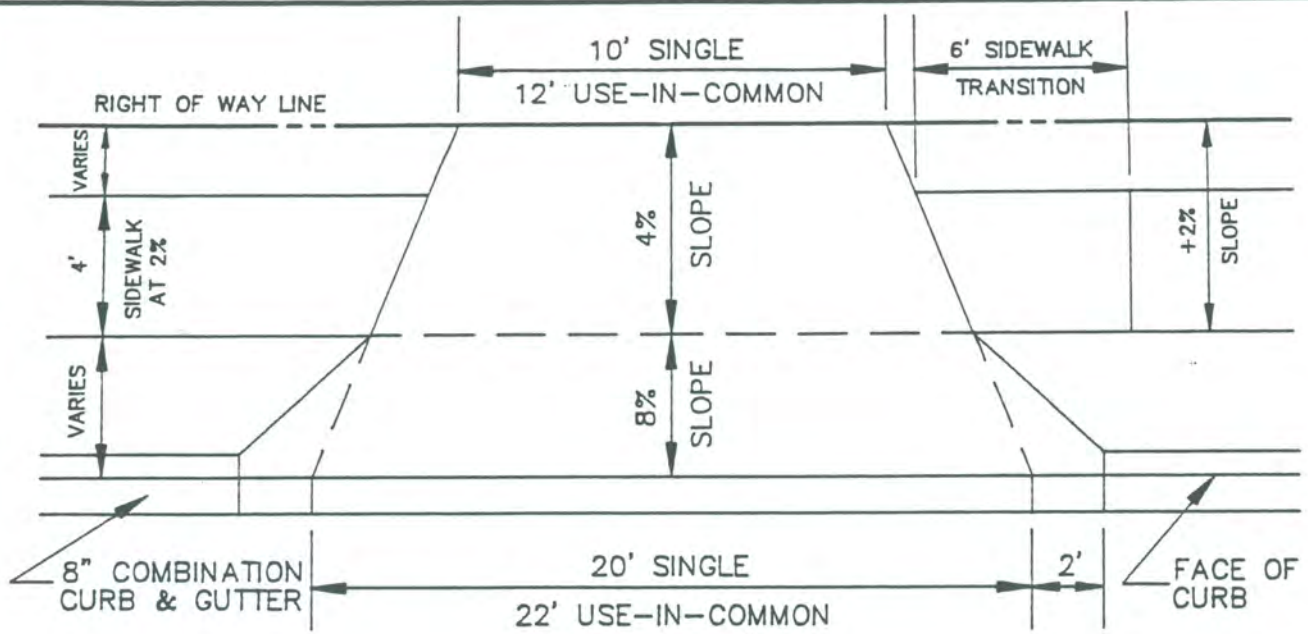

REVISED	
DATE	BY

CARROLL COUNTY, MARYLAND
DEPARTMENT OF PUBLIC WORKS

[Signature]
DIRECTOR

4-12-94
DATE

SINGLE AND USE-IN-COMMON
DRIVEWAY APRONS
WITH 8" COMBINATION C & G

PLATE
10

PIPE CULVERT, WHEN REQUIRED,
 SHALL BE LOCATED AS SHOWN
 MIN. SIZE = 15"
 MIN. LENGTH = 30'
 MIN. COVER = 6" TOP OF PIPE
 TO BOTTOM OF
 APRON.
 MIN. GAUGE = 14(FOR METAL PIPE)

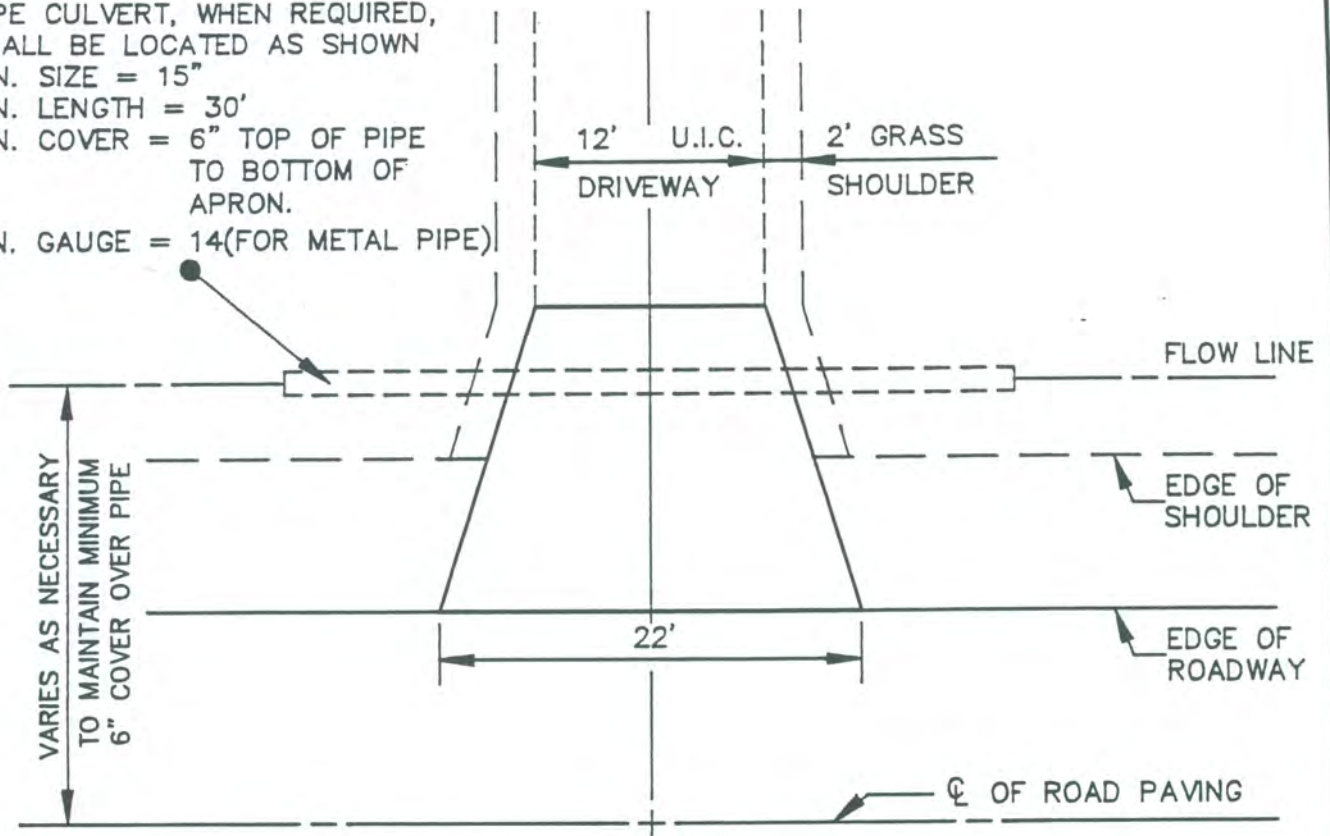

PLAN

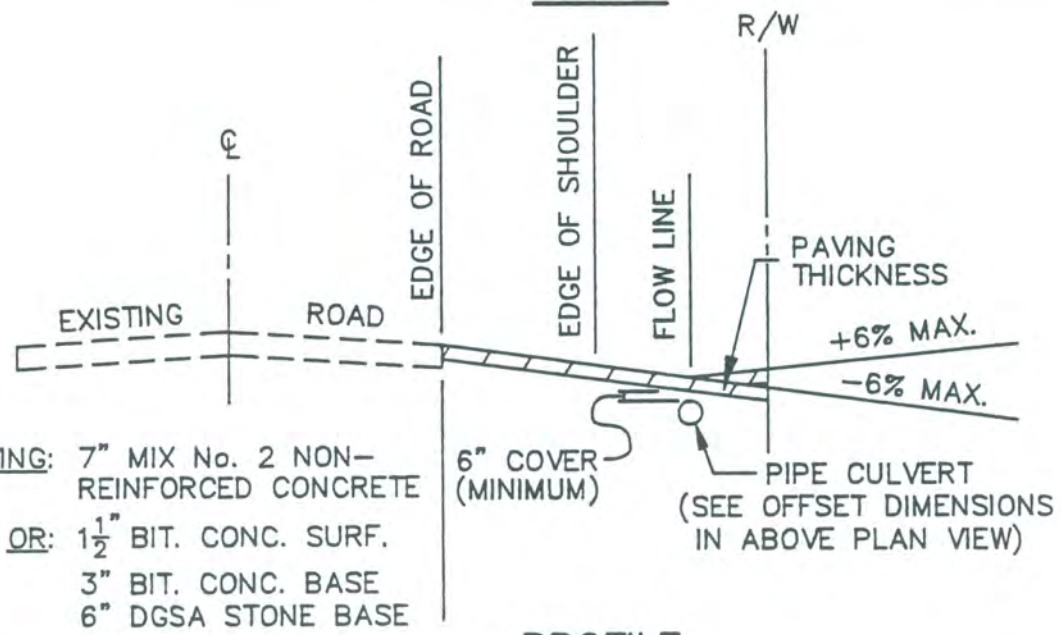

PAVING: 7" MIX No. 2 NON-
 REINFORCED CONCRETE
OR: 1 1/2" BIT. CONC. SURF.
 3" BIT. CONC. BASE
 6" DGSA STONE BASE

PROFILE

NOTE:
 APRON SHALL BE CONSTRUCTED FROM EDGE OF ROAD TO R.O.W. LINE.
 IF NO R.O.W. EXISTS APRON MUST EXTEND A MINIMUM OF 18' FROM EDGE
 OF ROAD.

REVISED	
DATE	BY

CARROLL COUNTY, MARYLAND
 DEPARTMENT OF PUBLIC WORKS
Carroll County
 DIRECTOR
 4-12-94
 DATE

RESIDENTIAL DRIVEWAY
 APRON USE IN COMMON
 WITH CULVERT

PLATE
 11

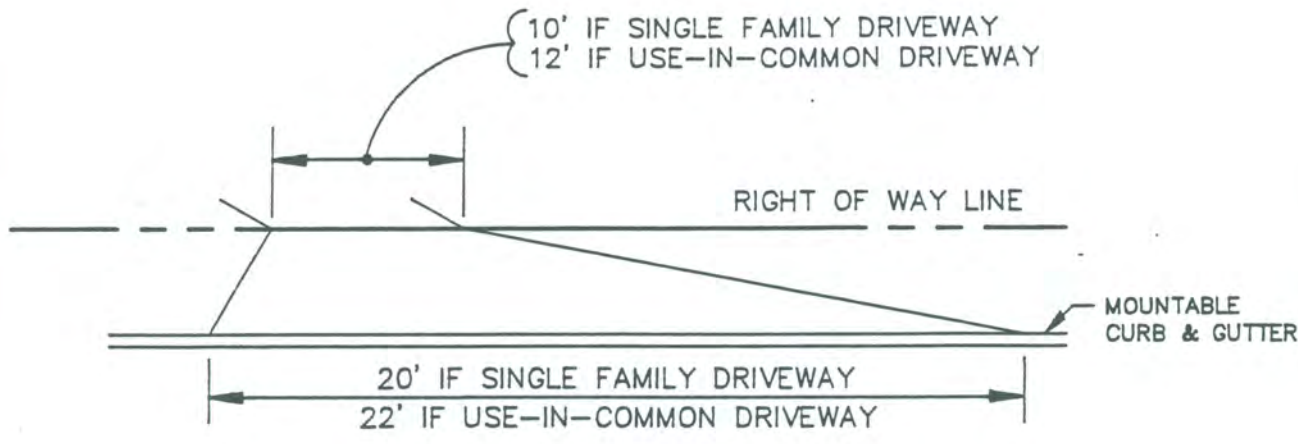

NOTE: SEE PLATES 8 AND 9 FOR PAVING COURSES.

PLAN

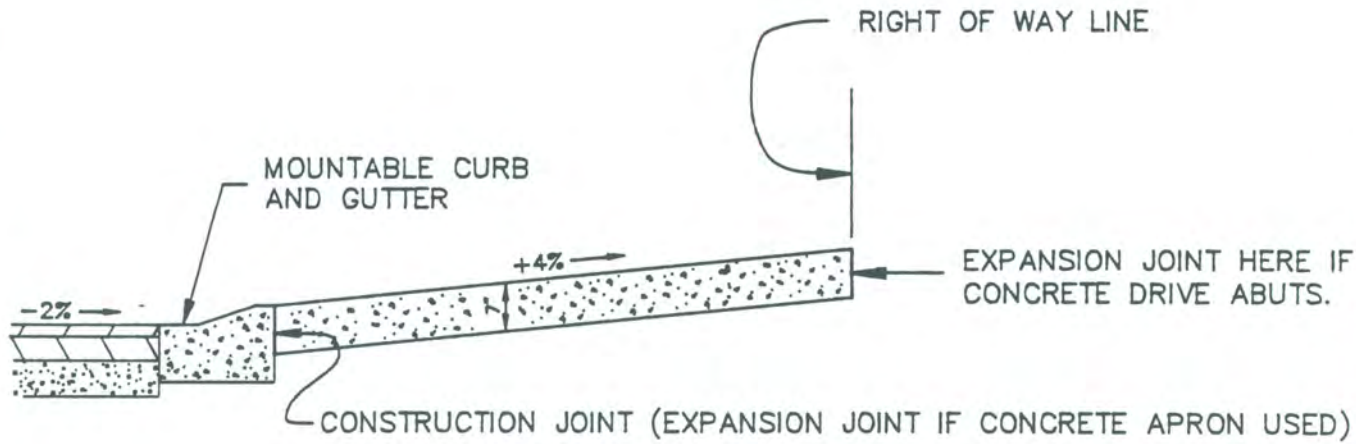

TYPICAL CROSS SECTION

PROFILE

REVISED	
DATE	BY

CARROLL COUNTY, MARYLAND
 DEPARTMENT OF PUBLIC WORKS
Carroll County 4-12-94
 DIRECTOR DATE

RESIDENTIAL DRIVEWAY
 APRONS WITH MOUNTABLE
 CURB AND GUTTER

PLATE
 12

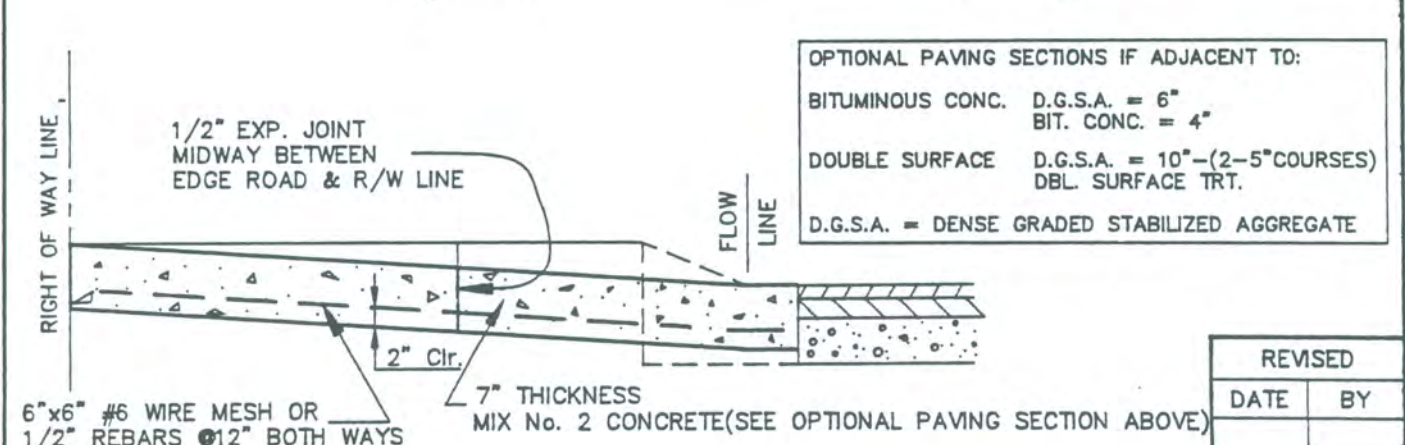
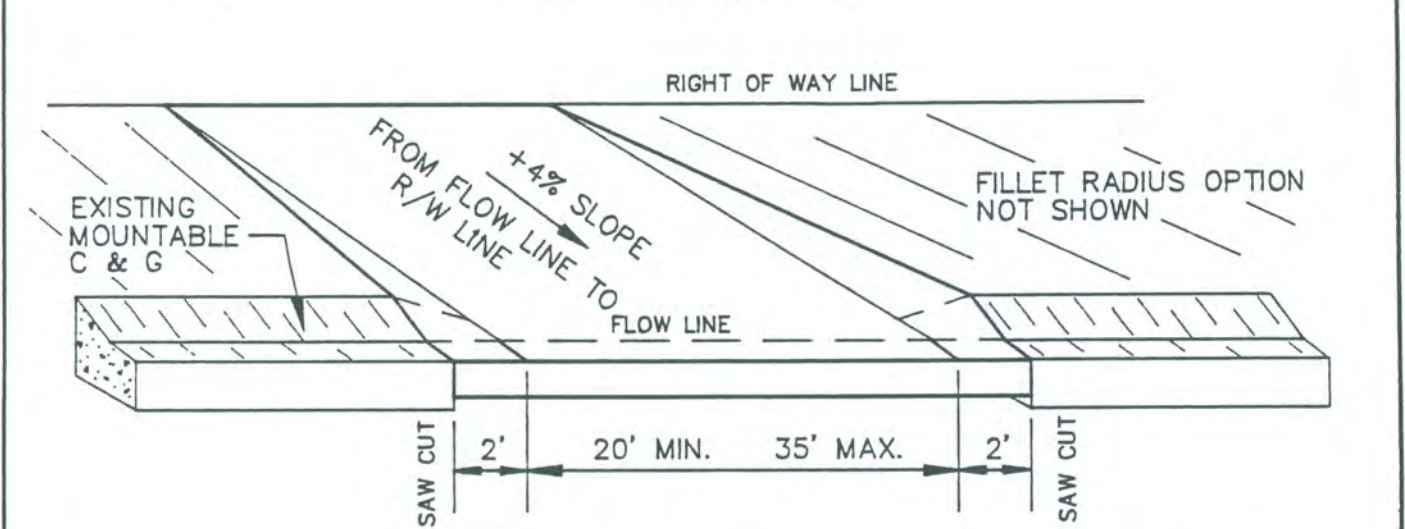
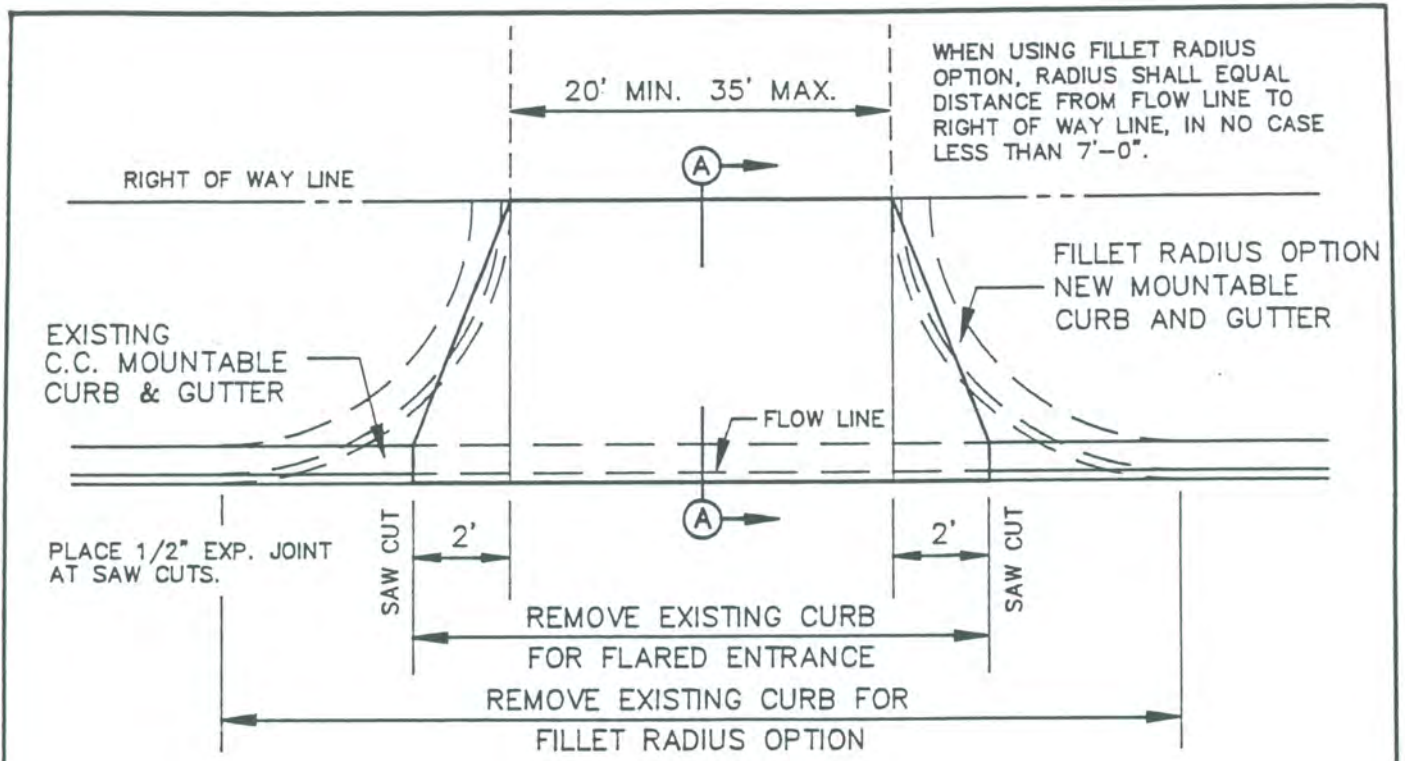

OPTIONAL PAVING SECTIONS IF ADJACENT TO:

BITUMINOUS CONC. D.G.S.A. = 6"
BIT. CONC. = 4"

DOUBLE SURFACE D.G.S.A. = 10"-(2-5" COURSES)
DBL. SURFACE TRT.

D.G.S.A. = DENSE GRADED STABILIZED AGGREGATE

SECTION A-A

CARROLL COUNTY, MARYLAND
DEPARTMENT OF PUBLIC WORKS

[Signature] 4-12-94
DIRECTOR DATE

COMMERCIAL ENTRANCE
WITH EXISTING MOUNTABLE
CURB AND GUTTER

REVISED	
DATE	BY
PLATE	
13	

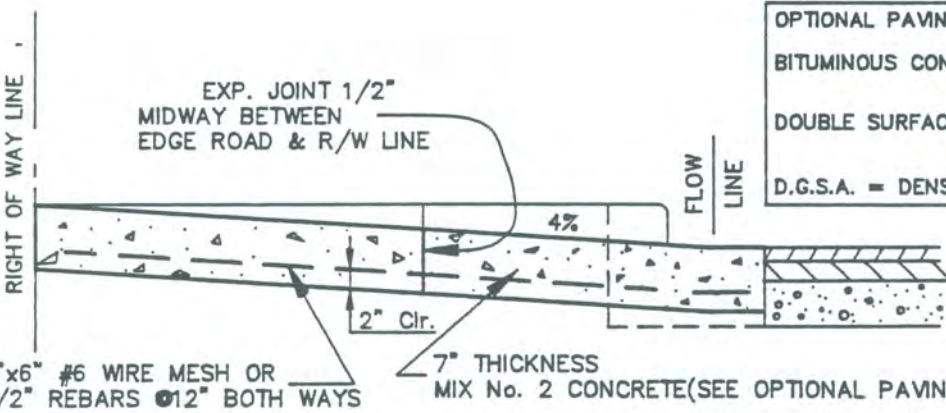
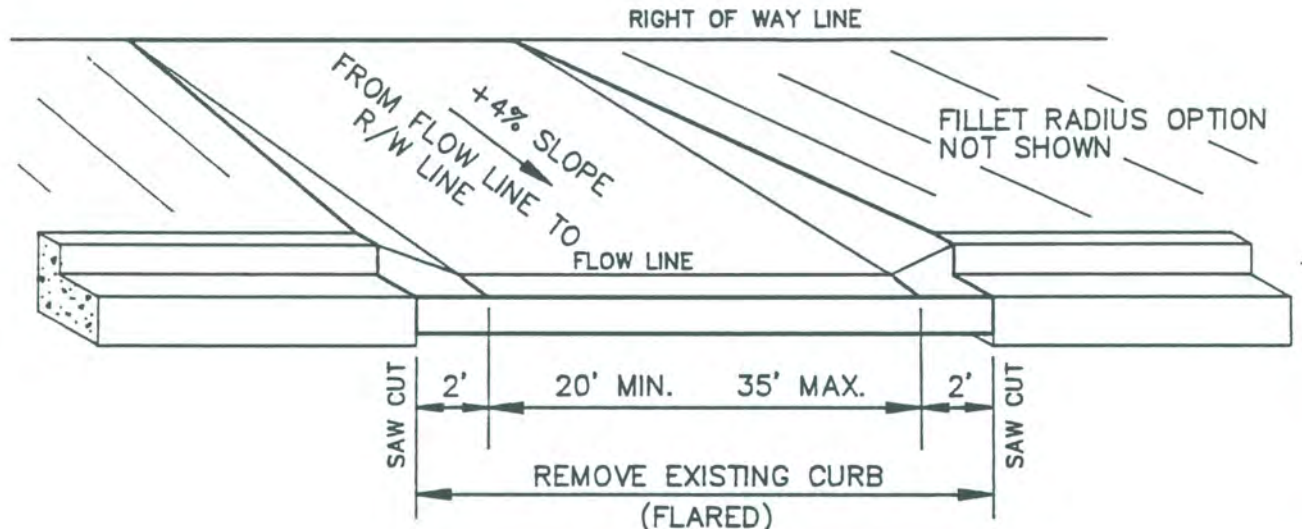
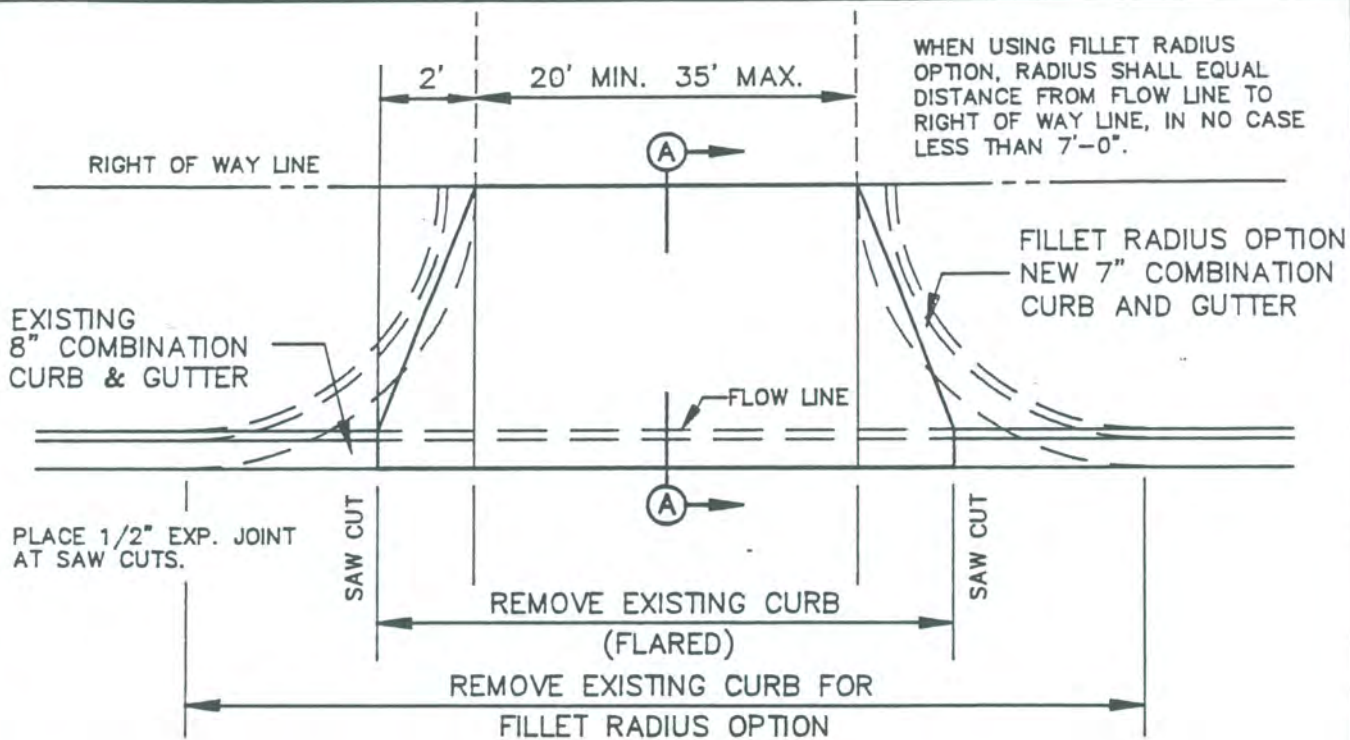

OPTIONAL PAVING SECTIONS IF ADJACENT TO:

BITUMINOUS CONC.	D.G.S.A. = 6"
	BIT. CONC. = 4"
DOUBLE SURFACE	D.G.S.A. = 10"-(2-5" COURSES)
	DBL. SURFACE TRT.
D.G.S.A. = DENSE GRADED STABILIZED AGGREGATE	

6"x6" #6 WIRE MESH OR 1/2" REBARS @12" BOTH WAYS 7" THICKNESS MIX No. 2 CONCRETE(SEE OPTIONAL PAVING SECTION ABOVE)

SECTION A-A

CARROLL COUNTY, MARYLAND
DEPARTMENT OF PUBLIC WORKS
Eastwood 4-12-94
DIRECTOR DATE

COMMERCIAL ENTRANCE WITH
EXISTING 8" COMBINATION
CURB AND GUTTER

REVISED	
DATE	BY
PLATE	
14	

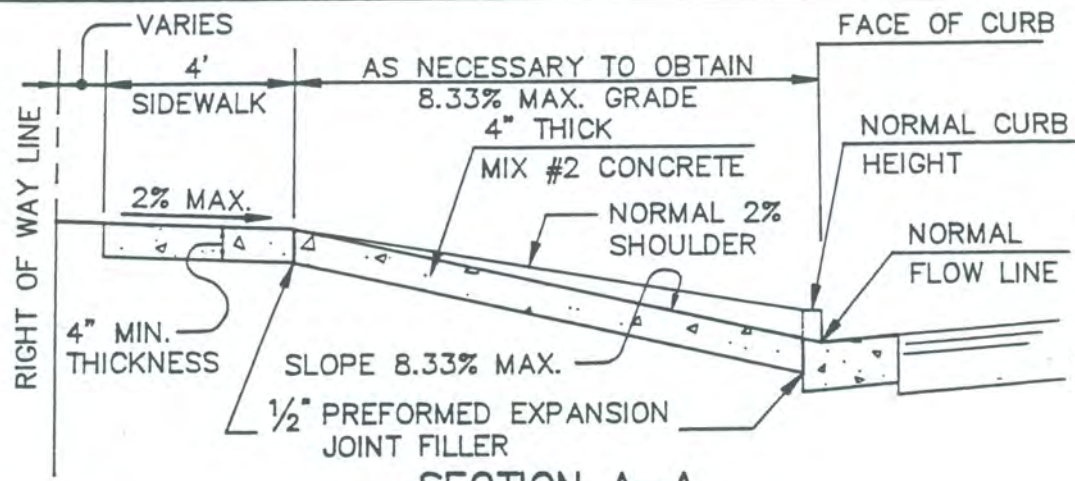

SECTION A-A

GENERAL NOTES:

1. CONSTRUCT 1/4" CONTRACTION JOINTS AT 4'-0" INTERVALS.
2. CONSTRUCT 1/2" PREMOLDED EXPANSION JOINTS AT 100' INTERVALS AT DRIVEWAYS, SIDEWALKS, CURBS, POLES OR ANY OTHER PERMANENT STRUCTURE.
3. A MONOLITHIC CONCRETE FOOTER, 6" THICK, 6" DEEP, FULL WIDTH OF THE SIDEWALK SHALL BE CONSTRUCTED AT 50' INTERVALS, APPROXIMATELY HALFWAY BETWEEN EXPANSION JOINT ON GRADES OF 5% OR OVER.
4. SURFACE OF RAMP AND FLARES SHALL HAVE COARSE TACTILE WARNING TEXTURE DONE WITH BROOM OR AN EQUIVALENT NON-SKID FINISH AS APPROVED BY D.P.W.
5. THIS DETAIL PRESENTS PREFERRED METHOD OF SIDEWALK RAMP CONSTRUCTION. ANY ALTERATIONS TO THIS DESIGN MUST CONFORM TO A.D.A. REQUIREMENTS.

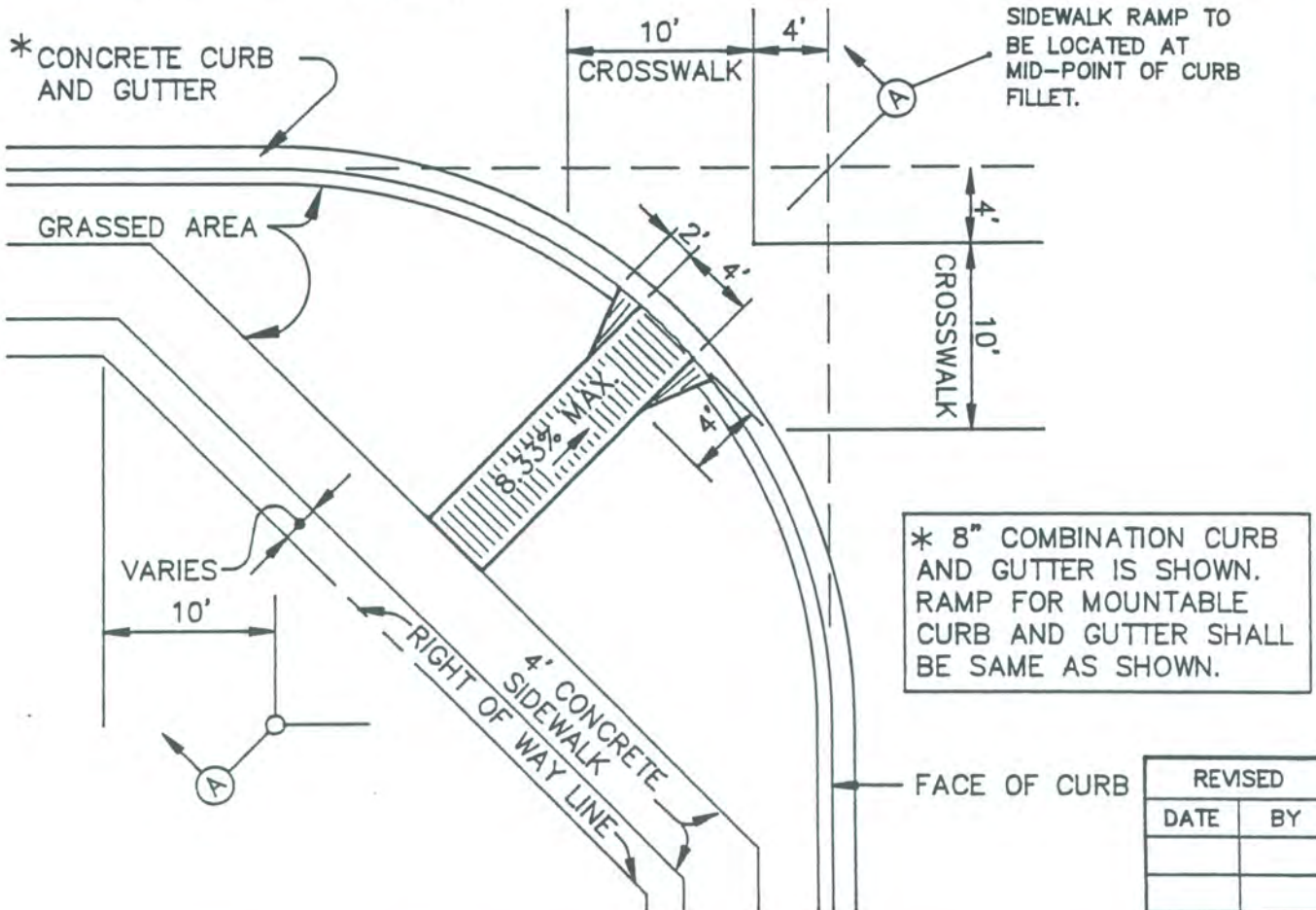

REVISED	
DATE	BY

CARROLL COUNTY, MARYLAND
DEPARTMENT OF PUBLIC WORKS

Kent D. ... 4-12-94
DIRECTOR DATE

SIDEWALK RAMP

PLATE

15

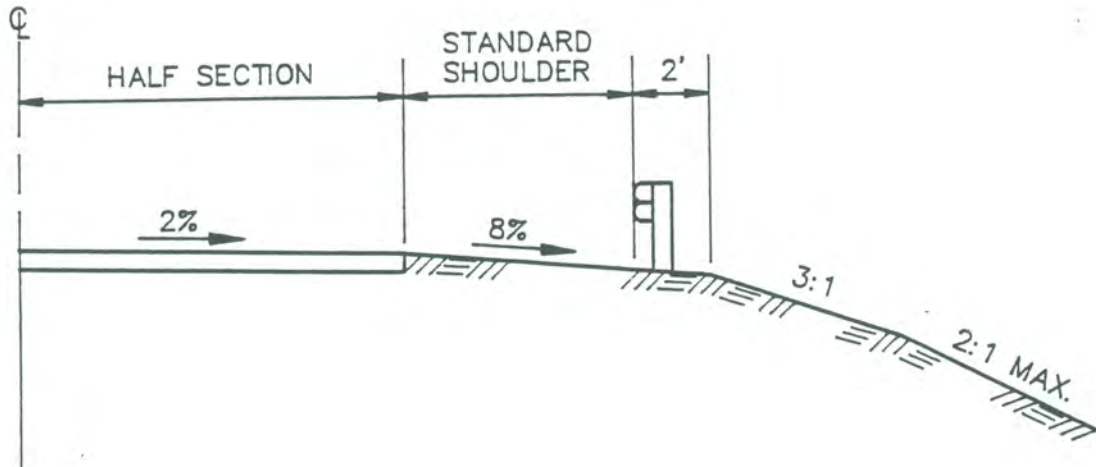

NOTES:

1. WHEN USING GUARDRAIL, HOLD SAME NORMAL SHOULDER SLOPE AND INCREASE AN ADDITIONAL 2' TO ALLOW FOR PLACEMENT AND BACKING.
2. SEE SECTION 2.7.6 OF THIS MANUAL FOR INFORMATION ON GUARDRAIL.

REVISED	
DATE	BY

CARROLL COUNTY, MARYLAND
 DEPARTMENT OF PUBLIC WORKS
W. D. Kinard 4-12-94
 DIRECTOR DATE

GUARDRAIL PLACEMENT

PLATE
 15-A

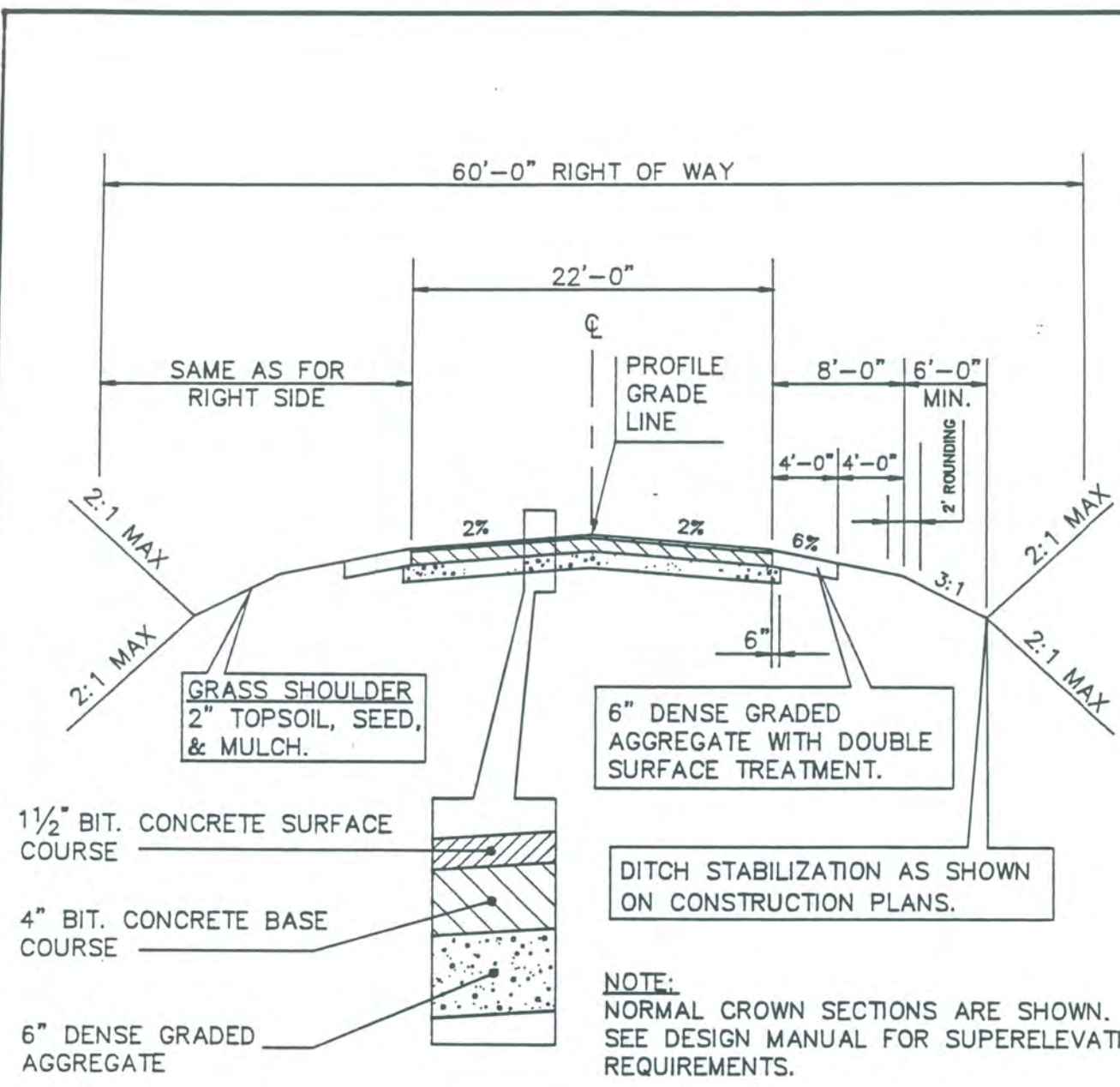

ALL DISTURBED AREAS WITHIN RIGHT OF WAY OR EASEMENT LIMITS NEEDED FOR ROADWAY CONSTRUCTION SHALL BE SODDED OR SEEDED AND MULCHED ON 2" OF TOPSOIL.

NOTE:
THIS TYPICAL SECTION SHALL BE USED IN THE FOLLOWING ZONES WHEN A COLLECTOR ROAD IS REQUIRED: R-40,000 AGRICULTURAL CONSERVATION

OVER 1000 ADT

REVISED	
DATE	BY

CARROLL COUNTY, MARYLAND
DEPARTMENT OF PUBLIC WORKS

Continued 4-12-94
DIRECTOR DATE

SUBCOLLECTOR ROAD
22' OPEN SECTION

PLATE
16

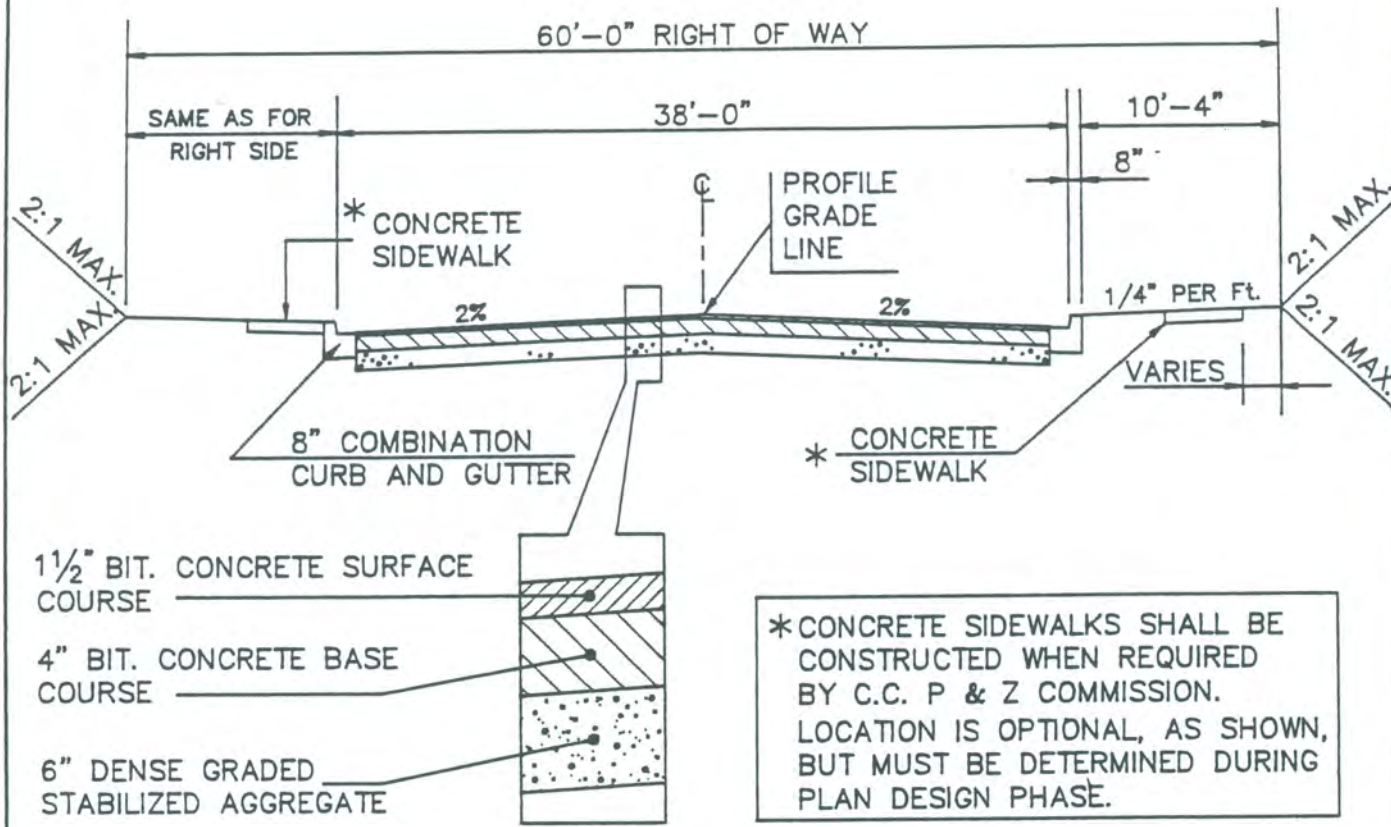

ALL DISTURBED AREAS WITHIN RIGHT OF WAY OR EASEMENT LIMITS NEEDED FOR ROADWAY CONSTRUCTION SHALL BE SODDED OR SEEDD AND MULCHED ON 2" OF TOPSOIL.

NOTE:

THIS TYPICAL SECTION SHALL BE USED IN THE FOLLOWING RESIDENTIAL ZONES WHEN A COLLECTOR ROAD IS REQUIRED:

- R-20,000
- R-10,000
- R-7,500

OVER 1000 ADT

REVISED	
DATE	BY

CARROLL COUNTY, MARYLAND
DEPARTMENT OF PUBLIC WORKS

[Signature] 4-12-94
DIRECTOR DATE

SUBCOLLECTOR ROAD
38' CLOSED SECTION

PLATE
17

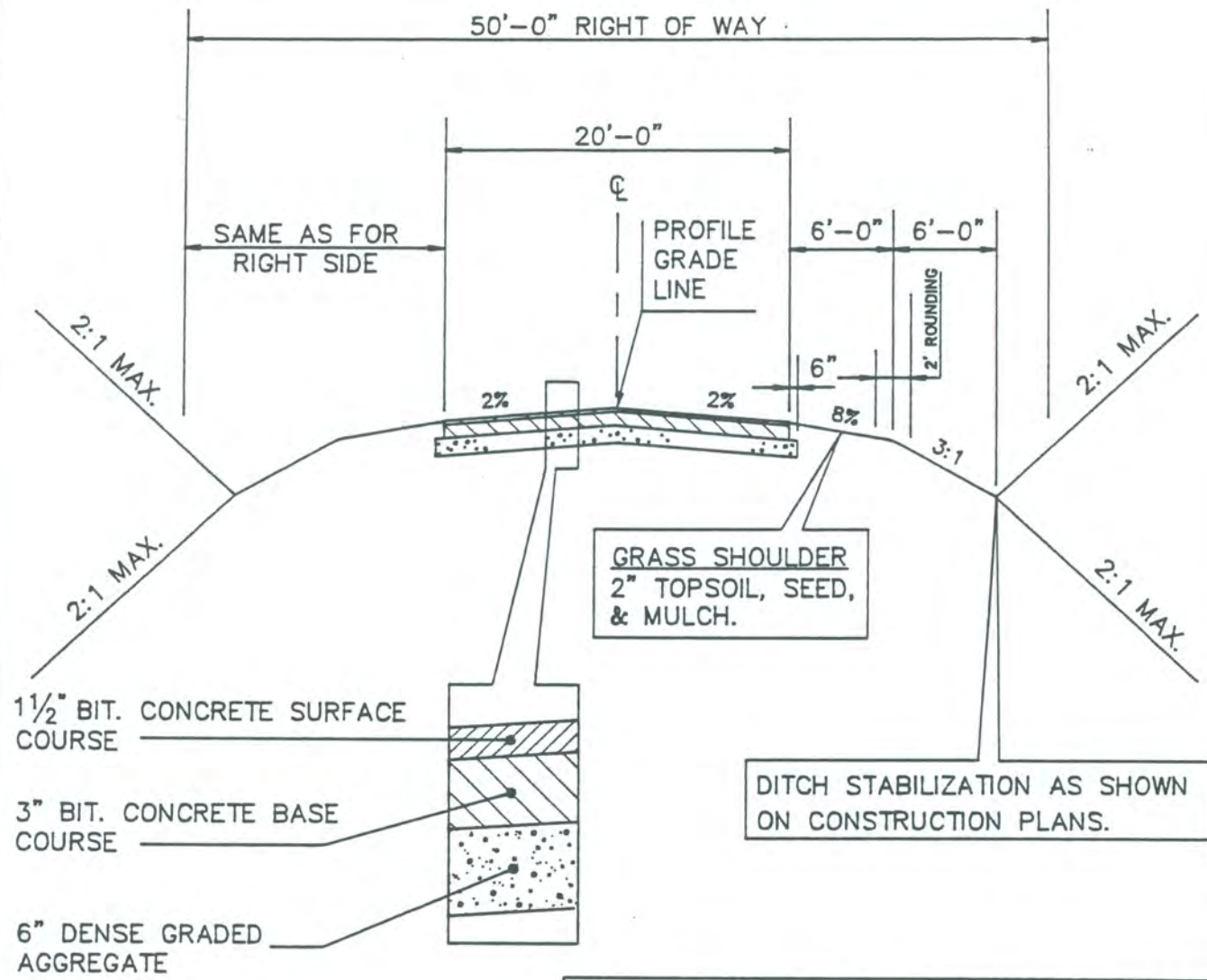

1 1/2" BIT. CONCRETE SURFACE COURSE

3" BIT. CONCRETE BASE COURSE

6" DENSE GRADED AGGREGATE

GRASS SHOULDER
2" TOPSOIL, SEED,
& MULCH.

DITCH STABILIZATION AS SHOWN
ON CONSTRUCTION PLANS.

ALL DISTURBED AREAS WITHIN RIGHT OF WAY
OR EASEMENT LIMITS NEEDED FOR ROADWAY
CONSTRUCTION SHALL BE SODDED OR SEEDED
AND MULCHED ON 2" OF TOPSOIL.

NOTE:
THIS TYPICAL SECTION SHALL BE USED IN
THE FOLLOWING ZONES WHEN A LOCAL ROAD
IS REQUIRED: R-40,000
AGRICULTURAL
CONSERVATION

MAX. ADT = 1000

REVISED	
DATE	BY

CARROLL COUNTY, MARYLAND
DEPARTMENT OF PUBLIC WORKS

K. Stinson 4-12-94
DIRECTOR DATE

RESIDENTIAL STREET
20' OPEN SECTION

PLATE
18

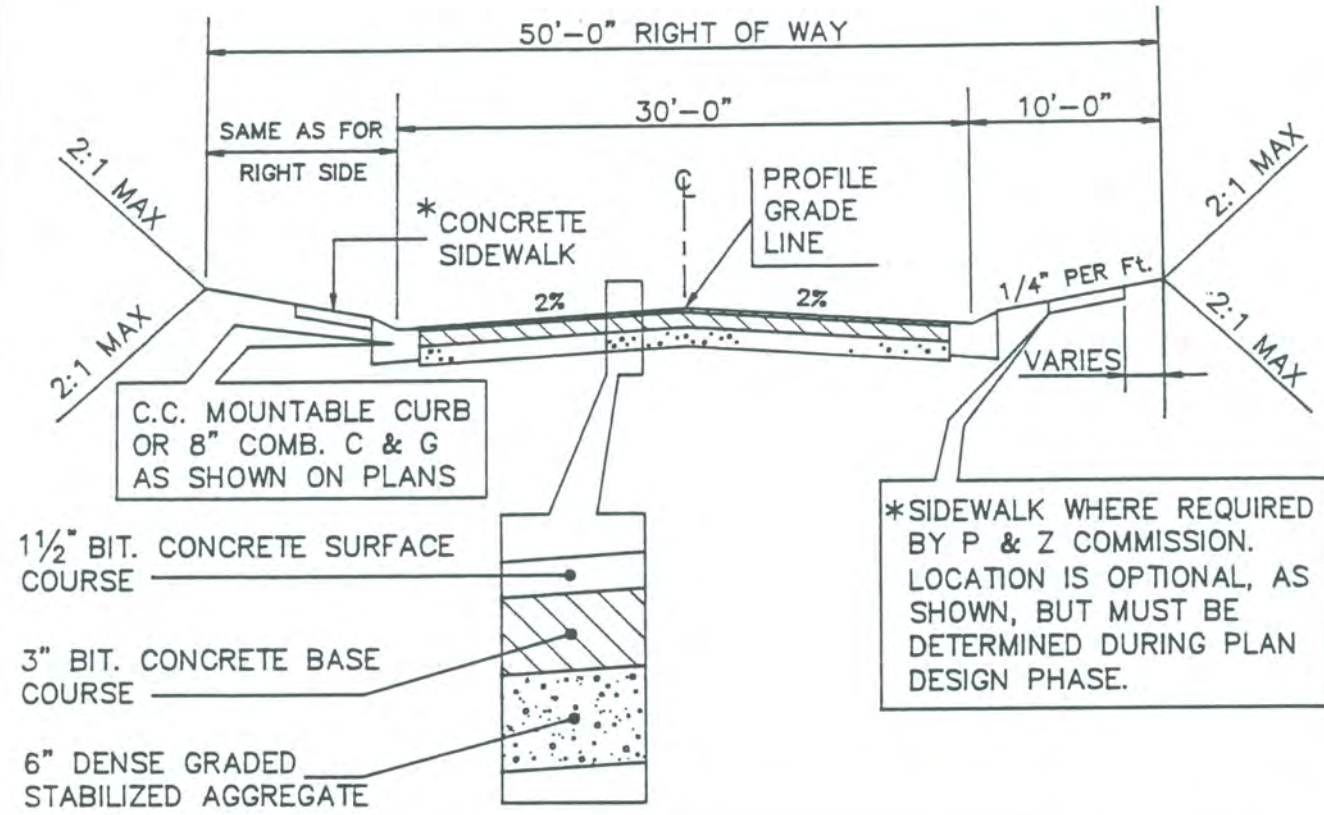

*SIDEWALK WHERE REQUIRED BY P & Z COMMISSION. LOCATION IS OPTIONAL, AS SHOWN, BUT MUST BE DETERMINED DURING PLAN DESIGN PHASE.

ALL DISTURBED AREAS WITHIN RIGHT OF WAY OR EASEMENT LIMITS NEEDED FOR ROADWAY CONSTRUCTION SHALL BE SODDED OR SEEDING AND MULCHED ON 2" OF TOPSOIL.

NOTE:
 THIS TYPICAL SECTION SHALL BE USED IN THE FOLLOWING ZONES WHEN A LOCAL ROAD IS REQUIRED: R-20,000
 R-10,000
 R- 7,500

MAX. ADT = 1000

REVISED	
DATE	BY

CARROLL COUNTY, MARYLAND
 DEPARTMENT OF PUBLIC WORKS

[Signature] 4-12-94
 DIRECTOR DATE

RESIDENTIAL STREET
 30' CLOSED SECTION

PLATE
 19

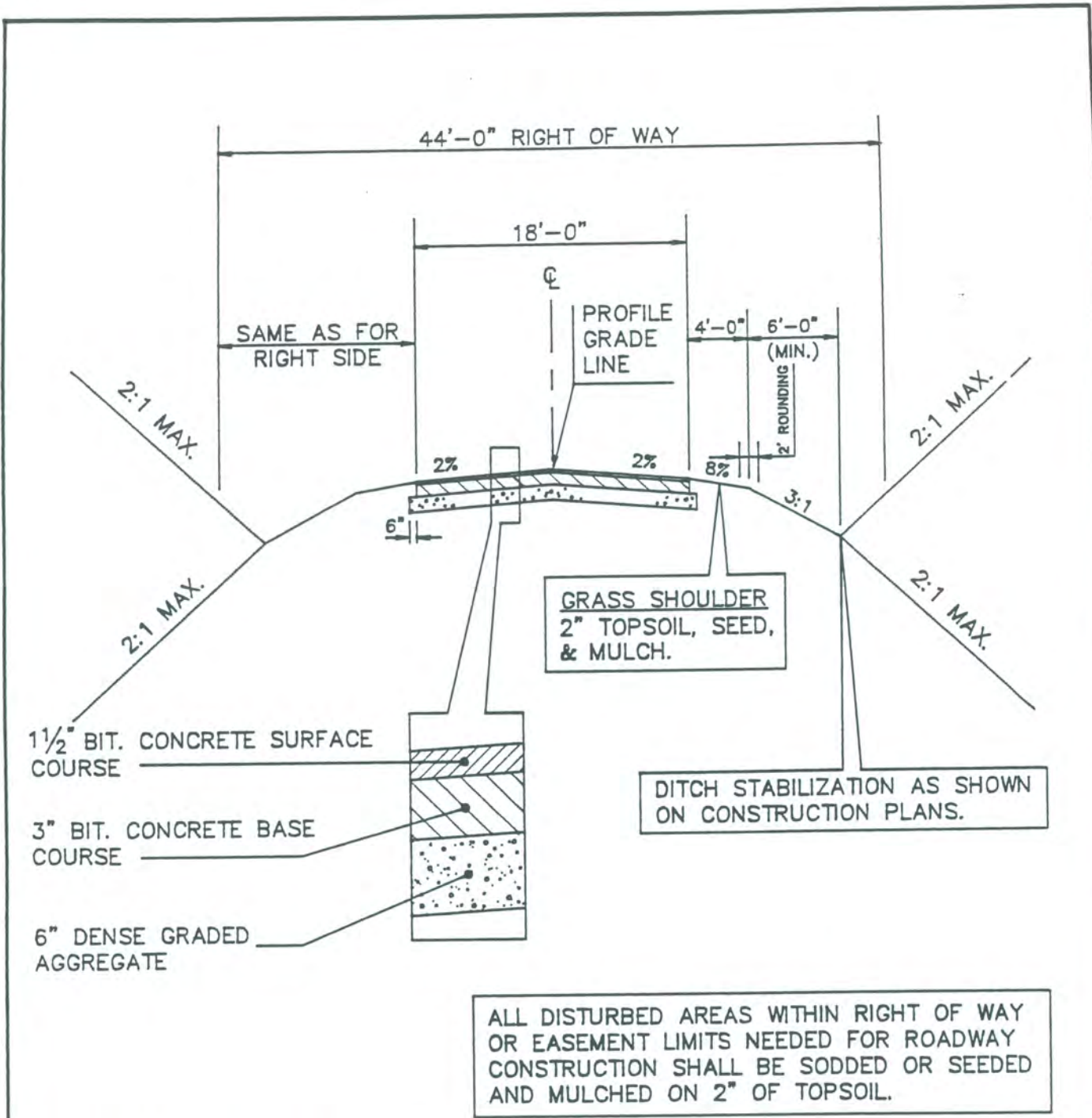

NOTE:

THIS TYPICAL SECTION SHALL BE USED IN THE FOLLOWING ZONES WHEN A LOOP ROAD OR CUL-DE-SAC IS REQUIRED: R-40,000

AGRICULTURAL CONSERVATION

MAX. LENGTH = 1500'
MAX. ADT = 250

REVISED	
DATE	BY

CARROLL COUNTY, MARYLAND
DEPARTMENT OF PUBLIC WORKS

[Signature] 4-12-94
DIRECTOR DATE

LOOP ROAD AND
CUL-DE-SAC ROAD
18' OPEN SECTION

PLATE
20

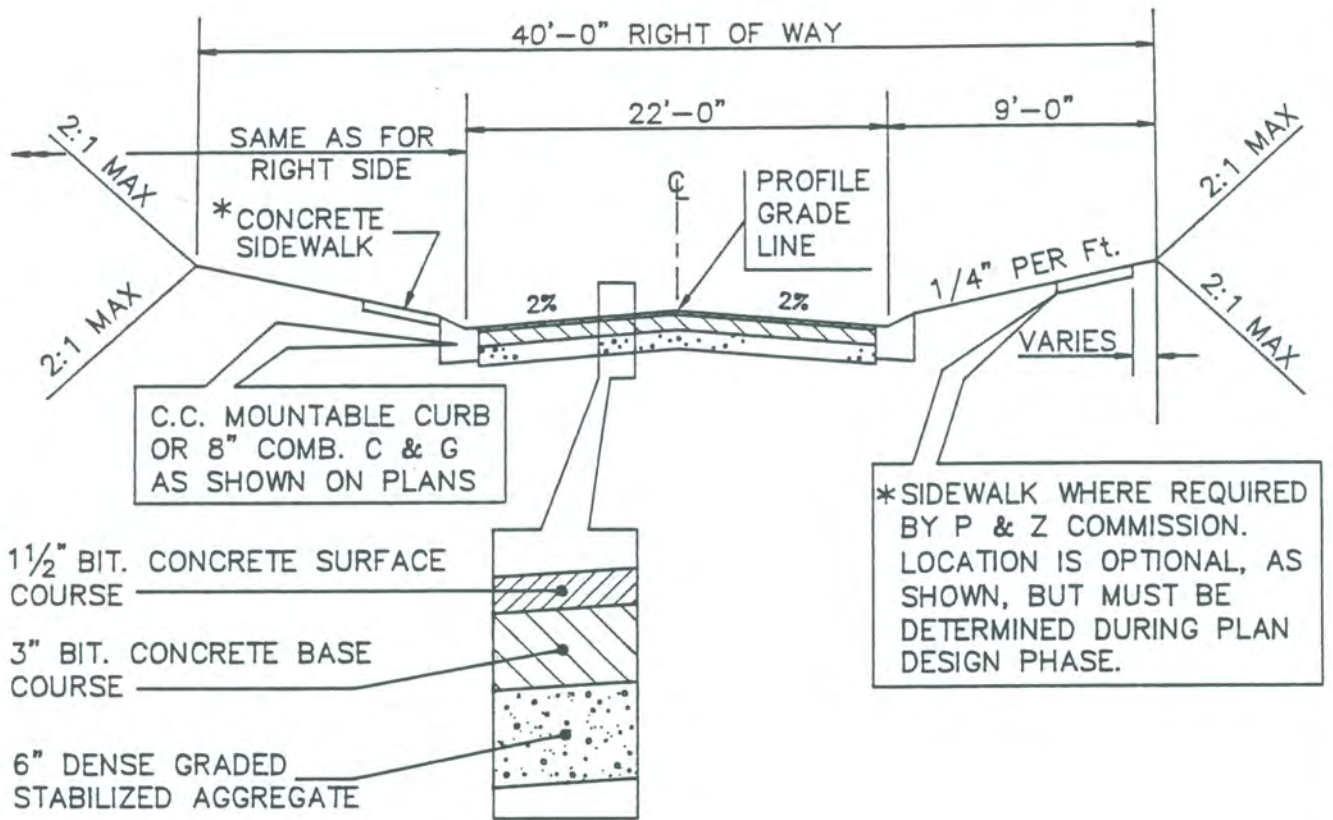

ALL DISTURBED AREAS WITHIN RIGHT OF WAY OR EASEMENT LIMITS NEEDED FOR ROADWAY CONSTRUCTION SHALL BE SODDED OR SEEDED AND MULCHED ON 2" OF TOPSOIL.

NOTE:

THIS TYPICAL SECTION SHALL BE USED IN THE FOLLOWING ZONES WHEN A LOOP ROAD OR CUL-DE-SAC IS REQUIRED: R-20,000
R-10,000
R- 7,500

MAX. LENGTH = 1500'
MAX. ADT = 250

REVISED	
DATE	BY

CARROLL COUNTY, MARYLAND
DEPARTMENT OF PUBLIC WORKS

Kent Kinkaid 4-12-94
DIRECTOR DATE

LOOP ROAD AND
CUL-DE-SAC ROAD
22' CLOSED SECTION

PLATE

21

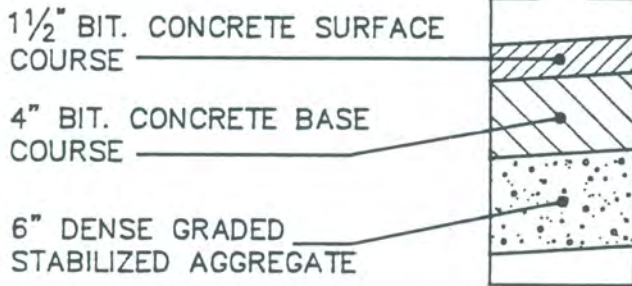
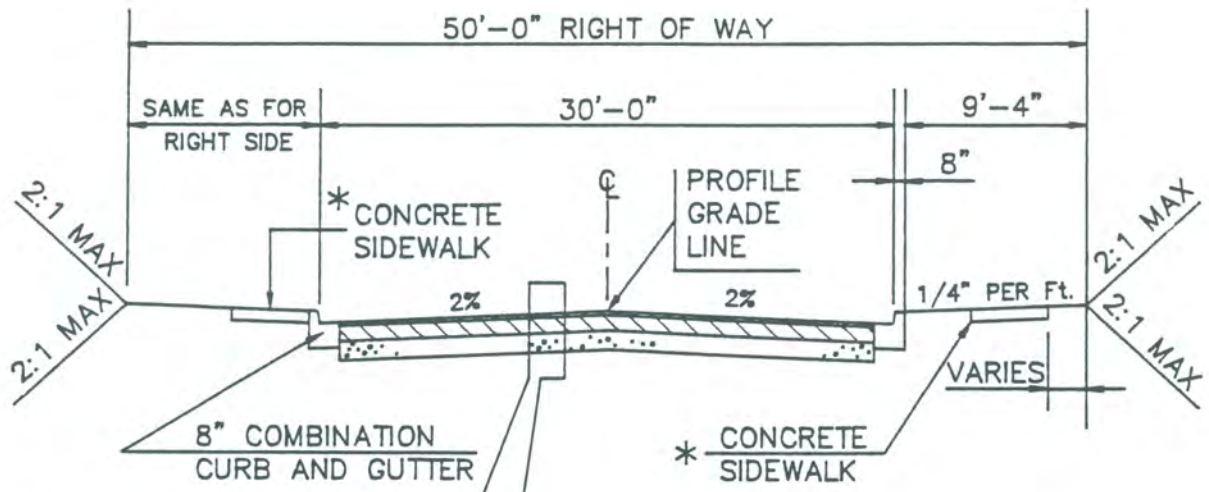

* CONCRETE SIDEWALKS SHALL BE CONSTRUCTED WHEN REQUIRED BY C.C. P & Z COMMISSION. LOCATION IS OPTIONAL, AS SHOWN, BUT MUST BE DETERMINED DURING PLAN DESIGN PHASE.

ALL DISTURBED AREAS WITHIN RIGHT OF WAY OR EASEMENT LIMITS NEEDED FOR ROADWAY CONSTRUCTION SHALL BE SODDED OR SEEDD AND MULCHED ON 2" OF TOPSOIL.

REVISED	
DATE	BY

CARROLL COUNTY, MARYLAND
DEPARTMENT OF PUBLIC WORKS
[Signature] 4-12-94
DIRECTOR DATE

COMMERCIAL - INDUSTRIAL
ROAD

PLATE
22

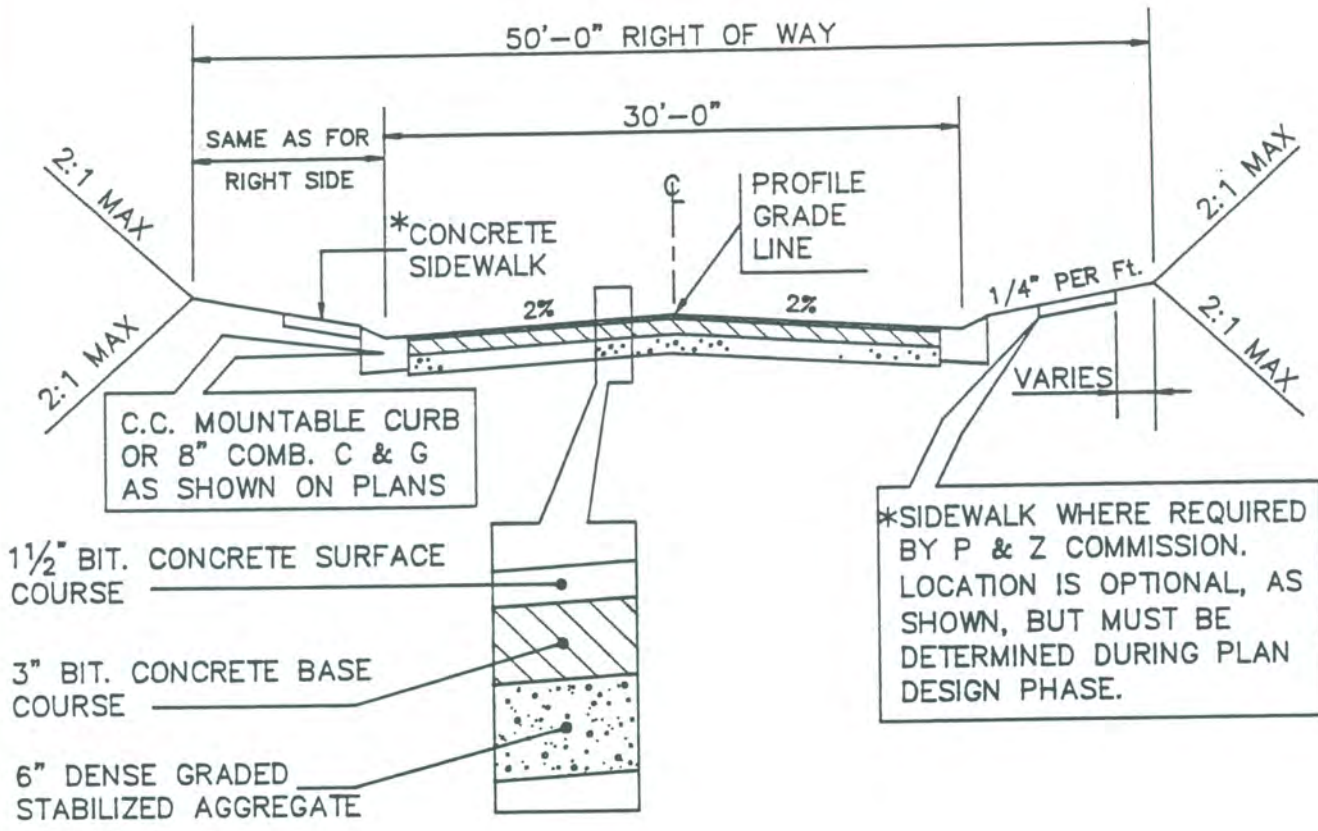

ALL DISTURBED AREAS WITHIN RIGHT OF WAY OR EASEMENT LIMITS NEEDED FOR ROADWAY CONSTRUCTION SHALL BE SODDED OR SEEDS AND MULCHED ON 2" OF TOPSOIL.

MAX. ADT = 1000

REVISED	
DATE	BY

CARROLL COUNTY, MARYLAND
 DEPARTMENT OF PUBLIC WORKS

[Signature] 4-12-94
 DIRECTOR DATE

URBAN LOCAL ROAD
 30' CLOSED SECTION

PLATE
 23

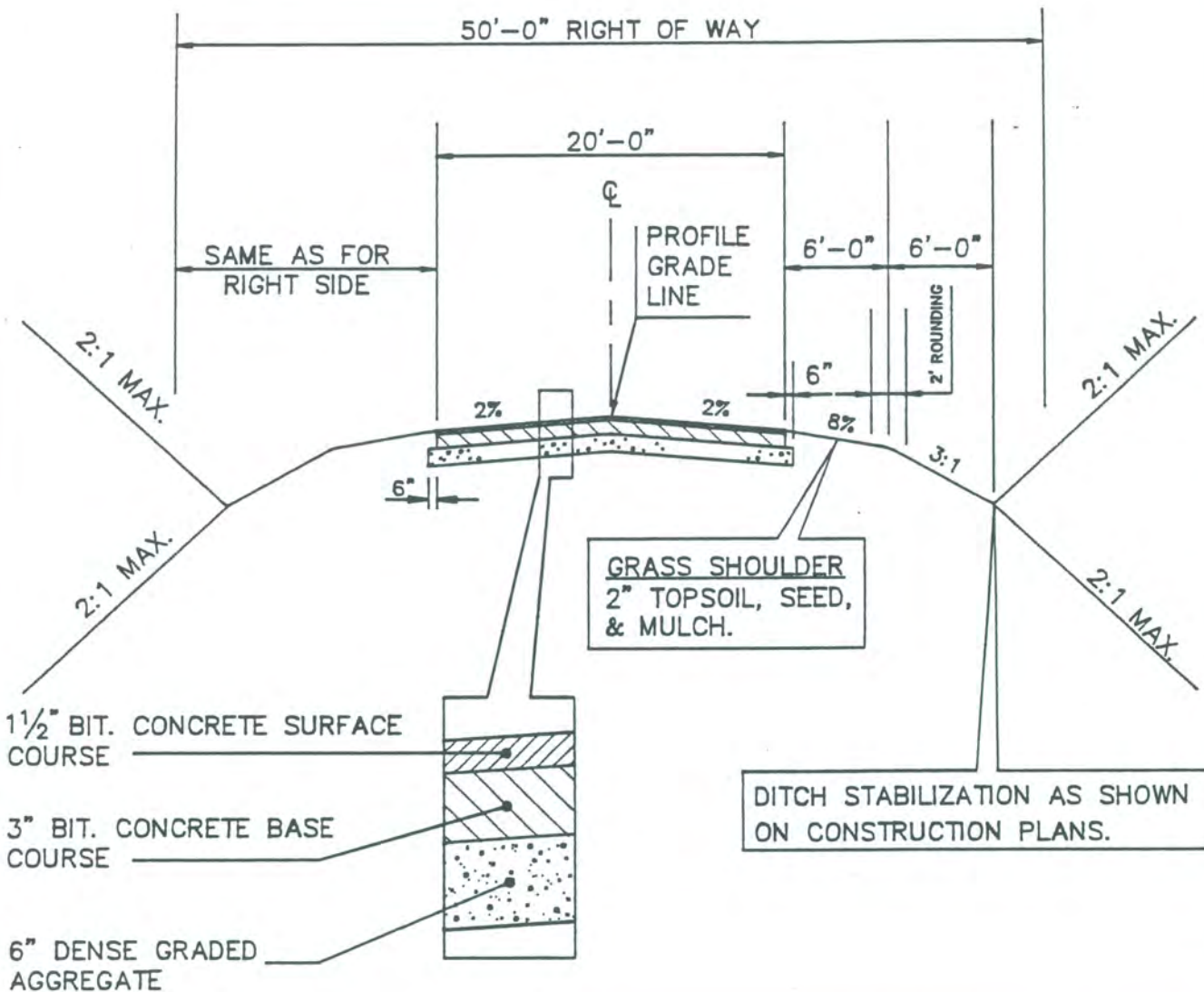

MAX. ADT = 1000

REVISED	
DATE	BY

CARROLL COUNTY, MARYLAND
DEPARTMENT OF PUBLIC WORKS

K. D. King 4-12-94
DIRECTOR DATE

RURAL LOCAL ROAD
20' OPEN SECTION

PLATE
24

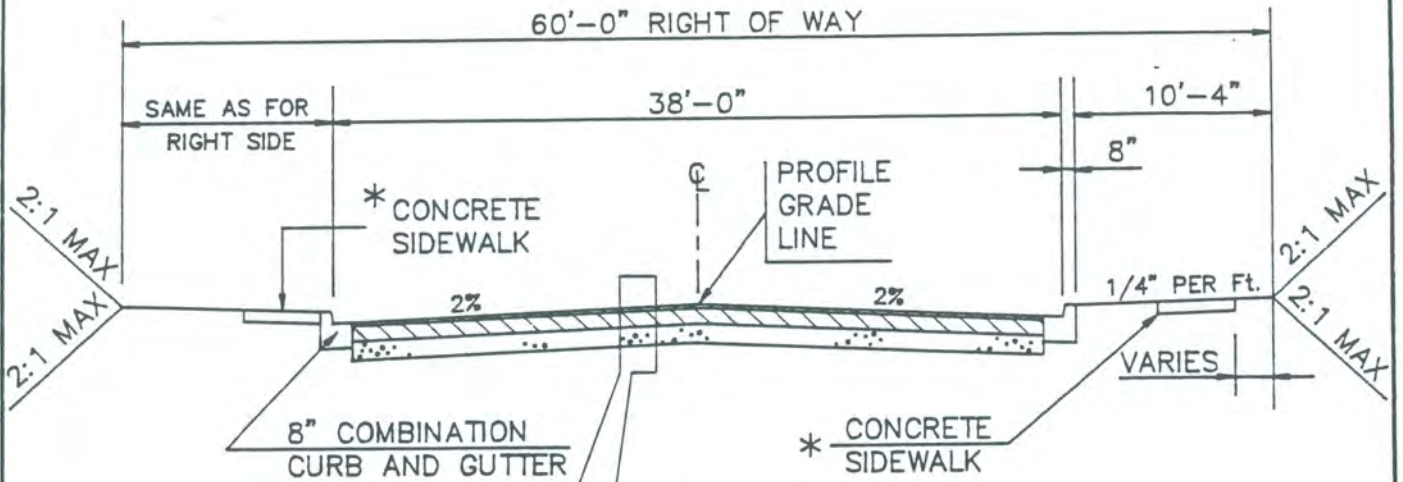

1 1/2" BIT. CONCRETE SURFACE COURSE

4" BIT. CONCRETE BASE COURSE

6" DENSE GRADED STABILIZED AGGREGATE



* CONCRETE SIDEWALKS SHALL BE CONSTRUCTED WHEN REQUIRED BY C.C. P & Z COMMISSION. LOCATION IS OPTIONAL, AS SHOWN, BUT MUST BE DETERMINED DURING PLAN DESIGN PHASE.

ALL DISTURBED AREAS WITHIN RIGHT OF WAY OR EASEMENT LIMITS NEEDED FOR ROADWAY CONSTRUCTION SHALL BE SODDED OR SEEDD AND MULCHED ON 2" OF TOPSOIL.

OVER 1000 ADT

REVISED	
DATE	BY

CARROLL COUNTY, MARYLAND
DEPARTMENT OF PUBLIC WORKS

[Signature] 4-12-94
DIRECTOR DATE

URBAN COLLECTOR ROAD
38' CLOSED SECTION

PLATE
25

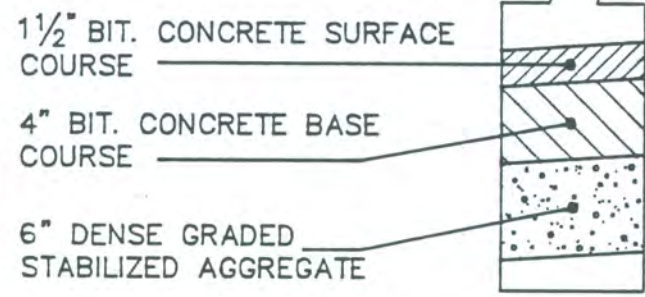
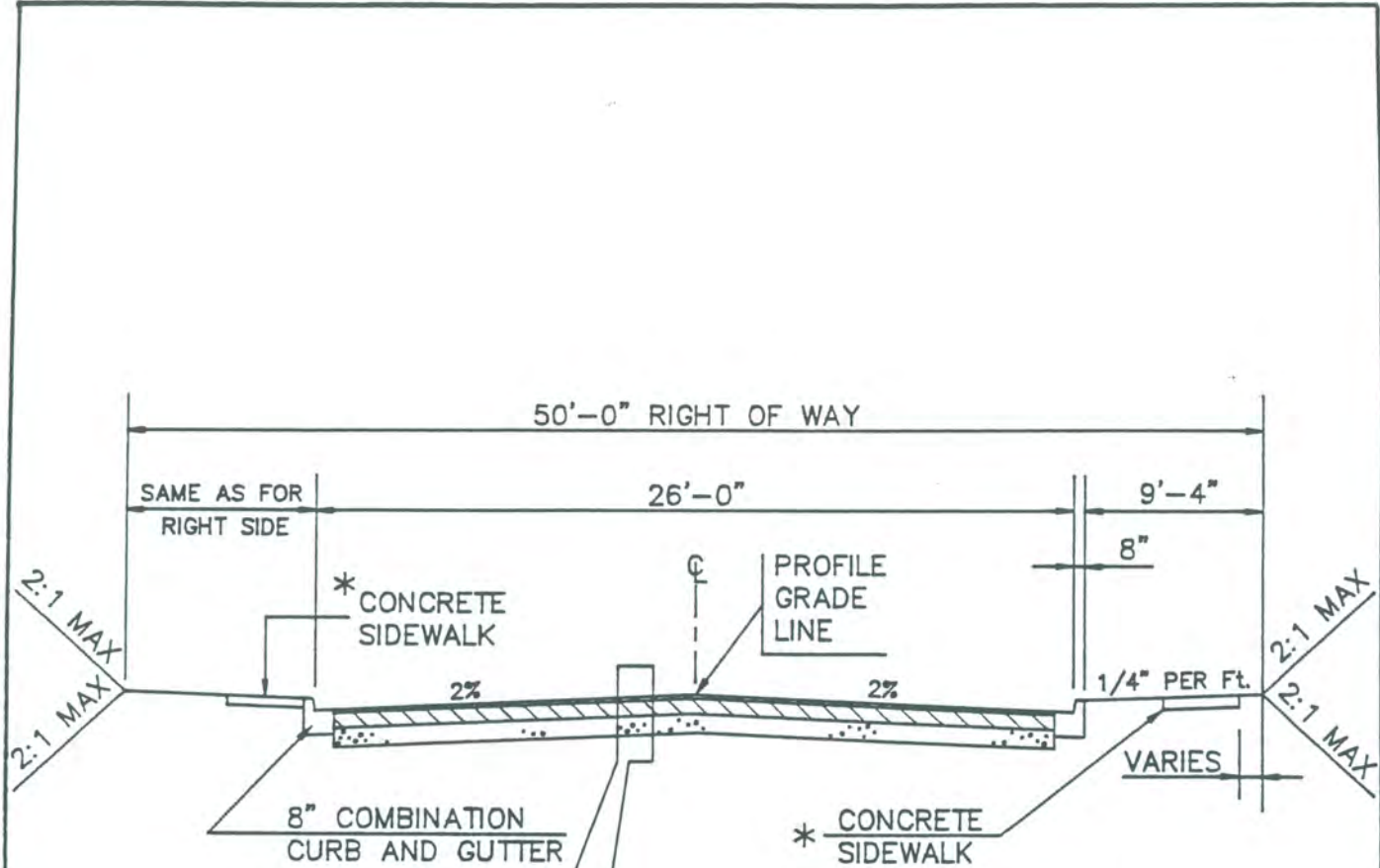

* CONCRETE SIDEWALKS SHALL BE CONSTRUCTED WHEN REQUIRED BY C.C.P & Z COMMISSION. LOCATION IS OPTIONAL, AS SHOWN, BUT MUST BE DETERMINED DURING PLAN DESIGN PHASE.

ALL DISTURBED AREAS WITHIN RIGHT OF WAY OR EASEMENT LIMITS NEEDED FOR ROADWAY CONSTRUCTION SHALL BE SODDED OR SEEDED AND MULCHED ON 2" OF TOPSOIL.

OVER 1000 ADT

REVISED	
DATE	BY

CARROLL COUNTY, MARYLAND
DEPARTMENT OF PUBLIC WORKS
[Signature] 4-12-94
DIRECTOR DATE

URBAN COLLECTOR ROAD
26' CLOSED SECTION

PLATE
25-A

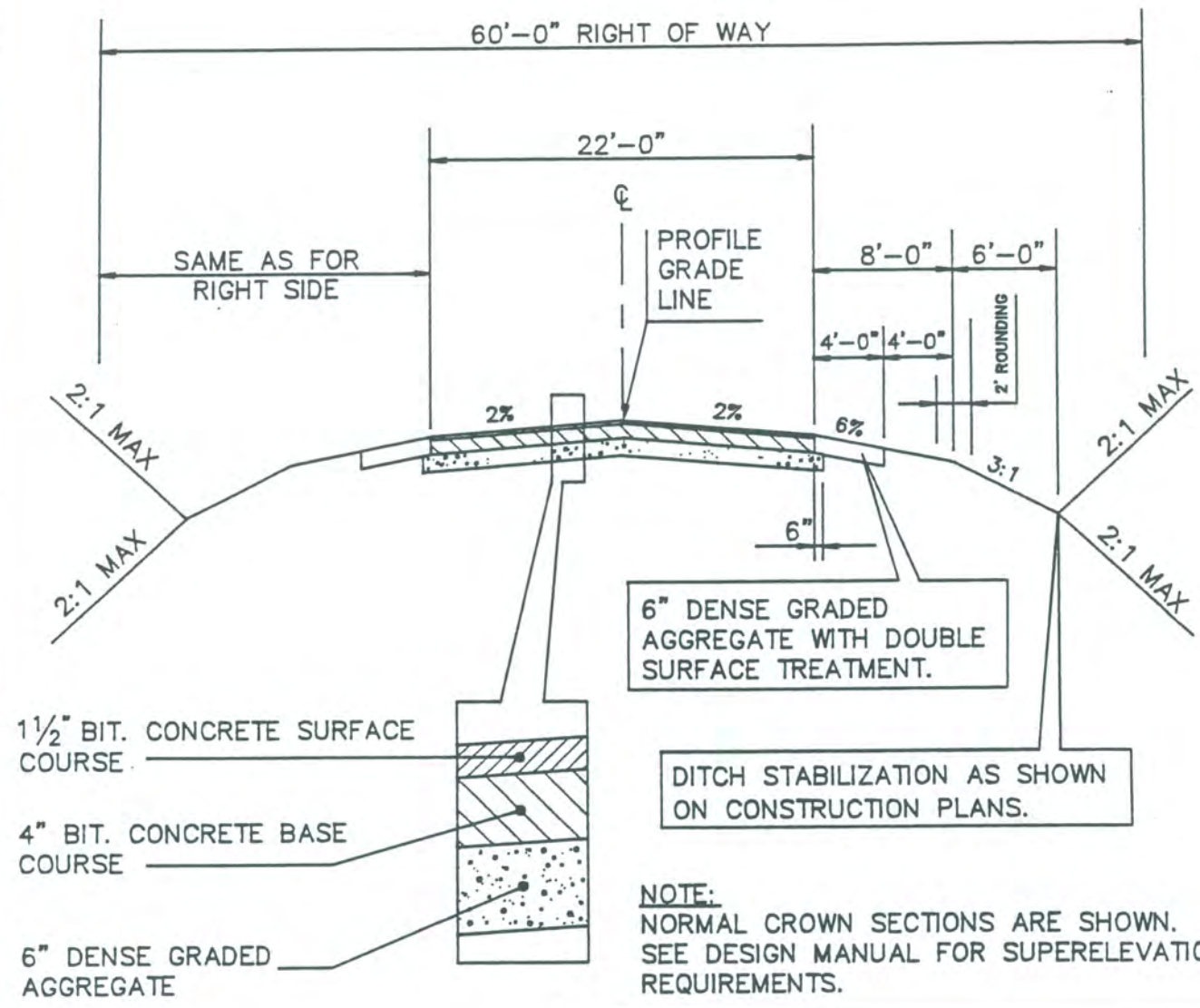

ALL DISTURBED AREAS WITHIN RIGHT OF WAY OR EASEMENT LIMITS NEEDED FOR ROADWAY CONSTRUCTION SHALL BE SODDED OR SEEDDED AND MULCHED ON 2" OF TOPSOIL.

OVER 1000 ADT

REVISED	
DATE	BY

CARROLL COUNTY, MARYLAND
DEPARTMENT OF PUBLIC WORKS

Handwritten Signature 4-12-94
DIRECTOR DATE

RURAL COLLECTOR ROAD
22' OPEN SECTION

PLATE
26

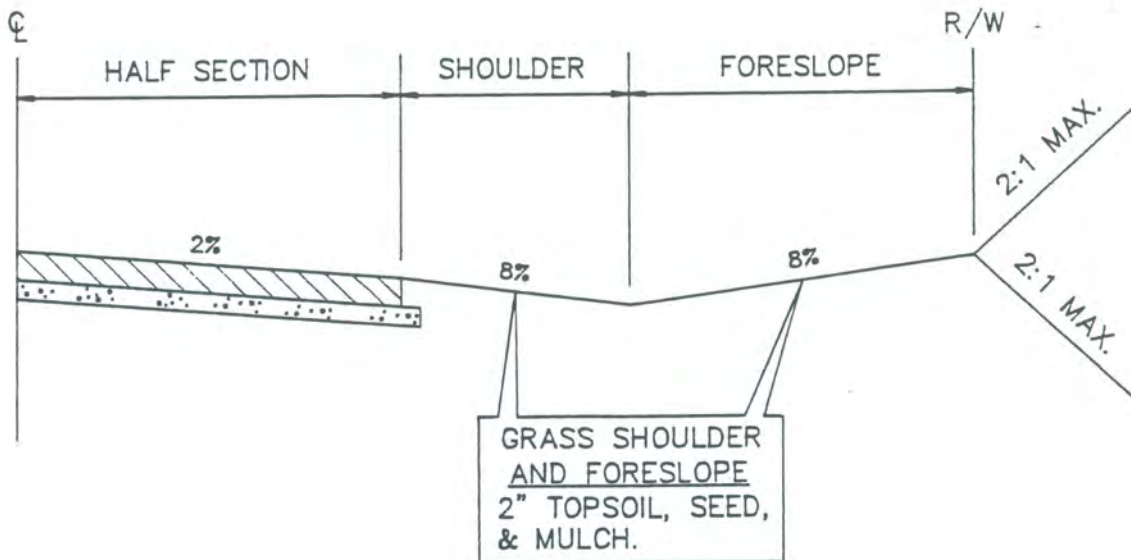

NOTE:

THIS DESIGN WILL ONLY BE ALLOWED WITH PRIOR APPROVAL FROM THE BUREAU OF ENGINEERING. SEE 2.7.5 FOR INFORMATION REGARDING IT'S USAGE.

REVISED	
DATE	BY

CARROLL COUNTY, MARYLAND
DEPARTMENT OF PUBLIC WORKS

[Signature] 4-12-94
DIRECTOR DATE

MODIFIED SWALE DESIGN

PLATE

27

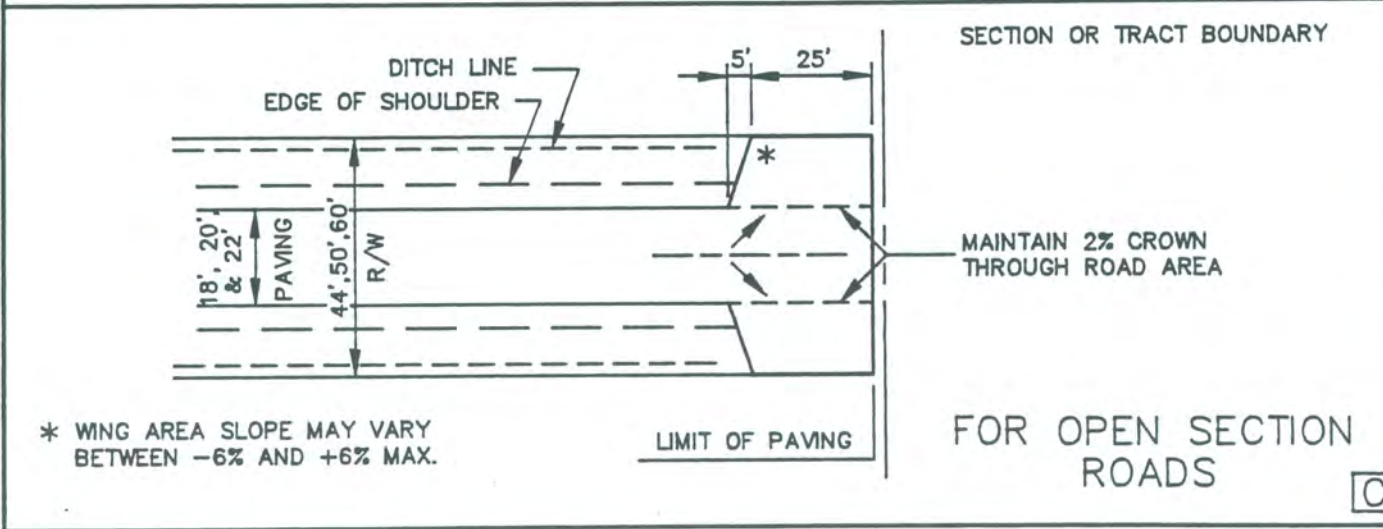
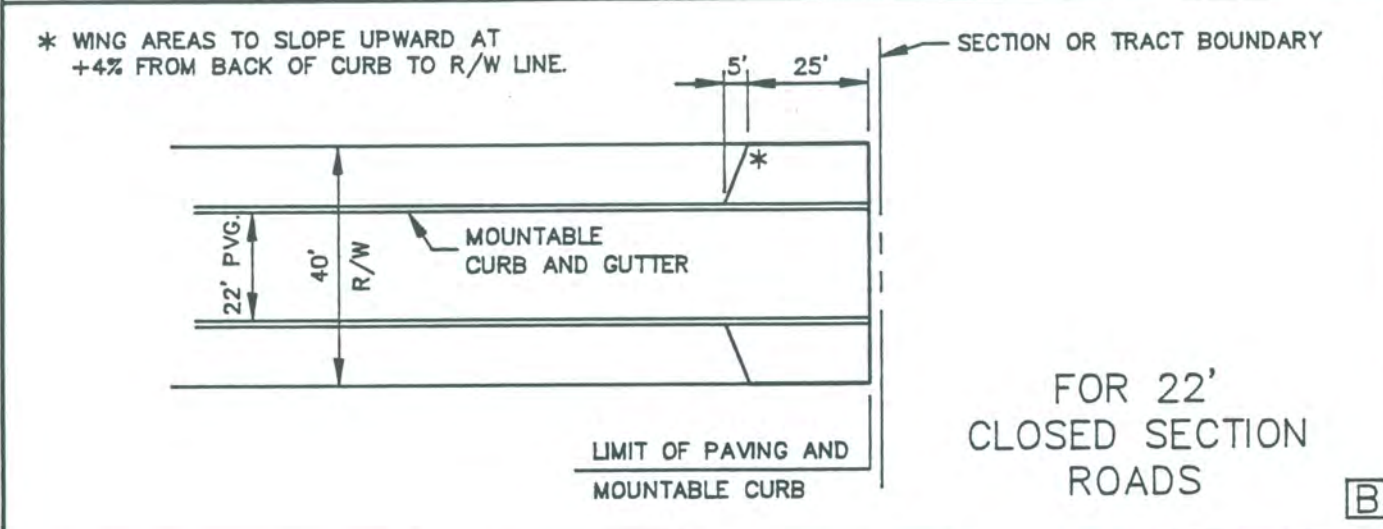
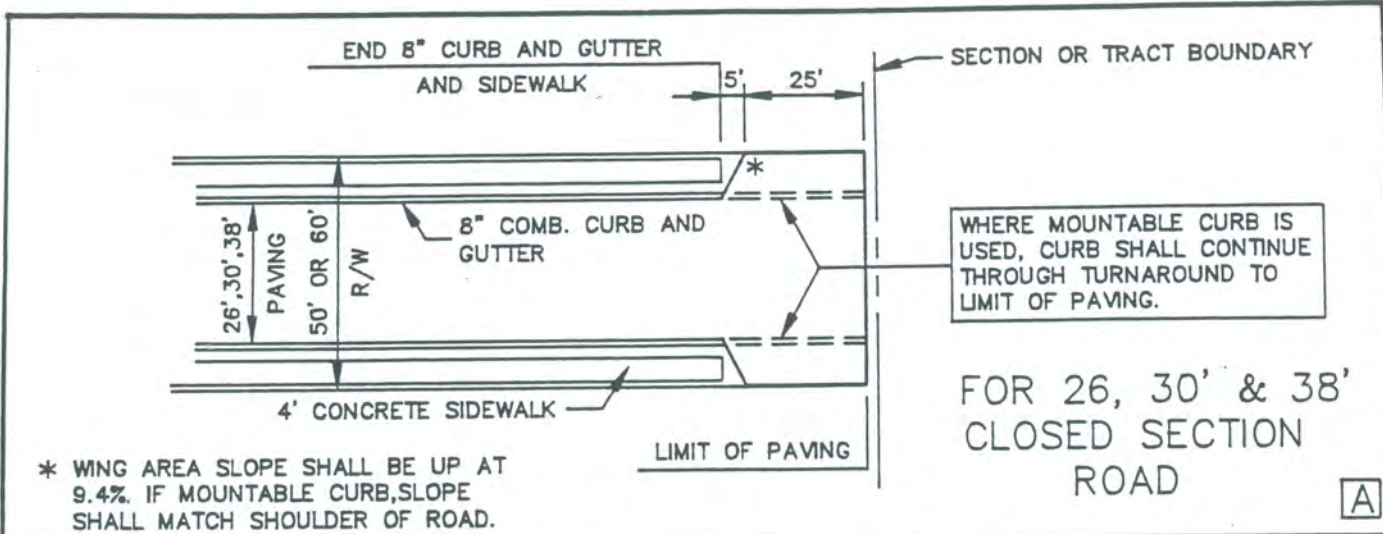

NOTE:
DRIVEWAY APRONS MAY NOT BE CONSTRUCTED IN "T" TURNAROUNDS.

REVISED	
DATE	BY

CARROLL COUNTY, MARYLAND
DEPARTMENT OF PUBLIC WORKS

Edward J. ... 4-12-94
DIRECTOR DATE

TEMPORARY
"T" TURNAROUNDS

PLATE
28

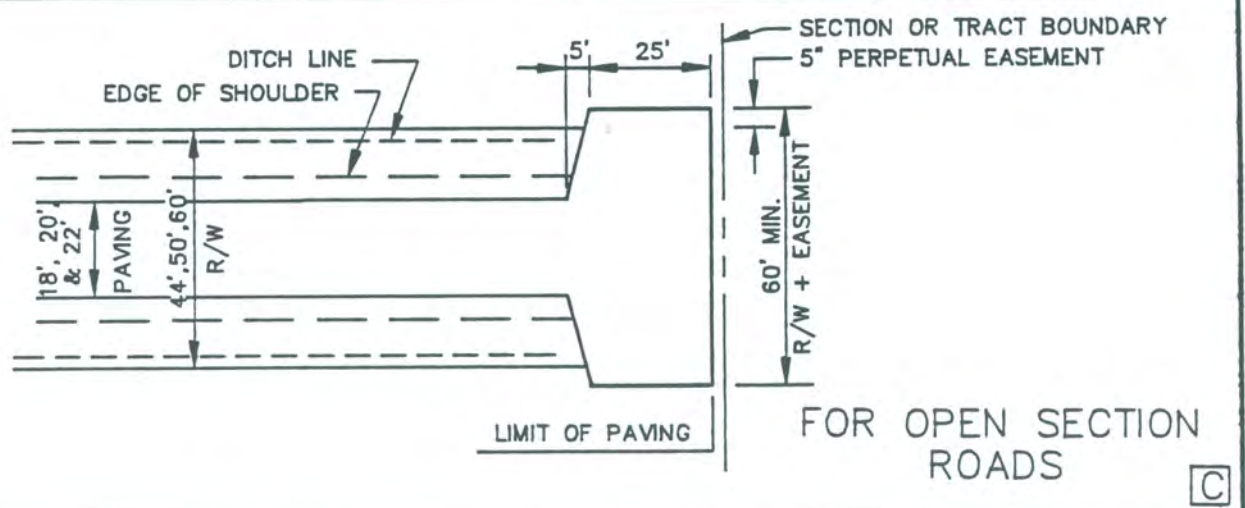
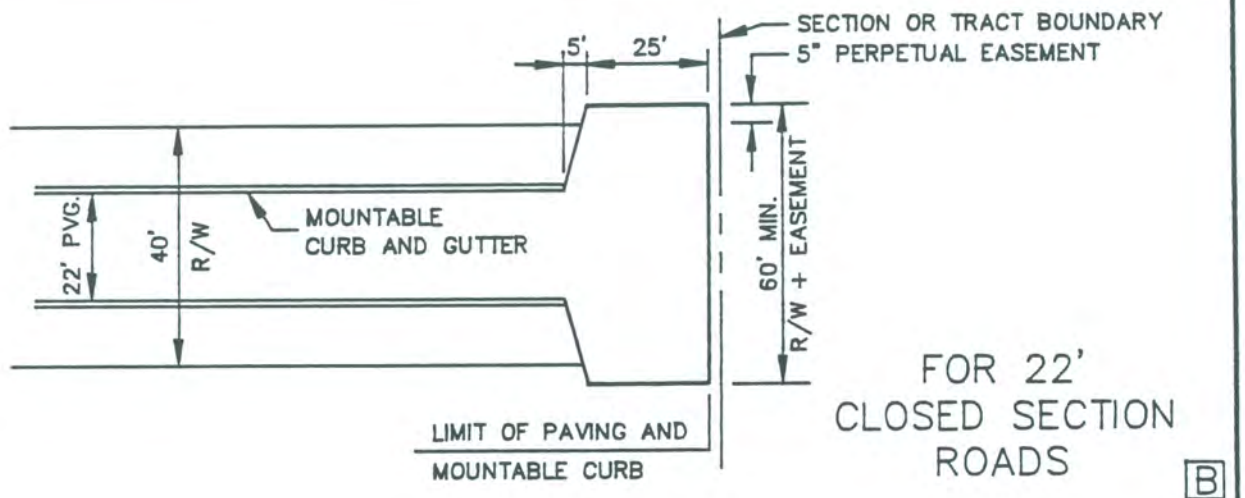
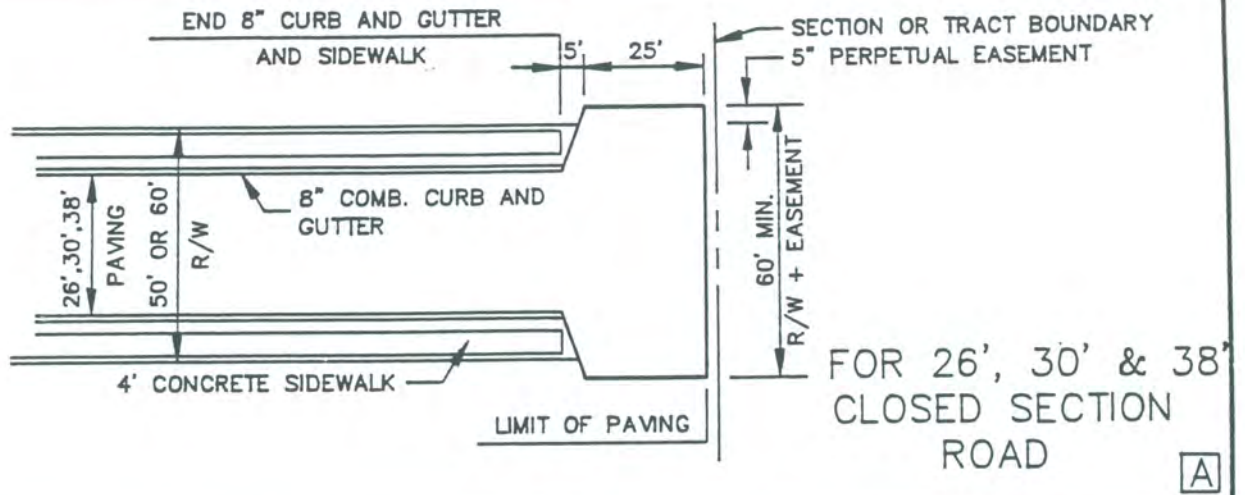

NOTE:
DRIVEWAY APRONS MAY NOT BE CONSTRUCTED IN "T" TURNAROUNDS.

REVISED	
DATE	BY

CARROLL COUNTY, MARYLAND
DEPARTMENT OF PUBLIC WORKS
Edward [Signature] 4-12-94
DIRECTOR DATE

PERMANENT
"T" TURNAROUNDS

PLATE
29

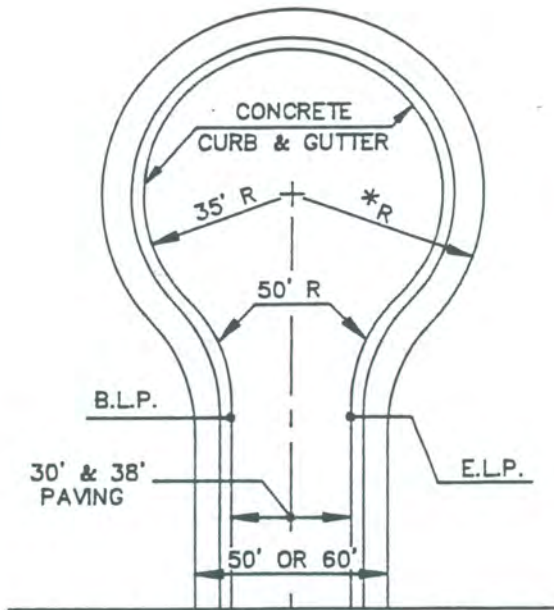

FOR 30' AND 38'
CLOSED SECTION ROAD

A

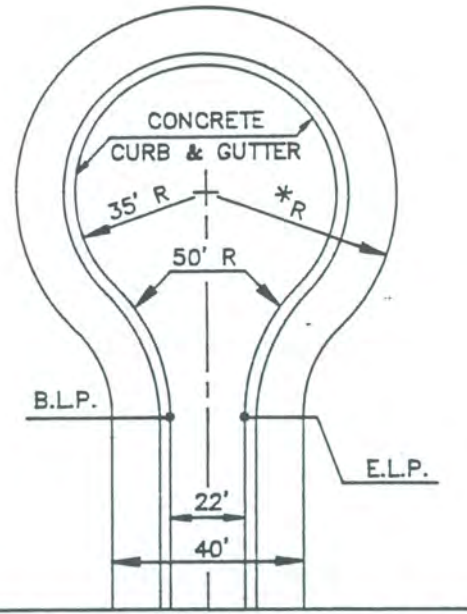

FOR 22' CLOSED SECTION ROAD

B

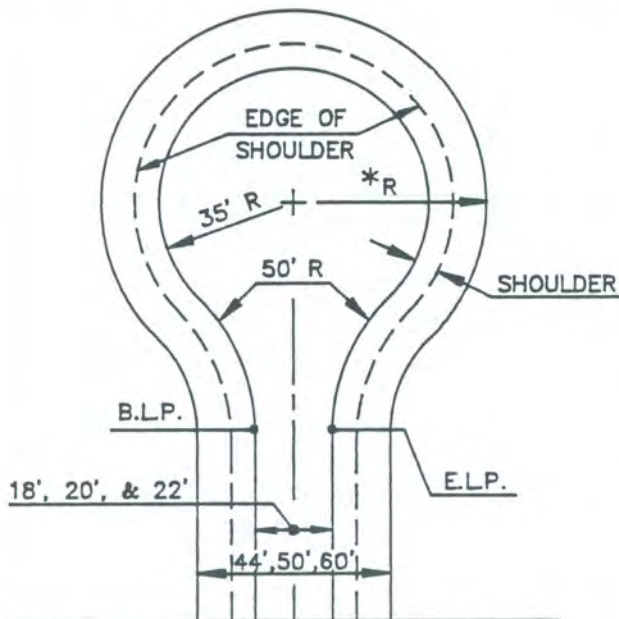

FOR OPEN SECTION ROADS

C

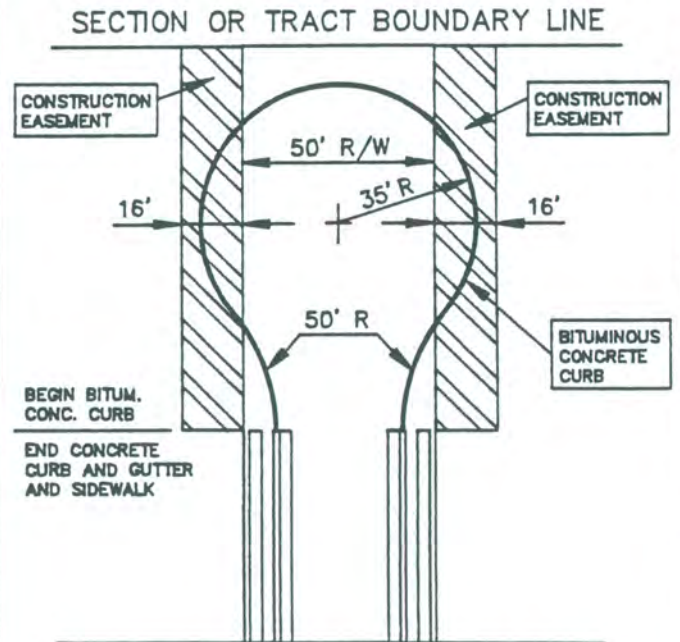

FOR CLOSED SECTION ROADS
TEMPORARY CUL-DE-SAC

D

FOR OPEN SECTION ROADS TEMP. C.D.S. SHALL BE SAME AS FOR PERMANENT. SEE [C] ABOVE.

NOTE:

B.L.P.= BEGIN LINEAR PROFILE
E.L.P.= END LINEAR PROFILE

* IN OPTIONS A, B & C PAVING SHALL BE CONCENTRIC WITH RIGHT OF WAY

REVISED	
DATE	BY

CARROLL COUNTY, MARYLAND
DEPARTMENT OF PUBLIC WORKS

Handwritten signature 4-12-94
DIRECTOR DATE

CUL-DE-SAC DETAILS
STRAIGHT

PLATE

30

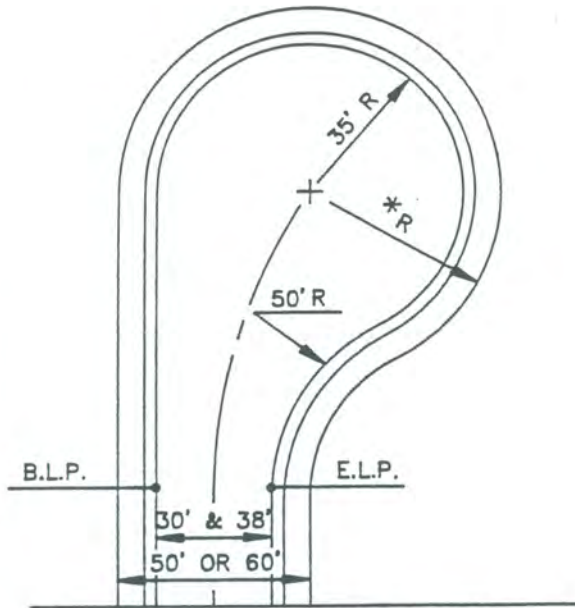

FOR 30' AND 38' CLOSED SECTION ROAD

A

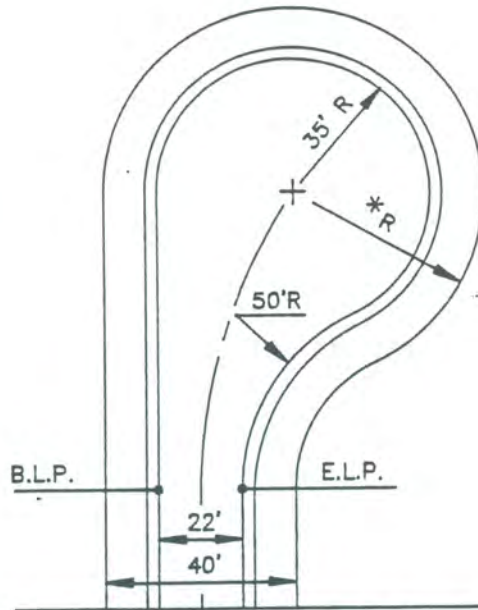

FOR 22' CLOSED SECTION ROAD

B

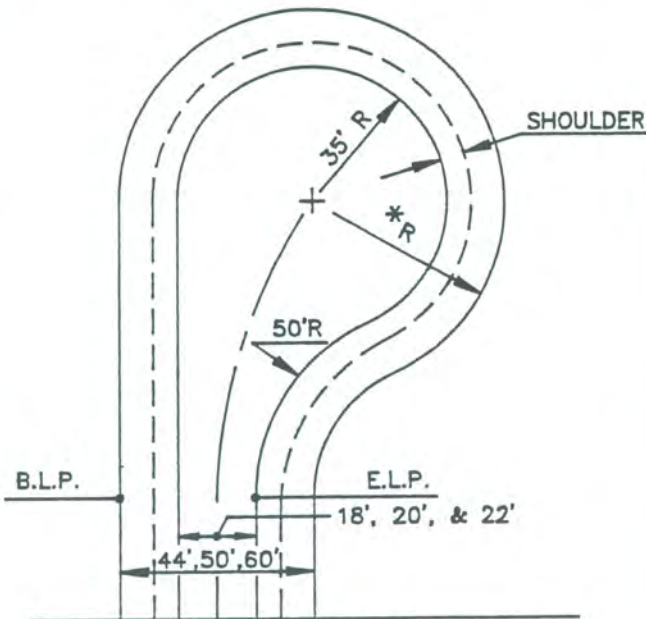

FOR OPEN SECTION ROADS

C

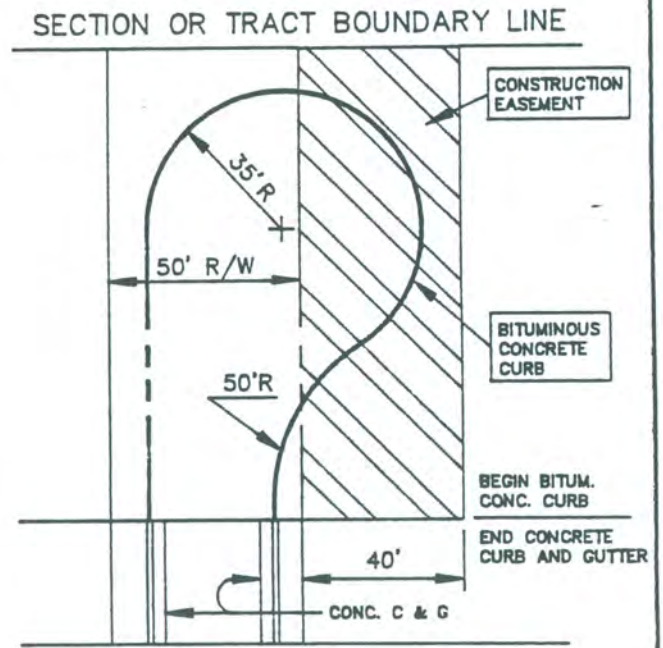

FOR CLOSED SECTION ROADS TEMPORARY CUL-DE-SAC

D

FOR OPEN SECTION ROADS TEMP. C.D.S. SHALL BE SAME AS FOR PERMANENT. SEE [C] ABOVE.

NOTE:

B.L.P.= BEGIN LINEAR PROFILE
E.L.P.= END LINEAR PROFILE

* IN OPTIONS A, B & C PAVING SHALL BE CONCENTRIC WITH RIGHT OF WAY

REVISED	
DATE	BY

CARROLL COUNTY, MARYLAND
DEPARTMENT OF PUBLIC WORKS

Ed. D. ... 4-12-94
DIRECTOR DATE

CUL-DE-SAC DETAILS
OFFSET

PLATE

31

GRASS OR LANDSCAPED ISLAND

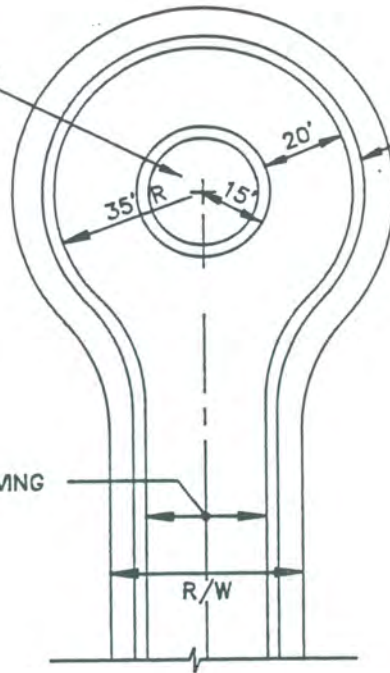

CONCRETE CURB & GUTTER

PAVING

R/W

STRAIGHT

GRASS OR LANDSCAPED ISLAND

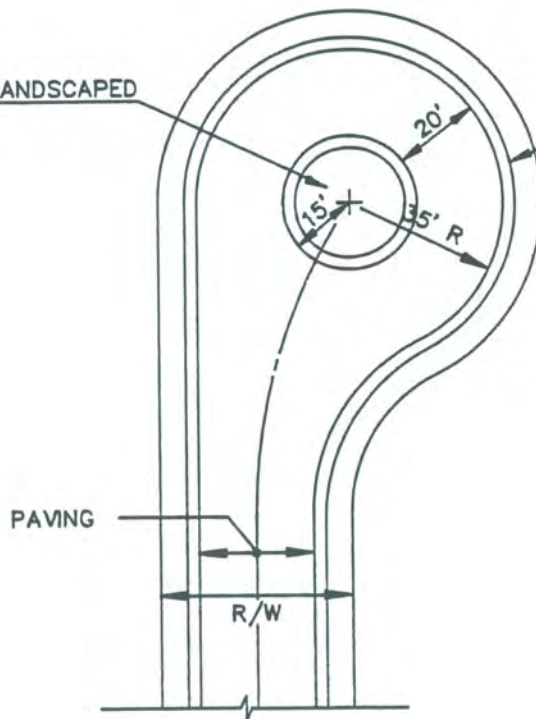

CONCRETE CURB & GUTTER

PAVING

R/W

OFFSET

NOTE:

1. ISLANDS TO BE MAINTAINED BY H.O.A.
2. SEE PLATES 30 & 31 FOR CUL-DE-SAC CONSTRUCTION DETAILS.

REVISED	
DATE	BY

CARROLL COUNTY, MARYLAND
DEPARTMENT OF PUBLIC WORKS

Keith D. ... 4-12-94
DIRECTOR DATE

STRAIGHT AND OFFSET
CUL-DE-SACS WITH ISLANDS

PLATE

32

TWO WAY TRAFFIC

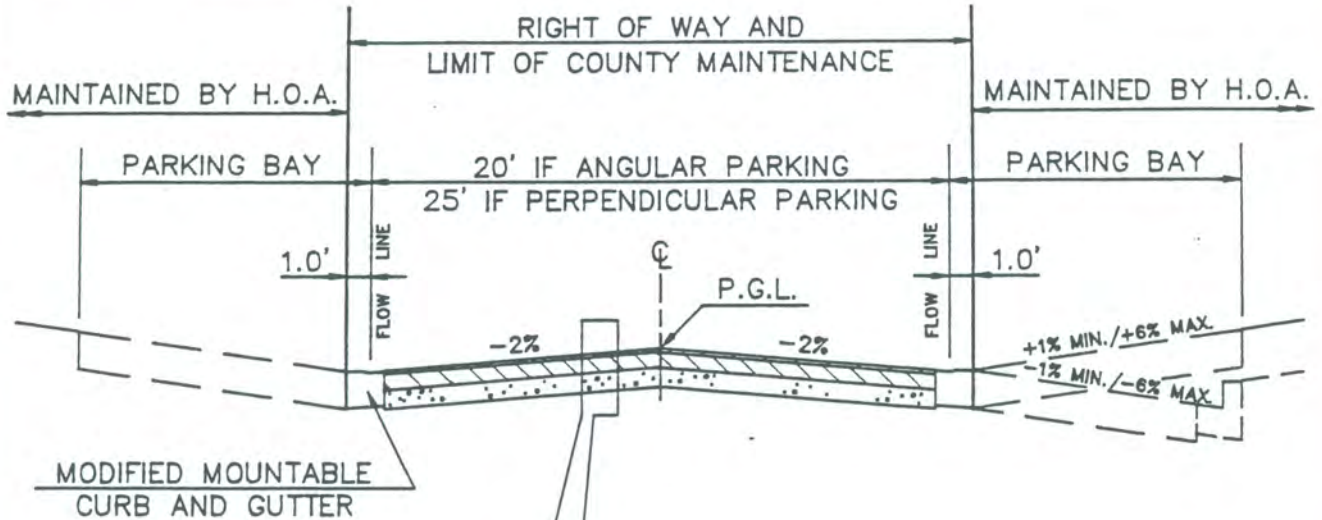

1 1/2" BIT. CONCRETE SURFACE COURSE BAND S.C.

3" BIT. CONCRETE BASE COURSE BAND B.C.

6" DENSE GRADED STABILIZED AGGREGATE

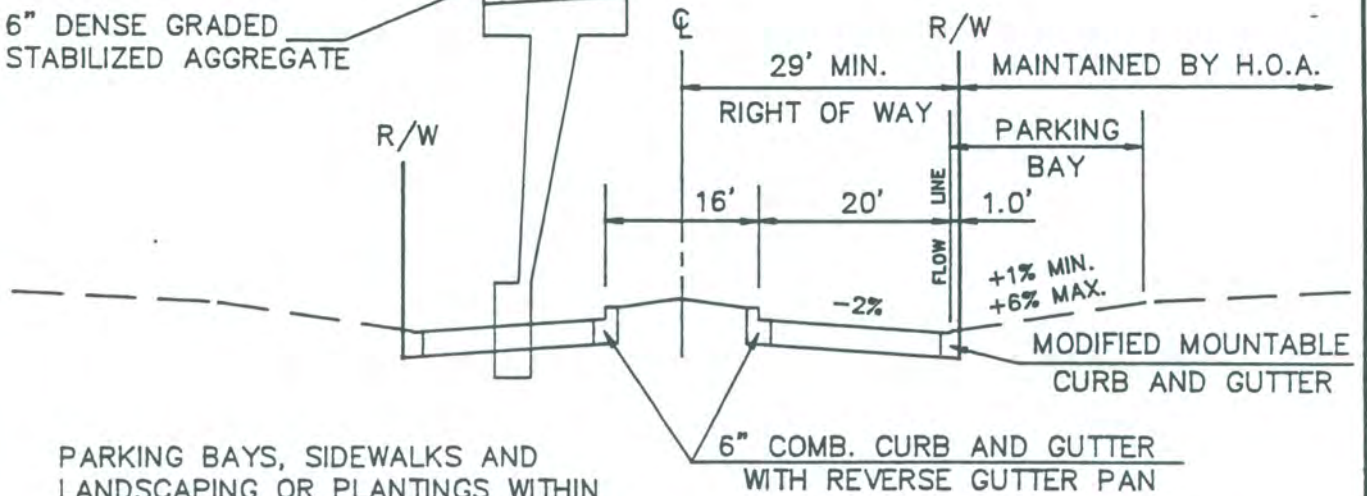

PARKING BAYS, SIDEWALKS AND LANDSCAPING OR PLANTINGS WITHIN ISLANDS TO BE MAINTAINED BY H.O.A.

ONE WAY TRAFFIC WITH GRASS ISLAND

REVISED	
DATE	BY

CARROLL COUNTY, MARYLAND
DEPARTMENT OF PUBLIC WORKS

[Signature] 4-12-94
DIRECTOR DATE

MULTI-FAMILY DEVELOPMENT
TYPICAL SECTIONS FOR ROADS

PLATE

33

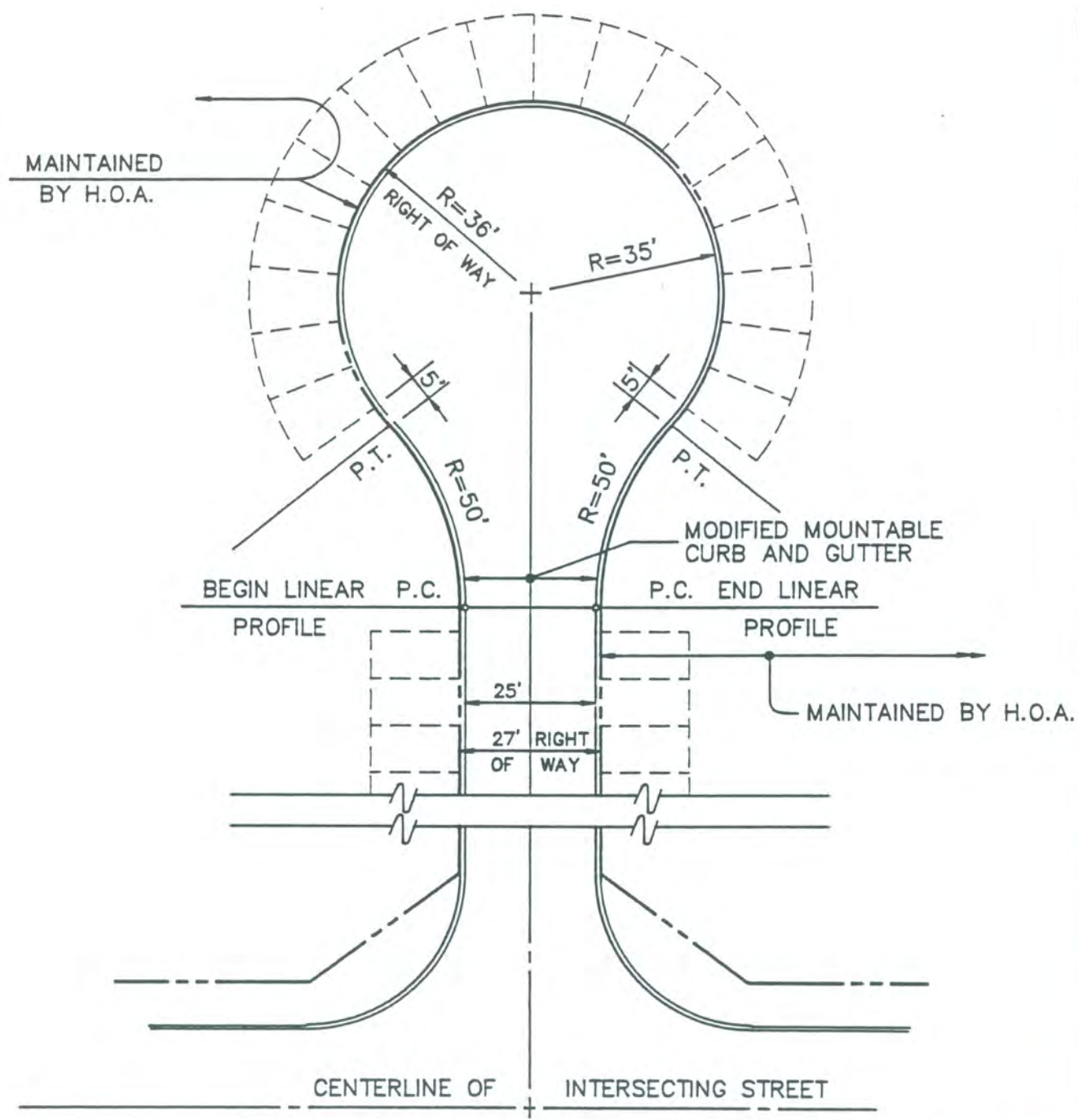

REVISED	
DATE	BY

CARROLL COUNTY, MARYLAND
DEPARTMENT OF PUBLIC WORKS

MULTI-FAMILY DEVELOPMENT

Edward J. ...
DIRECTOR 4-12-94
DATE

SCHEMATIC DESIGN
FOR CUL-DE-SAC

PLATE
34

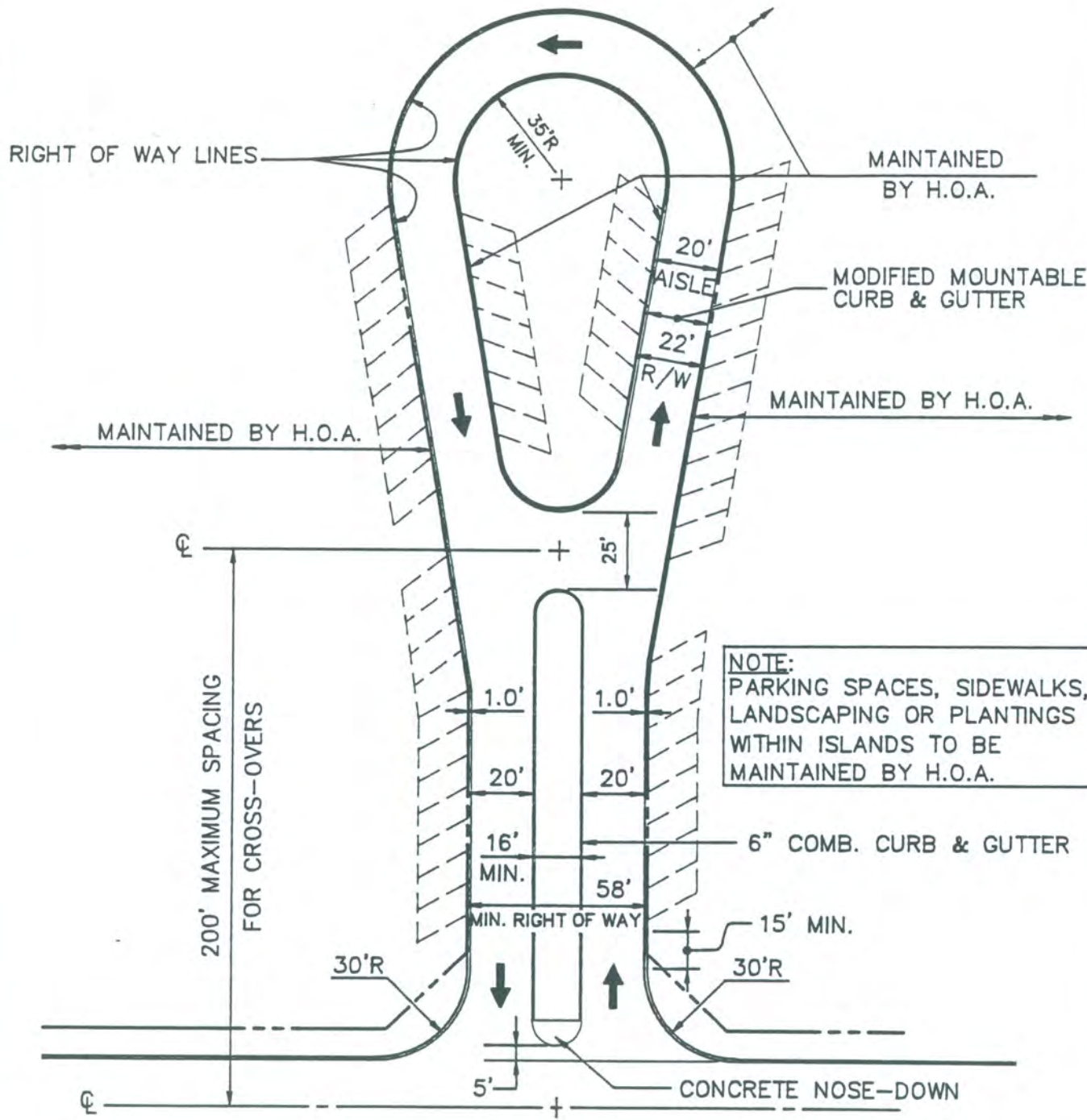

NOTE:
 PARKING SPACES, SIDEWALKS,
 LANDSCAPING OR PLANTINGS
 WITHIN ISLANDS TO BE
 MAINTAINED BY H.O.A.

REVISED	
DATE	BY

CARROLL COUNTY, MARYLAND
 DEPARTMENT OF PUBLIC WORKS
Carroll County 4-12-94
 DIRECTOR DATE

**MULTI-FAMILY DEVELOPMENT
 SCHEMATIC DESIGN
 STANDARDS FOR COURTS**

PLATE
 35

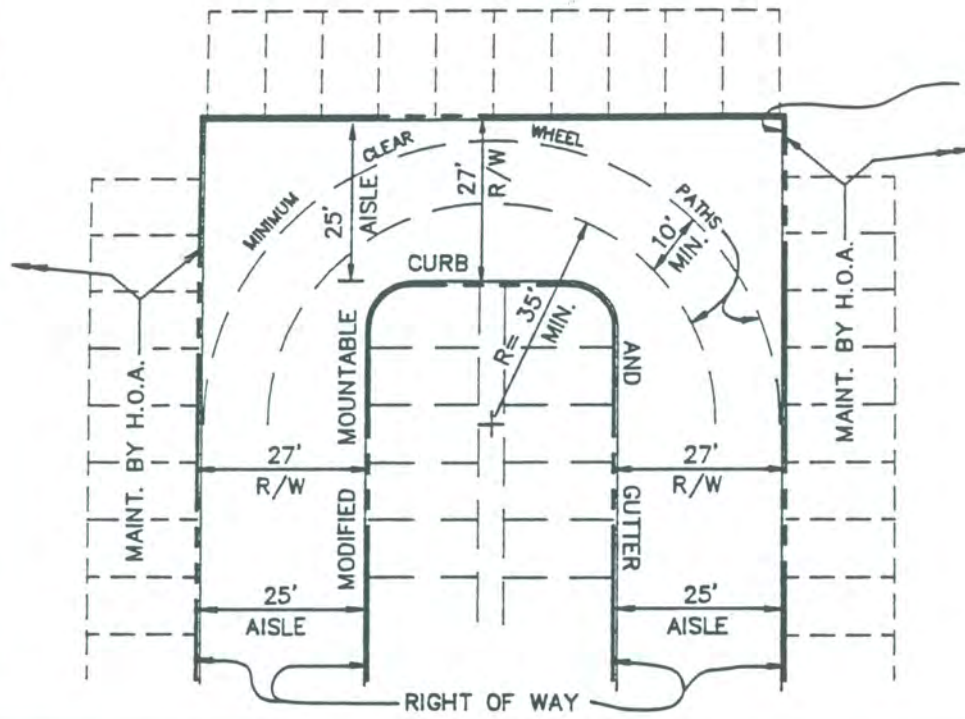

ALL CURB TO BE MODIFIED
MOUNTABLE CURB & GUTTER

**PERPENDICULAR
LAYOUT
FOR TWO WAY TRAFFIC**

**ANGLE PARKING
LAYOUT
FOR ONE WAY TRAFFIC**

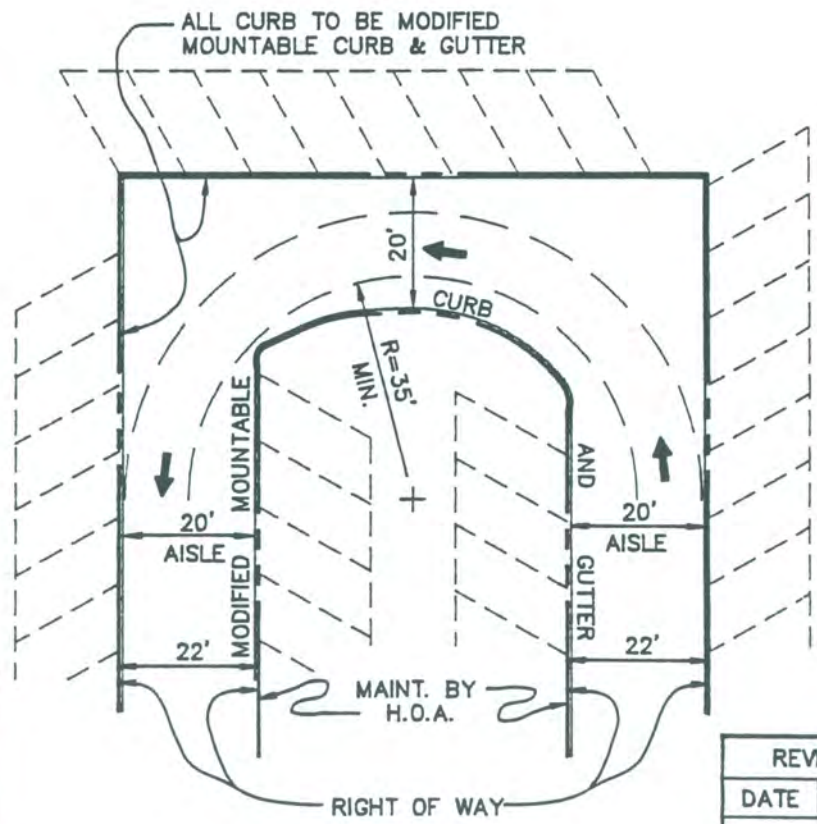

ALL CURB TO BE MODIFIED
MOUNTABLE CURB & GUTTER

NOTE:
CROSS-OVERS MUST BE
PROVIDED AT 200' MAX.
SPACING IN BOTH LAYOUTS.

REVISED	
DATE	BY

CARROLL COUNTY, MARYLAND
DEPARTMENT OF PUBLIC WORKS

K. Stinson 4-12-94
DIRECTOR DATE

**MULTI-FAMILY DEVELOPMENT
SCHEMATIC LAYOUTS
FOR PARKING COURTS**

PLATE
36

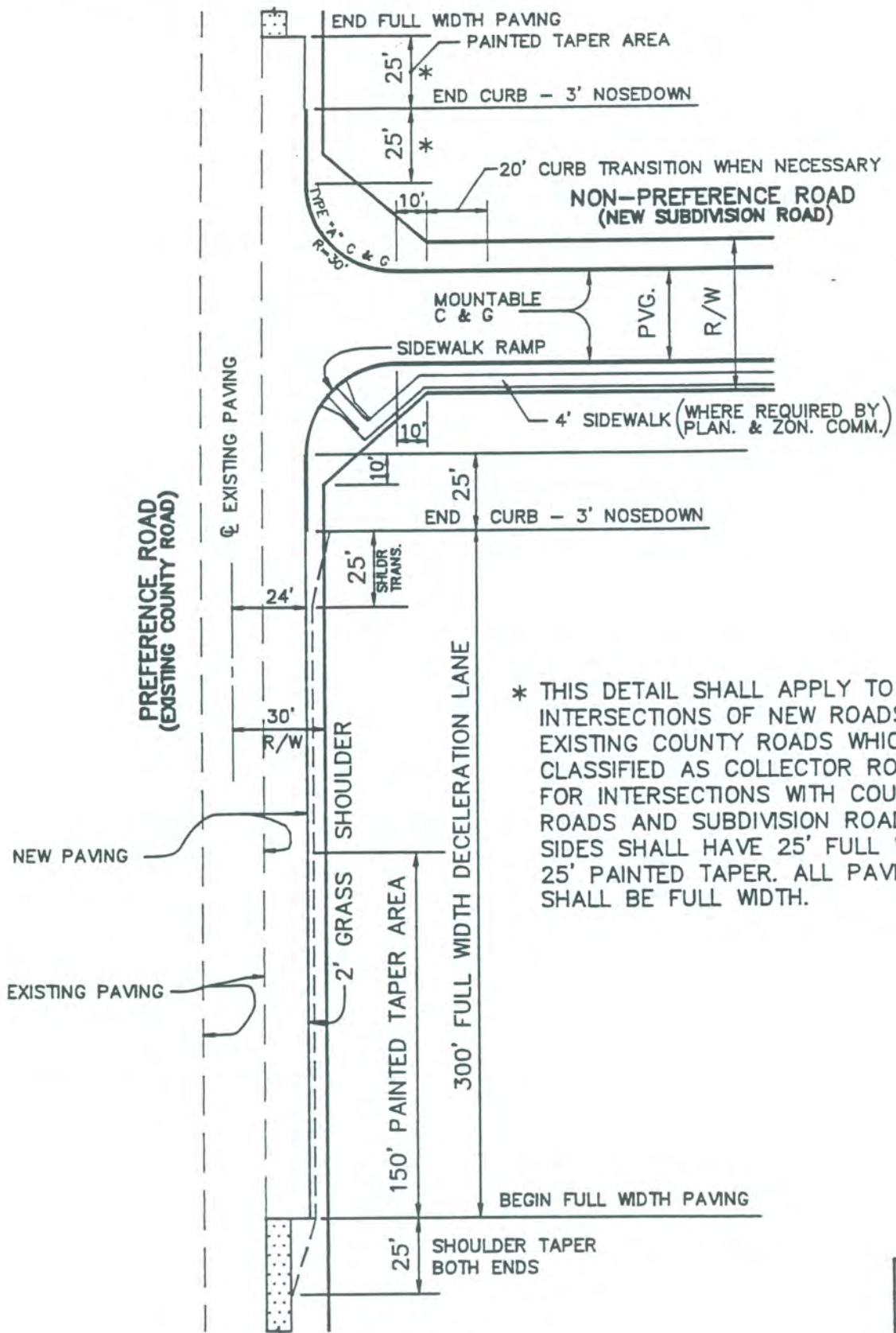

* THIS DETAIL SHALL APPLY TO INTERSECTIONS OF NEW ROADS WITH EXISTING COUNTY ROADS WHICH ARE CLASSIFIED AS COLLECTOR ROADS. FOR INTERSECTIONS WITH COUNTY LOCAL ROADS AND SUBDIVISION ROADS BOTH SIDES SHALL HAVE 25' FULL WIDTH AND 25' PAINTED TAPER. ALL PAVING SHALL BE FULL WIDTH.

REVISED	
DATE	BY

CARROLL COUNTY, MARYLAND
DEPARTMENT OF PUBLIC WORKS

K. S. ... 4-12-94
DIRECTOR DATE

INTERSECTION DETAIL

PLATE
37

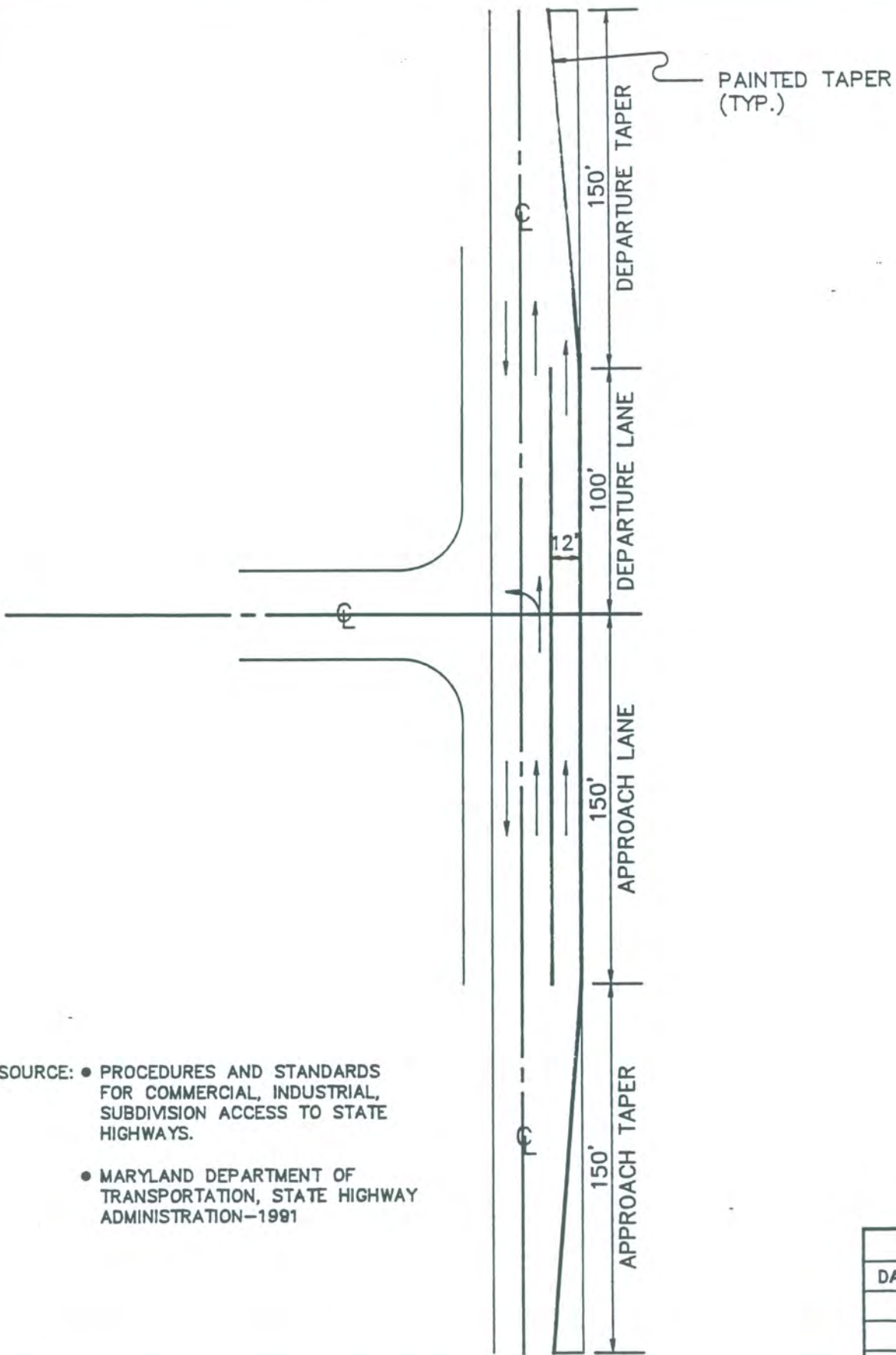

SOURCE: ● PROCEDURES AND STANDARDS FOR COMMERCIAL, INDUSTRIAL, SUBDIVISION ACCESS TO STATE HIGHWAYS.

● MARYLAND DEPARTMENT OF TRANSPORTATION, STATE HIGHWAY ADMINISTRATION-1991

REVISED	
DATE	BY

CARROLL COUNTY, MARYLAND
DEPARTMENT OF PUBLIC WORKS

K. J. ... 4-12-94
DIRECTOR DATE

TYPICAL BY-PASS LANE
AT A "T" INTERSECTION

PLATE
38

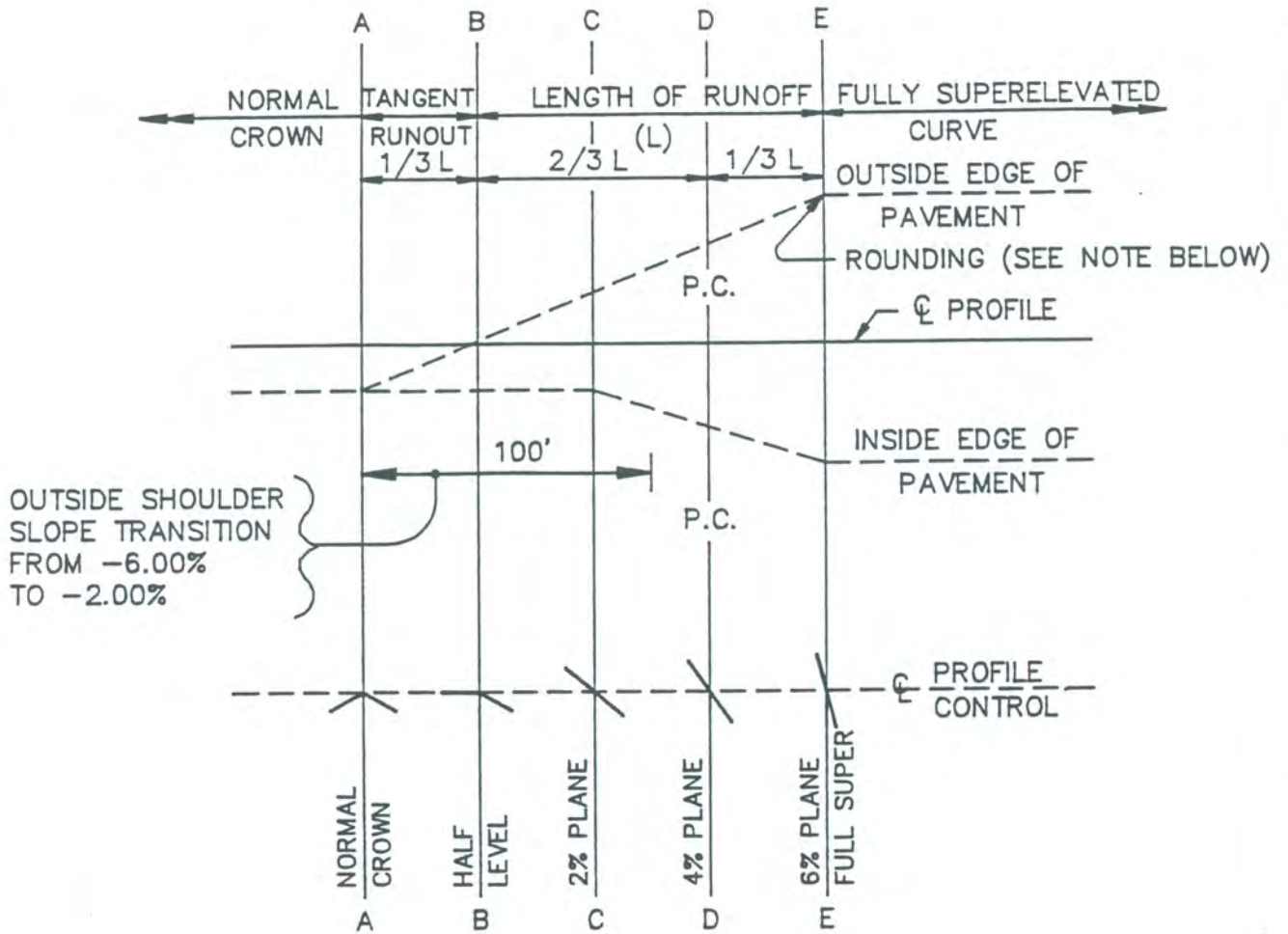

OUTSIDE SHOULDER SLOPE TRANSITION FROM -6.00% TO -2.00%

NOTES:

1. ANGULAR BREAKS IN SECTION TO BE ROUNDED TO PROVIDE SMOOTH TRANSITIONS.
2. POINTS A, B, C, D, & E ARE TO BE STATIONED AND IDENTIFIED IN PLAN, PROFILE, AND TRANSITION DATA TABLE.
3. MAXIMUM RATE OF SUPERELEVATION (e) SHALL BE 0.06 FEET PER FOOT (6.00%).
4. SHOULDER ON HIGH SIDE TO SLOPE DOWNWARD AWAY FROM ROADWAY AT 2.00%.

REVISED	
DATE	BY

CARROLL COUNTY, MARYLAND
 DEPARTMENT OF PUBLIC WORKS
Carroll County
 DIRECTOR
 4-12-94
 DATE

CROWNED PAVEMENT
 REVOLVED ABOUT CENTERLINE

PLATE
 39

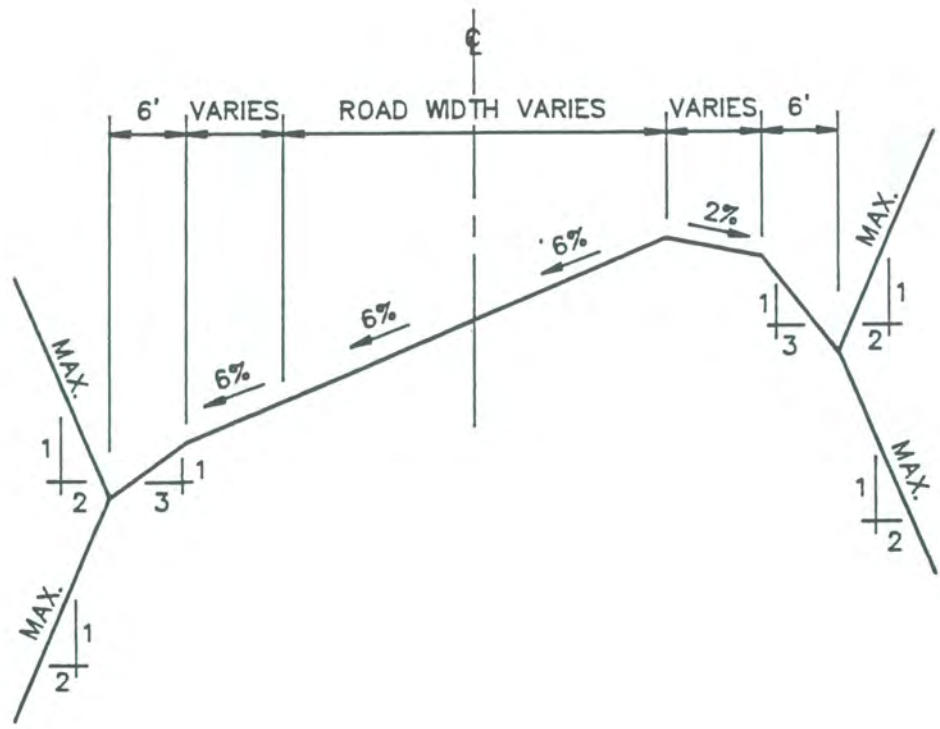

REVISED	
DATE	BY

CARROLL COUNTY, MARYLAND
DEPARTMENT OF PUBLIC WORKS

[Signature] 4-12-94
DIRECTOR DATE

SCHEMATIC SECTION
FULL SUPERELEVATION

PLATE

40

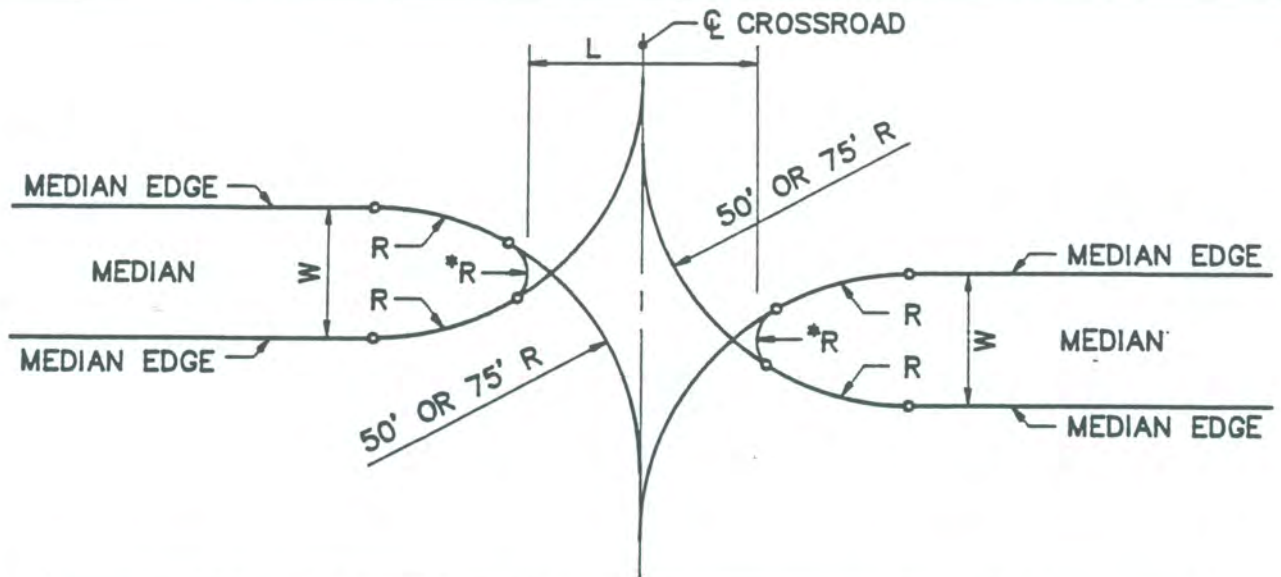

MINIMUM LENGTH OF MEDIAN OPENING		(L IN FEET)	
W		R=50	R=75
4		96	146
6		94	144
8		68	110
10		62	105
12		58	100
14		53	96
16		50	92
20		44	85
24		40	78
28		40	73
32		40	67
36		40	62
40		40	57
50		40	50
60		40	40

NOTE

1. FOR 4' AND 6' ISLAND WIDTHS USE SEMICIRCULAR END.
2. *R = W/5
3. IN NO CASE SHALL L BE LESS THAN THE CROSSROAD PAVING WIDTH PLUS 8 FEET.

SOURCE: A POLICY ON GEOMETRIC DESIGN OF RURAL HIGHWAYS, PP. 407-423 (REF. 1)

REVISED	
DATE	BY

CARROLL COUNTY, MARYLAND
DEPARTMENT OF PUBLIC WORKS

Edward J. ... 4-12-94
DIRECTOR DATE

MEDIAN OPENINGS

PLATE

41

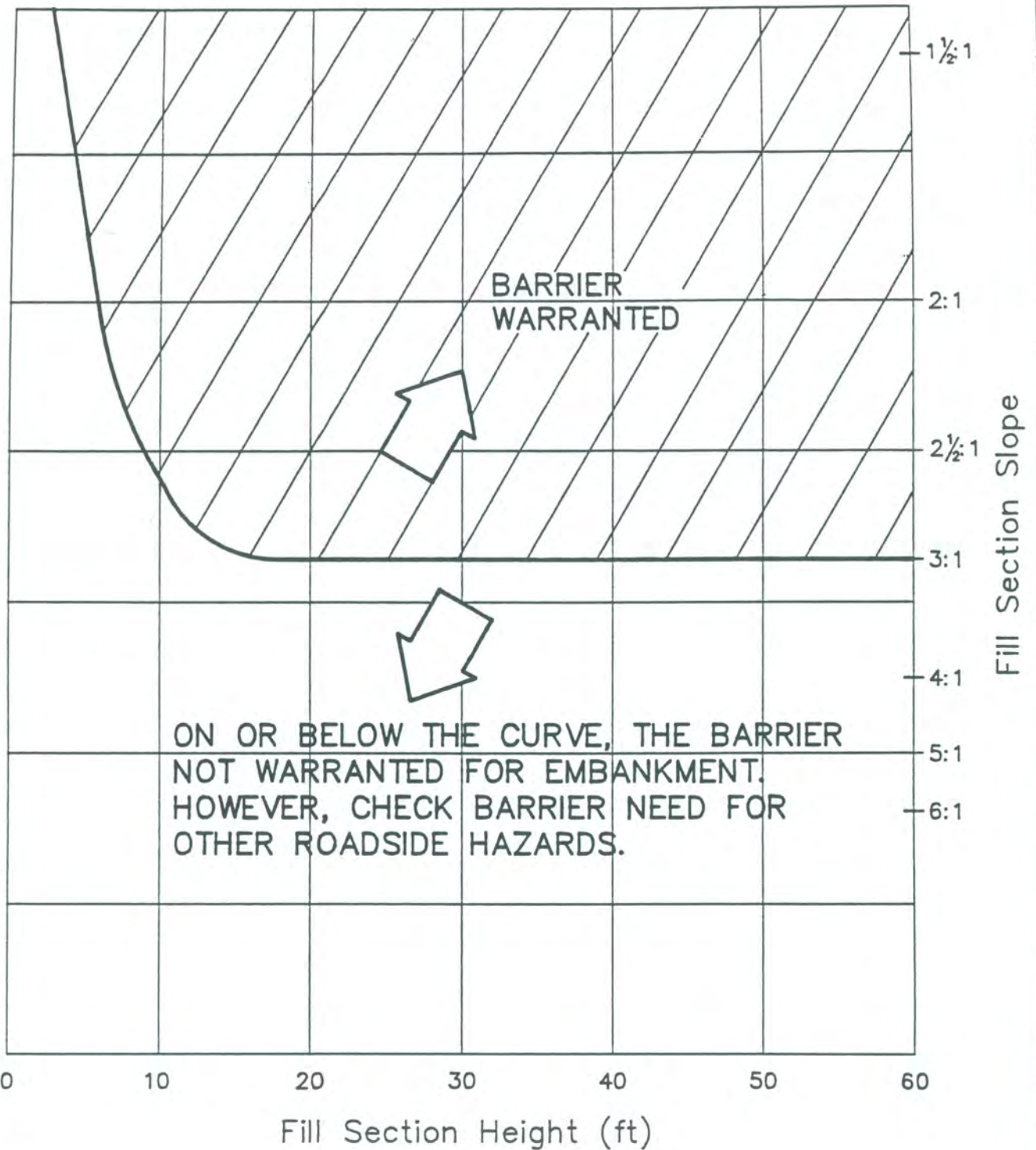

SOURCE: GUIDE FOR SELECTING, LOCATING, AND DESIGNING TRAFFIC BARRIERS (AASHTO, 1977 EDITION)

REVISED	
DATE	BY

CARROLL COUNTY, MARYLAND
DEPARTMENT OF PUBLIC WORKS

K. S. ...
DIRECTOR 4-12-94
DATE

GUARDRAIL REQUIREMENT
CHART

PLATE

42

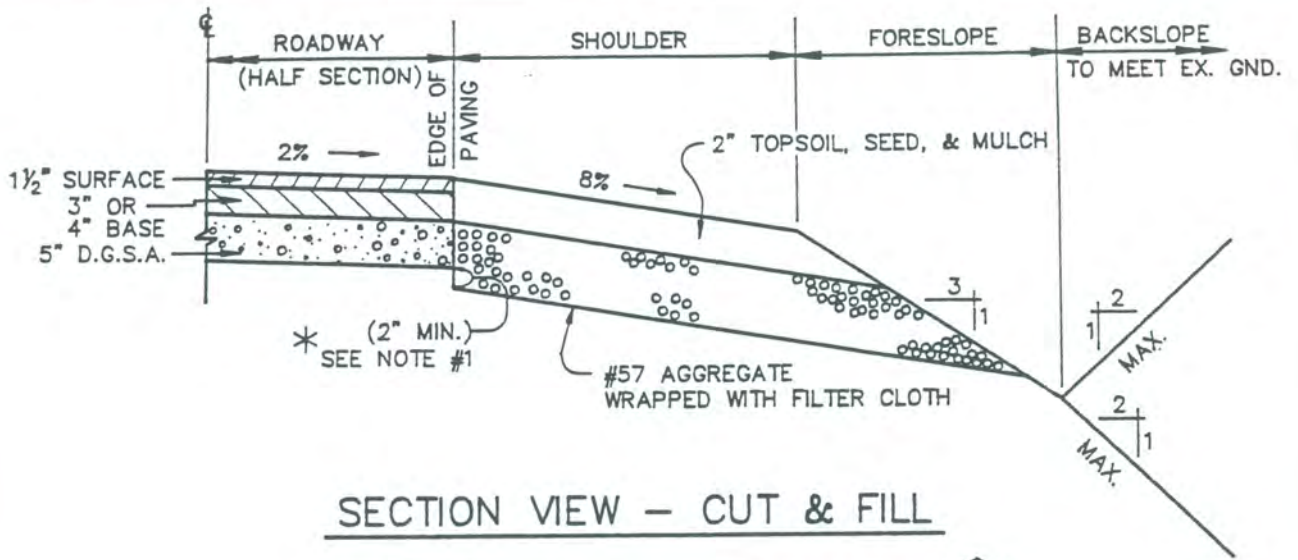

SECTION VIEW - CUT & FILL

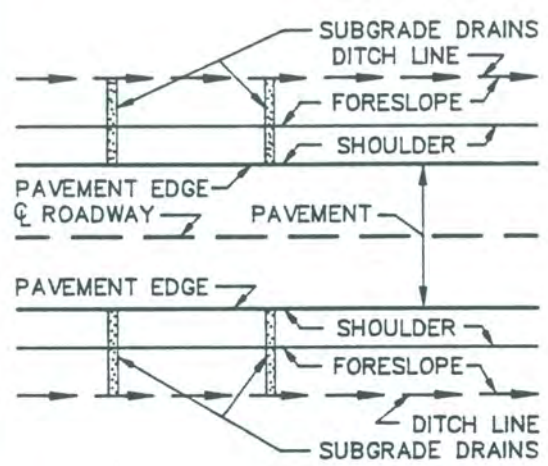

PLAN VIEW

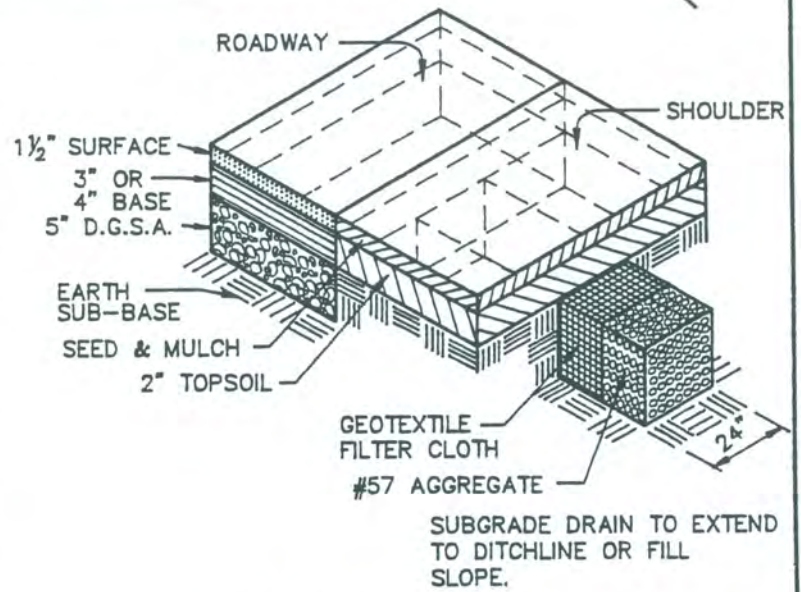

ISOMETRIC VIEW

NOTES:

1. EXTEND DEPTH AS NECESSARY TO MEET DITCHLINE STABILIZATION.
2. DESIGN ENGINEER TO SHOW ACTUAL DIMENSIONS FOR ROADWAY, SHOULDER, AND FORESLOPE ON CONSTRUCTION DRAWINGS.
3. CONSTRUCTION AND MATERIALS SHALL BE IN ACCORDANCE WITH SECTION 306; SUBSECTION 306.03.06 OF THE MARYLAND STATE HIGHWAY ADMINISTRATIONS OCTOBER, 1983 STANDARD SPECIFICATIONS FOR CONSTRUCTION AND MATERIALS.
4. IN NORMAL, CROWNED SECTIONS UNDERDRAINS TO BE PLACED IN SUMP AND AT 25 FOOT INTERVALS FOR 125 FEET UPGRADE FROM SUMP THEN AT 100 FOOT INTERVALS TO WITHIN 125 FEET OF HILL CREST.
5. IN SUPERELEVATED SECTIONS, UNDERDRAINS SHALL BE PLACED AS NOTED ABOVE BUT ON LOW SIDE ONLY AND SHALL EXTEND FROM HALF LEVEL SECTION AT BEGINNING OF CURVE TO HALF LEVEL SECTION AT END OF CURB.
6. FILTER CLOTH SHALL CONFORM TO S.H.A. CLASS "C" SPECIFICATION.

REVISED	
DATE	BY

CARROLL COUNTY, MARYLAND
DEPARTMENT OF PUBLIC WORKS

W. St. ... 4-12-94
DIRECTOR DATE

SUBGRADE DRAINS FOR
FLEXIBLE PAVING

PLATE
43

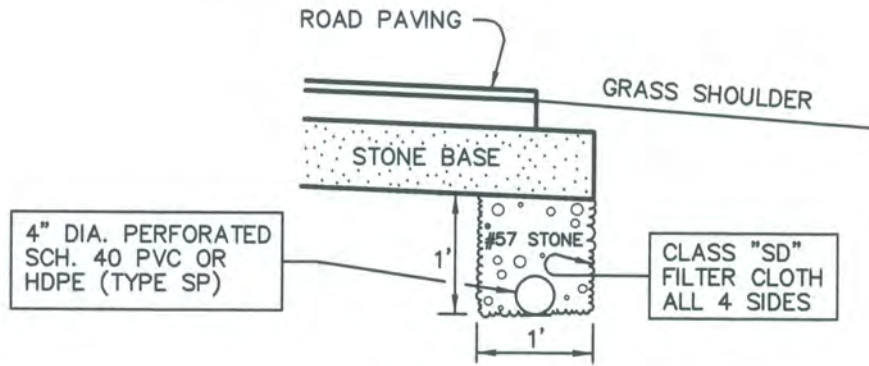

SUBGRADE DRAIN
NTS

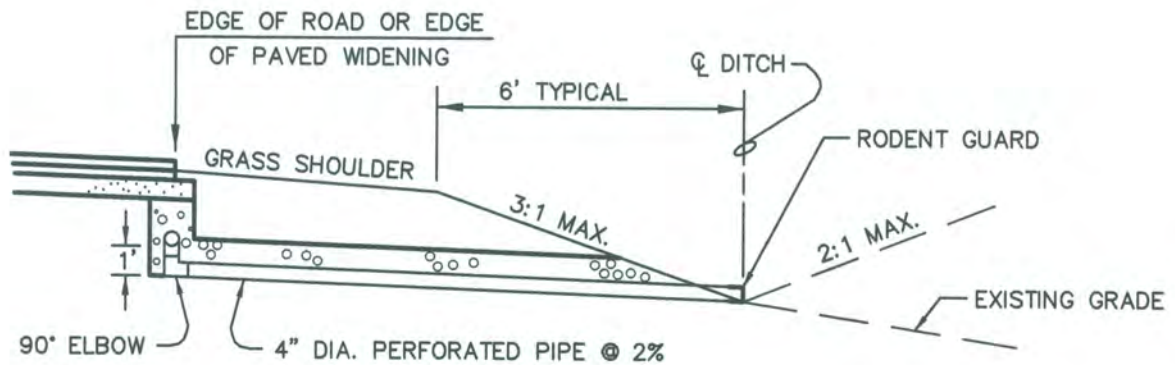

OUTFALL DETAIL
NTS

NOTES:

General: Subgrade drains (Drains) shall run continuously with both edges of road or paved shoulder. Where road improvements are being made along an existing county road which includes the addition of a paved widening such as a turn lane, by-pass lane or auxiliary lane, subgrade drains shall be installed.

Pipe for Drains shall be 4" I.D. perforated Schedule 40 PVC or HDPE (type SP). Stone shall be clean #57 aggregate. Trench shall be lined on all 4 sides with permeable filter cloth. Prefabricated fittings shall be used for abrupt change in direction or when joining pipe systems. Fittings will not be required for normal undulations in road profile.

Filter cloth shall conform to Class "SD" specifications.

Outfall: Outfalls shall be constructed at downgrade ends of subgrade drains and at sumps in road profile using same materials and specifications as for Drains. Outfalls must daylight. Outfall may run with/beneath centerline of ditch if necessary to daylight.

Where outfall will be placed in upland areas, a standard 5" Concrete Gutter will be used, see Plate 44. Final 10' section of pipe shall be non-perforated, trench for final 10' section shall be backfilled with earth.

REVISED	
DATE	BY
10/24/03	R.C.

CARROLL COUNTY, MARYLAND
DEPARTMENT OF PUBLIC WORKS

Douglas E. Myer 2-10-04
DIRECTOR DATE

SUBGRADE DRAINS

PLATE

43-A

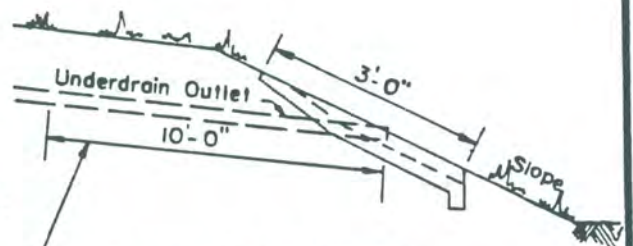
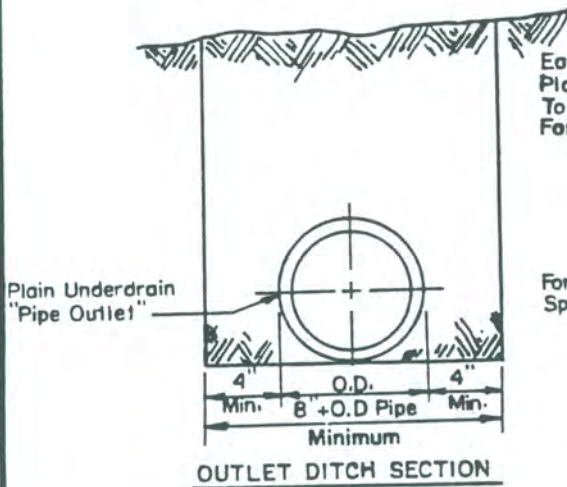
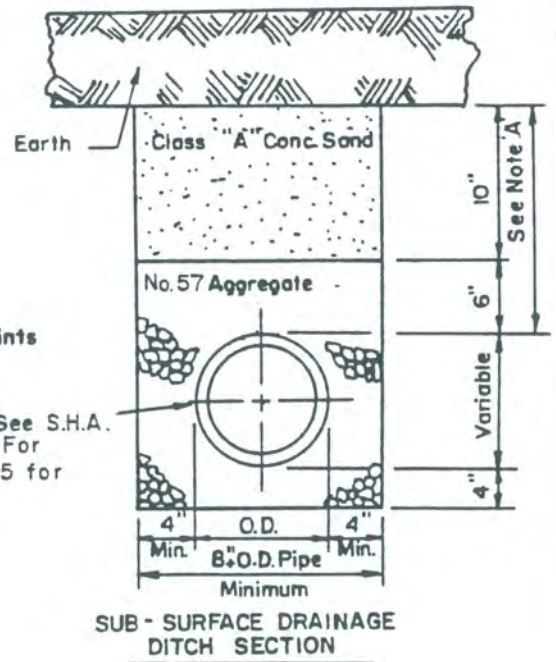
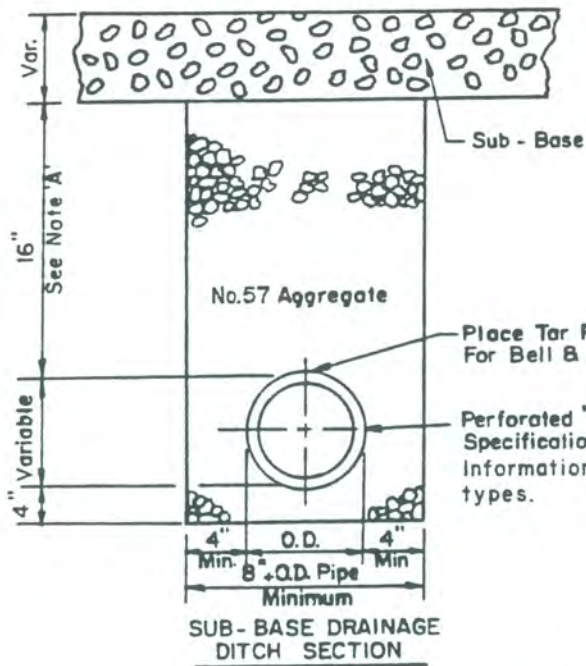

This Length To Be Measured And Paid For At Contract Unit Price For Underdrain Outlet.

5" CONCRETE GUTTER FOR UNDERDRAIN OUTLET

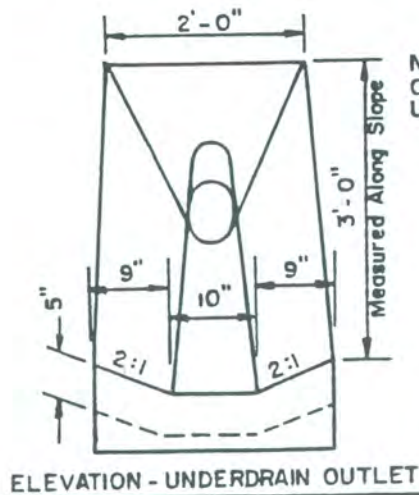

Note: Underdrain To Be Laid On A Minimum Of 0.5% Grade Unless Otherwise Directed.

* Note 'A': Where Underdrain Is Outletted Into An Inlet, Or Where Any Other Unusual Conditions Prevail, These Dimensions May Be Varied As Directed.



REVISED	
DATE	BY
PLATE	

CARROLL COUNTY, MARYLAND
DEPARTMENT OF PUBLIC WORKS

K. St. ... 4-12-94
DIRECTOR DATE

STANDARD UNDERDRAINS

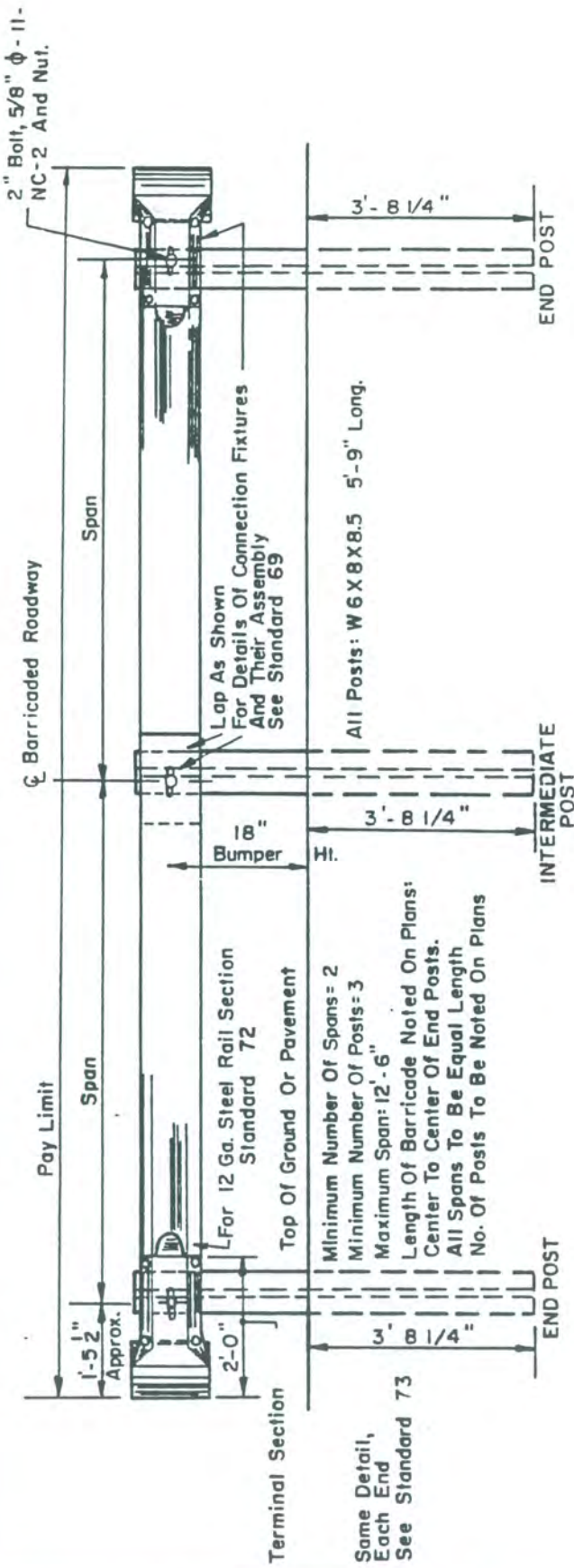

The Linear Foot Price Bid For "Beam Type Barricade" Shall Include The Furnishing And Installation, At Locations Noted On The Plans Or Where Directed By The Engineer, Of Steel Posts, Standard 12 Ga. "Steel Beam Guard Rail," 5/8" Diam. Post And Splicing Bolts, Terminal And Intermediate Splicing Sections, Galvanizing, The Cost Of All Excavation, Backfilling And Tamping Incidental To Setting The Posts, Or The Cost Of Driving The Posts, The Cost Of Removal Of Existing Pavement, Where Necessary, As Well As The Cost Of All Labor, Approved Tools And Equipment Incidental To Furnishing And Installing The Barricade.

Note: For Material Specifications See Latest Specifications For Standard "Beam Type Guard Rail" Beams, Posts, And All Hardware To Be Galvanized As Required By The Specifications. Add Standard Type 7' Traffic Posts & Reflective Delineators In Back Of Barricade Height 4'-0".

CARROLL COUNTY, MARYLAND
DEPARTMENT OF PUBLIC WORKS

K. Skindred 4-12-94
DIRECTOR DATE

BEAM TYPE
BARRICADE

REVISED	
DATE	BY

PLATE

45

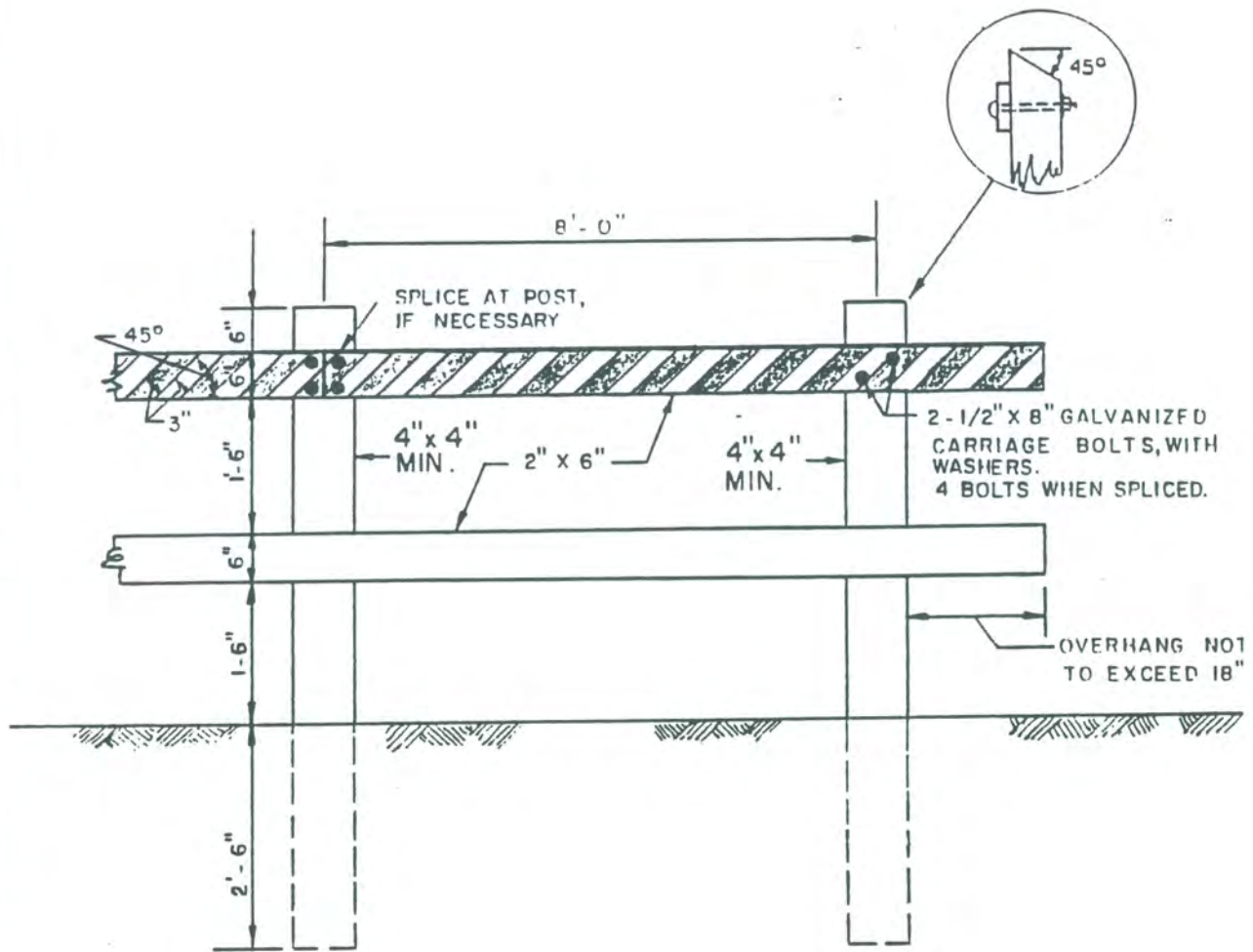

TYPICAL SECTION

NOTE:

1. LUMBER TO BE OF PRESSURE TREATED GRADE.
2. THE UPRIGHTS AND CROSS PIECES SHALL BE PAINTED WHITE WITH TWO COATS OF APPROVED EXTERIOR PAINT.
3. THE TOP CROSS PIECE SHALL HAVE ORANGE STRIPES AS SHOWN.
4. CONSTRUCT TO FULL WIDTH OF RIGHT-OF-WAY OR AS DIRECTED.
5. THE STRIPING SHALL BE DIRECTED TOWARDS THE CENTER OF THE ROADWAY TO PRODUCE A CHEVRON EFFECT.

REVISED	
DATE	BY

CARROLL COUNTY, MARYLAND
DEPARTMENT OF PUBLIC WORKS

Kendrick 4-12-94
DIRECTOR DATE

TIMBER BARRICADE

PLATE

46

1-1/2" LAYER BITUMINOUS CONCRETE-SURFACE COURSE (SF BAND)
 2 LAYERS BASE COURSE - 7 1/2" TOTAL { 1-4" LAYER.
 1-3 1/2" LAYER

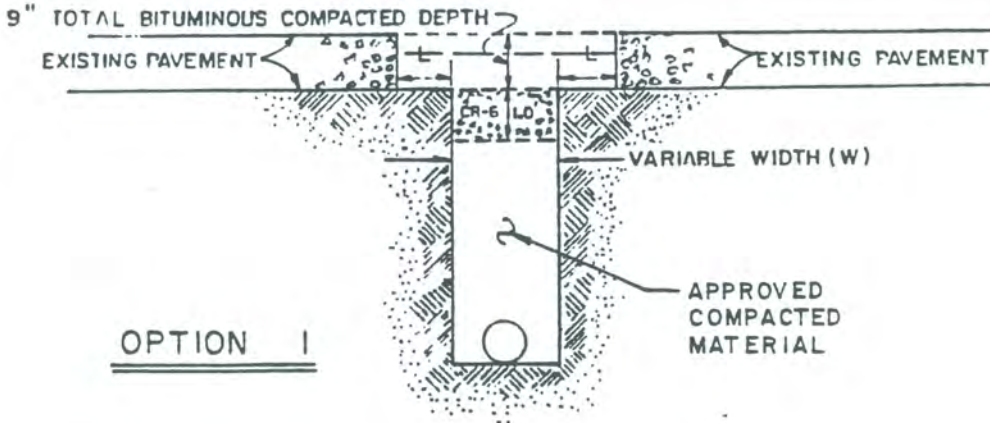

OPTION 1

W'	L'
1'	1'
1.5'	1.5'
≥ 2'	2'

1 - 2" LAYER BITUMINOUS CONCRETE SURFACE COURSE (SF BAND)
 1 - 9" LAYER CONCRETE

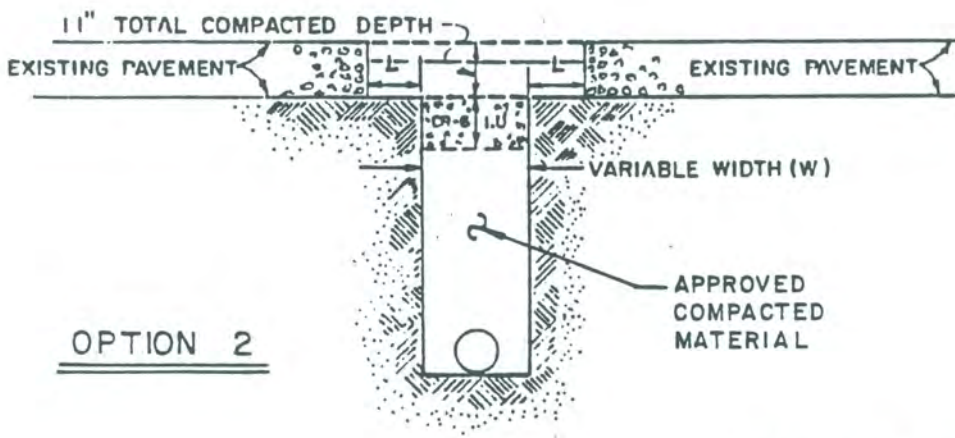

OPTION 2

W'	L'
1'	1'
1.5'	1.5'
≥ 2'	2'

(A) PAVING PATCH SHALL MATCH EXISTING PAVING THICKNESS OR A MINIMUM OF 3 1/2" BASE COURSE AND 1 1/2" SURFACE COURSE.

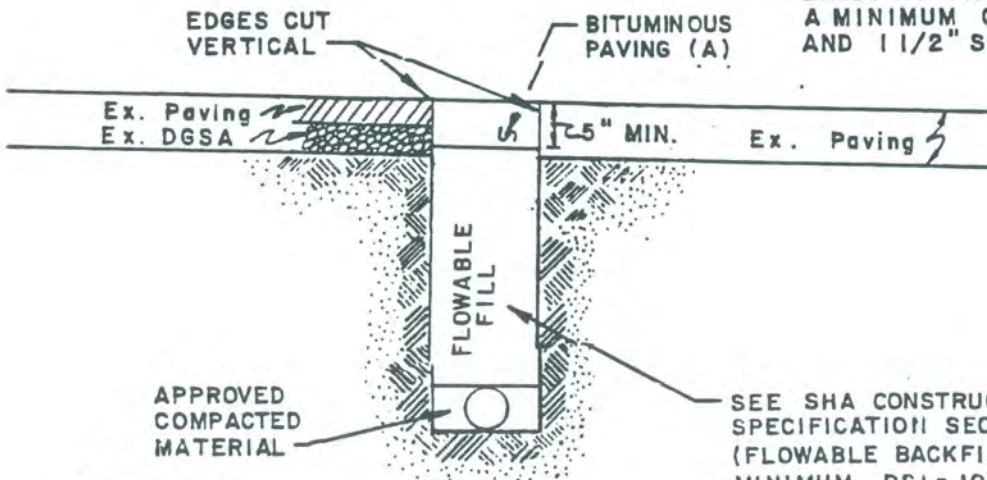

OPTION 3

W'	L'
1'	N/A
1.5'	N/A
≥ 2'	N/A

SEE SHA CONSTRUCTION SPECIFICATION SECTION 313 (FLOWABLE BACKFILL) MINIMUM PSI = 100, MAX. = 150 PSI

REVISED	
DATE	BY

CARROLL COUNTY, MARYLAND
 DEPARTMENT OF PUBLIC WORKS

METHOD OF CUTTING AND REPAIRING ROADWAYS

Handwritten signature 4-12-94
 DIRECTOR DATE

PLATE

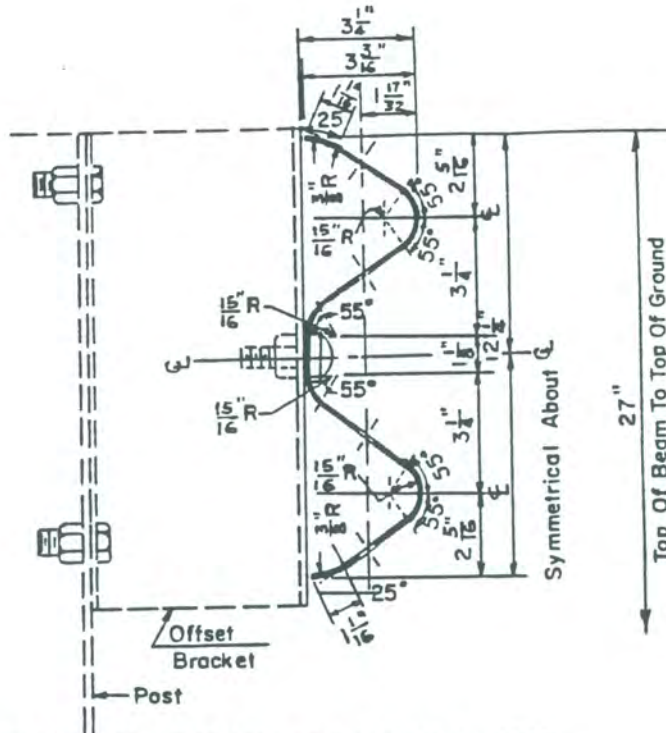

SECTION THRU RAIL ELEMENT MATERIAL: 12 GA. STEEL

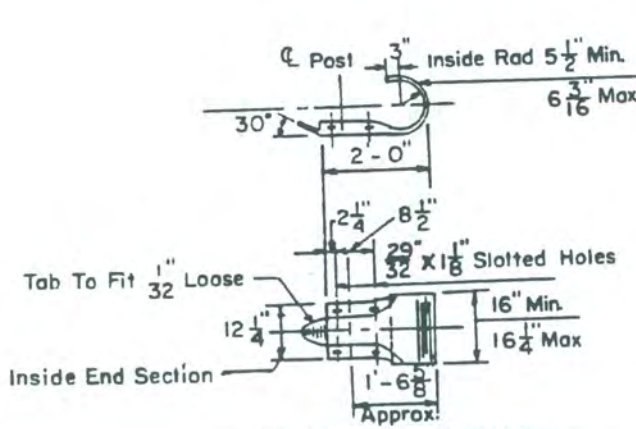

GUARD RAIL - END SECTION MATERIAL: 10 GA. STEEL

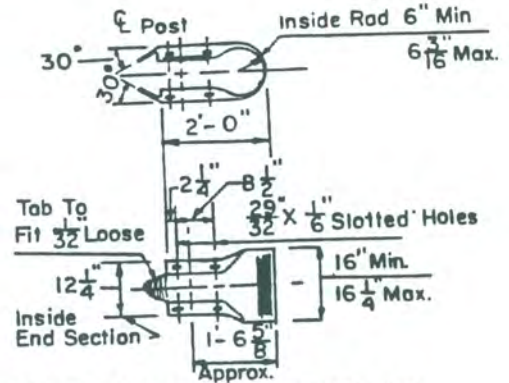

GUARD RAIL BARRIER - END SECTION (For Rail On Both Sides Of Same Post) MATERIAL: 10 GA. STEEL

General Notes:

1. All Dimensions Are Subject To MFG Tolerances.
2. Rail Elements Are Furnished Shop Curved, Concave Or Convex To Radial Between 20 Ft & 150 Ft.
3. The Steel For Rail Elements And Bolts Is Of A Quality To Develop Specification Values For Beam And Tensile Strengths.
4. For Materials, Material Processing And Assembly, See Latest Specifications.
5. For Offset Bracket Detail, See ST'D. 72.
6. Posts To Be W6 X 8.5, 5'-9" Long, Spaced At 6'-3" c/c.
7. Back-Up Plate (12" Length Of Beam) Centered On Offset Bracket Bolt. To Be Placed Where No Overlap Of Rail Splice Occurs.

CARROLL COUNTY, MARYLAND
DEPARTMENT OF PUBLIC WORKS

Handwritten signature 4-12-94
DIRECTOR DATE

GUARD RAIL W/ BEAM
DETAILS

REVISED

PLATE

48

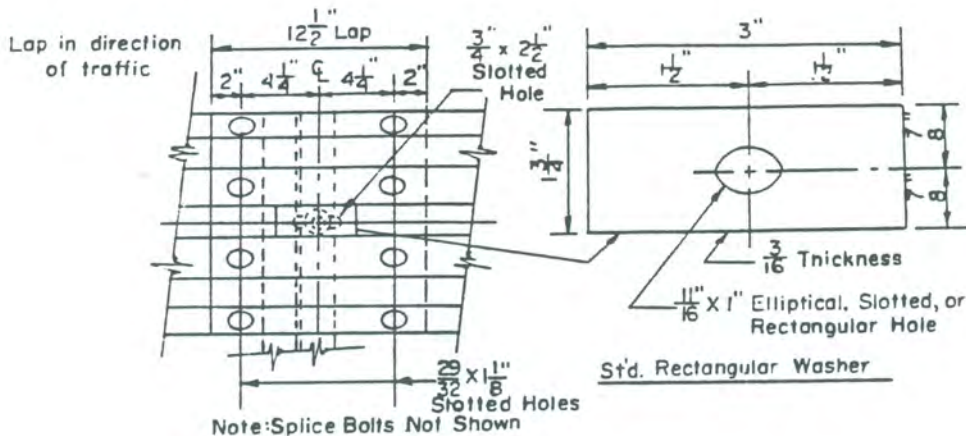

GUARD RAIL SPLICE

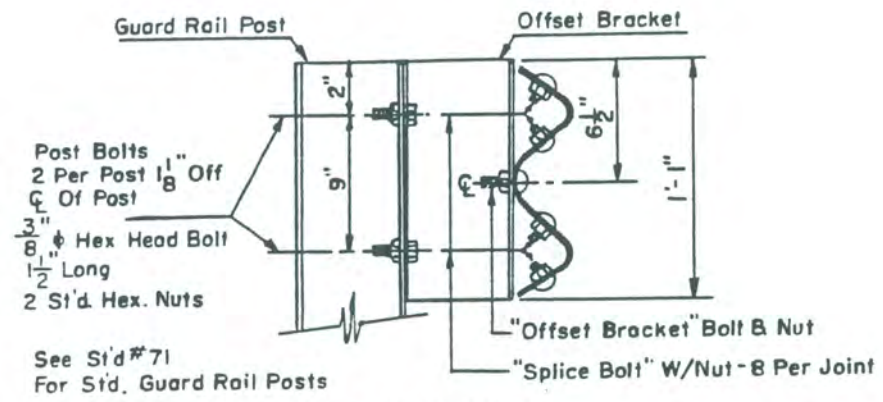

OFFSET BRACKET
6 WF 8.5

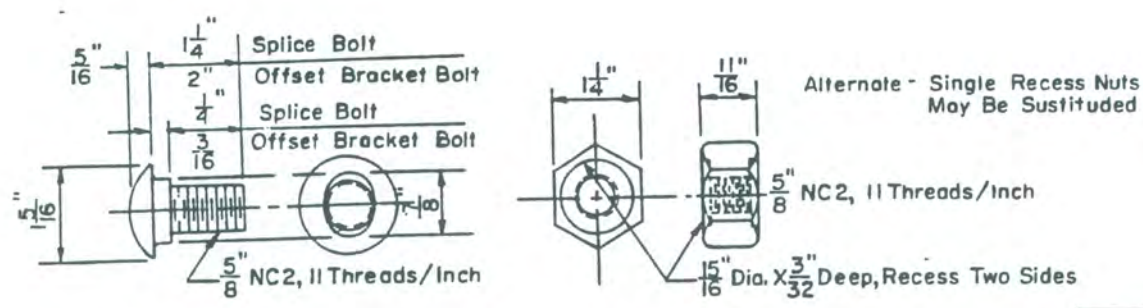

"Splice Bolt" & "Offset Bracket Bolt"
8 Per Joint 1 Per Bracket
1 1/4" Long 2" Long

Nut
9 Per Splice

REVISED	
DATE	BY

CARROLL COUNTY, MARYLAND
DEPARTMENT OF PUBLIC WORKS

K. D. ... 4-12-94
DIRECTOR DATE

**GUARD RAIL W/ BEAM
SPLICE JOINT**

PLATE

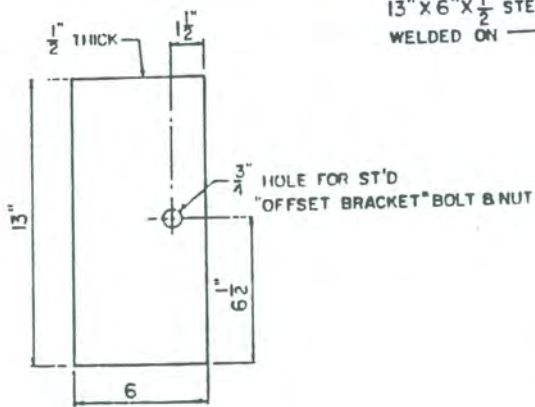

STEEL PLATE DETAIL

NOTE: ALL STEEL IS TO BE AASHTO DESIGNATION M-183 HOT DIPPED GALVANIZED AFTER FABRICATION TO AASHTO DESIGNATION M-111

I BEAM POST CUT ON INDICATED ANGLE β
 13" X 6" X 1/2" STEEL PLATE WELDED ON

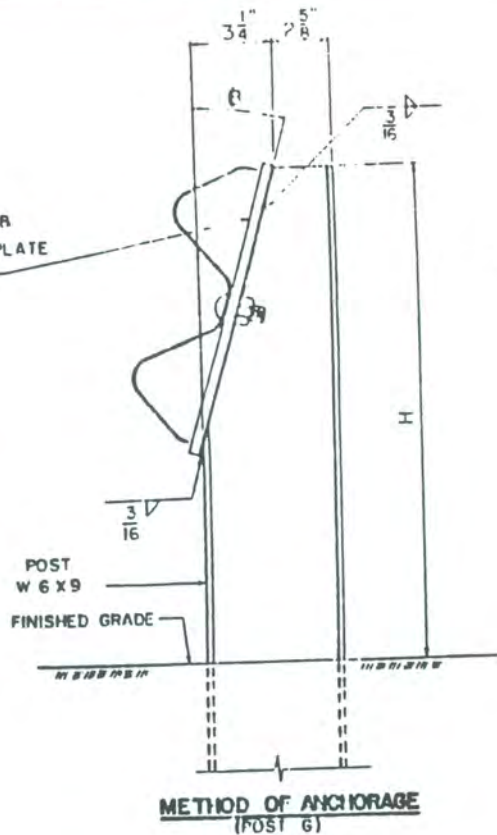

METHOD OF ANCHORAGE (POST G)

H = HEIGHT OF TOP OF BARRIER POST ABOVE FINISHED GRADE
 β = ANGLE OF PITCH OF RAIL

POST	H	β
A	2'-3"	0°
B	2'-3"	0°
C	2'-3"	0°
D	2'-3"	0°
E	2'-3"	0°
F	2'-3"	0°
G	2'-0 1/2"	15°
H	1'-8"	30°
I	1'-2 1/2"	45°
J	0'-9 1/4"	60°
K	0'-4 1/4"	75°
L	0'-0"	90°

NOTE: FOR METHOD OF ANCHORAGE AT POST L, SEE DETAILS ON STANDARD MD-660.31

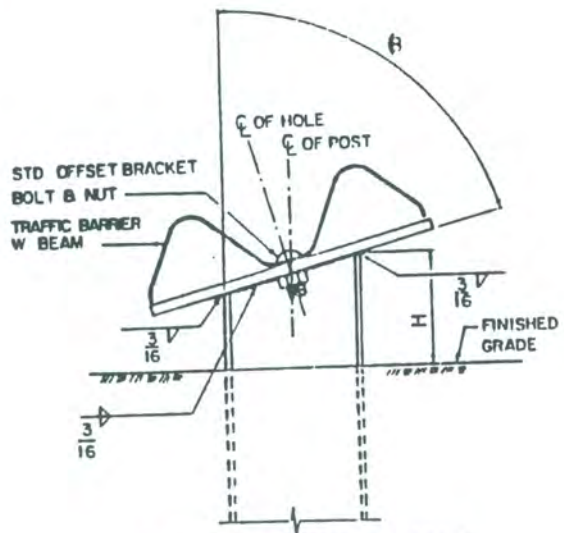

TYPICAL METHOD OF ANCHORAGE (POSTS H, I, J & K)

NOTE: - USE OF ANCHORAGE PLATE IN PLACE OF OFFSET BRACKET BEGINS AT POST G WITH AN ANGLE OF 15°

ANCHORAGE PLATE TO BE USED WITH TYPE I-END FLARE

CARROLL COUNTY, MARYLAND
 DEPARTMENT OF PUBLIC WORKS

Carroll County 4-12-94
 DIRECTOR DATE

TRAFFIC BARRIER W BEAM
 ANCHORAGE PLATE

REVISED	
DATE	BY
PLATE	
50	

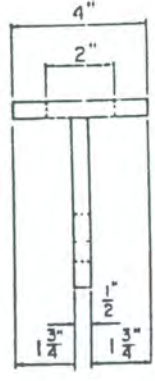
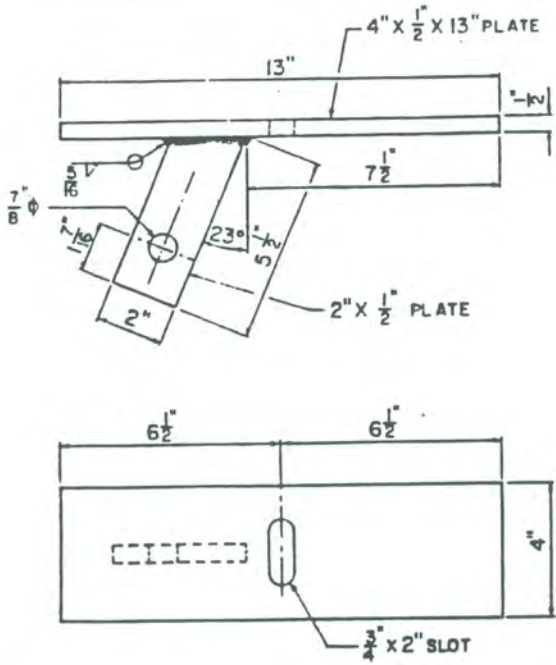

ALL STEEL TO BE AASHTO DESIGNATION M-183
HOT DIPPED GALVANIZED AFTER FABRICATION
TO AASHTO DESIGNATION M-111

H = HEIGHT OF TOP OF BARRIER POST ABOVE FINISHED GRADE
 β = ANGLE OF PITCH OF RAIL

POST	H	β
A	2'-3"	0°
B	2'-3"	0°
C	2'-3"	0°
D	2'-3"	0°
E	2'-3"	0°
F	2'-3"	0°
G	1'-1 3/4"	15°
H	0'-10 1/2"	30°
I	0'-7"	45°
J	0'-4 1/2"	60°
K	0'-1 1/2"	75°
L	0'-0"	90°

NOTE: FOR METHOD OF ANCHORAGE
AT POST L, SEE DETAILS
ON STANDARD.

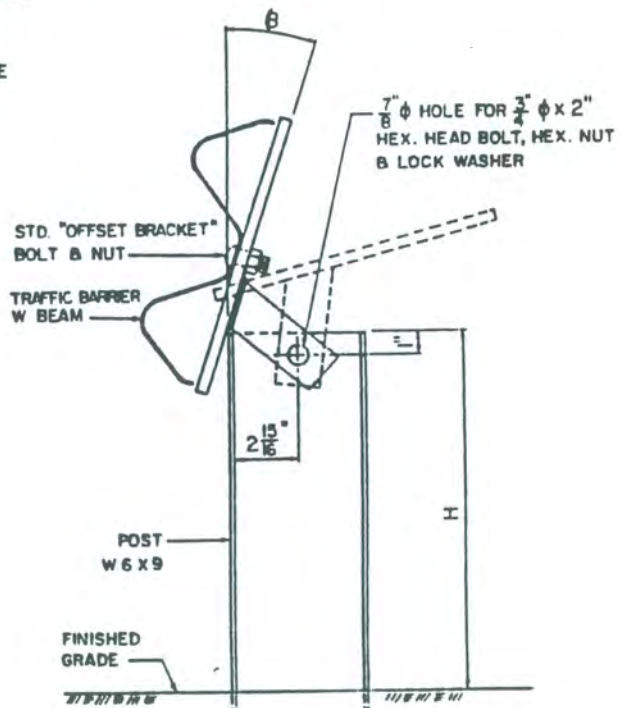

METHOD OF ANCHORAGE

(POSTS G, H, I, J & K)
NOTE: - USE OF ANCHORAGE BRACKET IN PLACE OF
OFFSET BRACKET BEGINS AT POST G
WITH AN ANGLE OF 15°

ANCHORAGE BRACKET TO BE USED WITH TYPE I- END FLARE

REVISED	
DATE	BY

PLATE
51

CARROLL COUNTY, MARYLAND
DEPARTMENT OF PUBLIC WORKS

TRAFFIC BARRIER W BEAM
ANCHORAGE BRACKET

Carroll County 4-12-94
DIRECTOR DATE

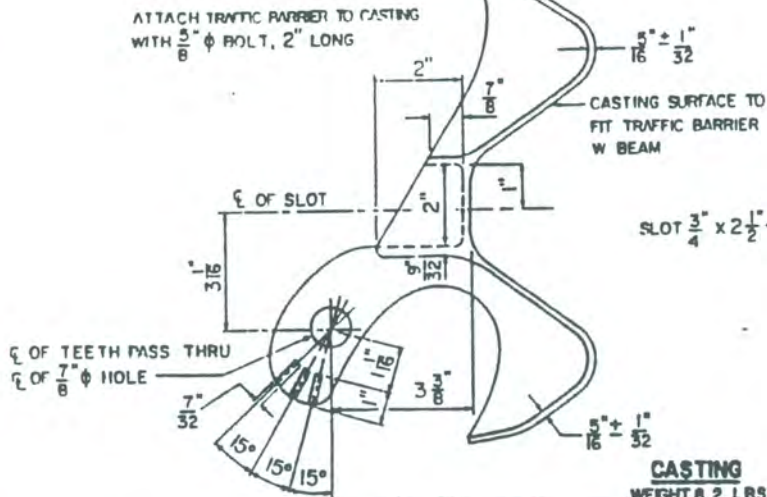

CASTING
WEIGHT 8.2 LBS.

MATERIAL REQUIREMENTS

1. THE METAL CASTING SHALL CONFORM TO THE A.S.T.M. DESIGNATION A-47, GRADE 32510.
2. THE ZINC COATING SHALL CONFORM TO THE DESIGNATION AASHTO M-232
3. ALL PARTS TO BE GALVANIZED.

H = HEIGHT OF TOP OF BARRIER POST ABOVE FINISHED GRADE
β = ANGLE OF PITCH OF RAIL

POST	H	β
A	2'-3"	0°
B	2'-3"	0°
C	2'-3"	0°
D	2'-3"	0°
E	2'-3"	0°
F	2'-3"	0°
G	1'-3 1/2"	15°
H	0'-11 1/8"	30°
I	0'-8 1/2"	45°
J	0'-4 8/8"	60°
K	0'-1"	75°
L	0'-0"	90°

NOTE: FOR METHOD OF ANCHORAGE AT POST L, SEE DETAILS ON STANDARD

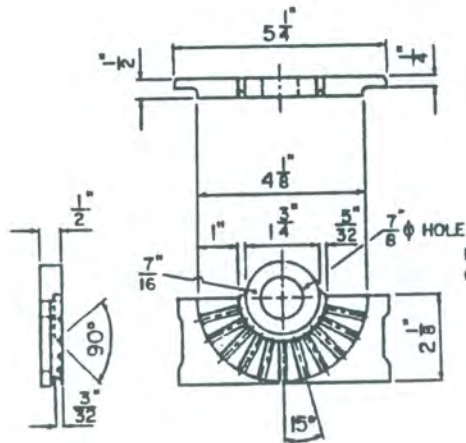

PITCH WASHER
WEIGHT 1 LB.

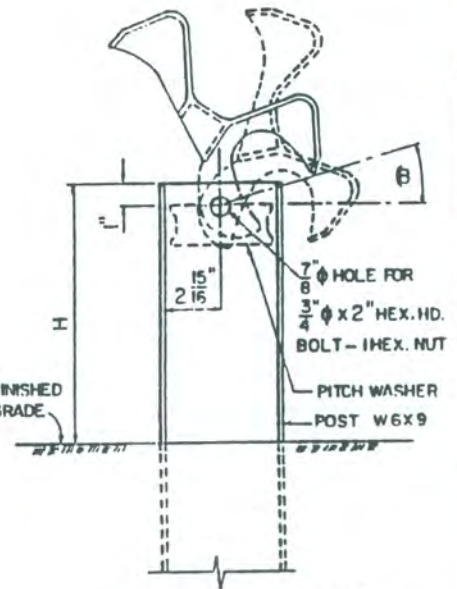

METHOD OF ANCHORAGE

(POSTS G, H, J & K)

NOTE: - USE OF ANCHORAGE CASTING IN PLACE OF OFFSET BRACKET BEGINS AT POST G WITH AN ANGLE OF 15°

ANCHORAGE CASTING TO BE USED WITH TYPE I-END FLARE

CARROLL COUNTY, MARYLAND
DEPARTMENT OF PUBLIC WORKS

**TRAFFIC BARRIER W BEAM
ANCHORAGE CASTING**

Handwritten signature 4-12-94
DIRECTOR DATE

REVISED

PLATE

52

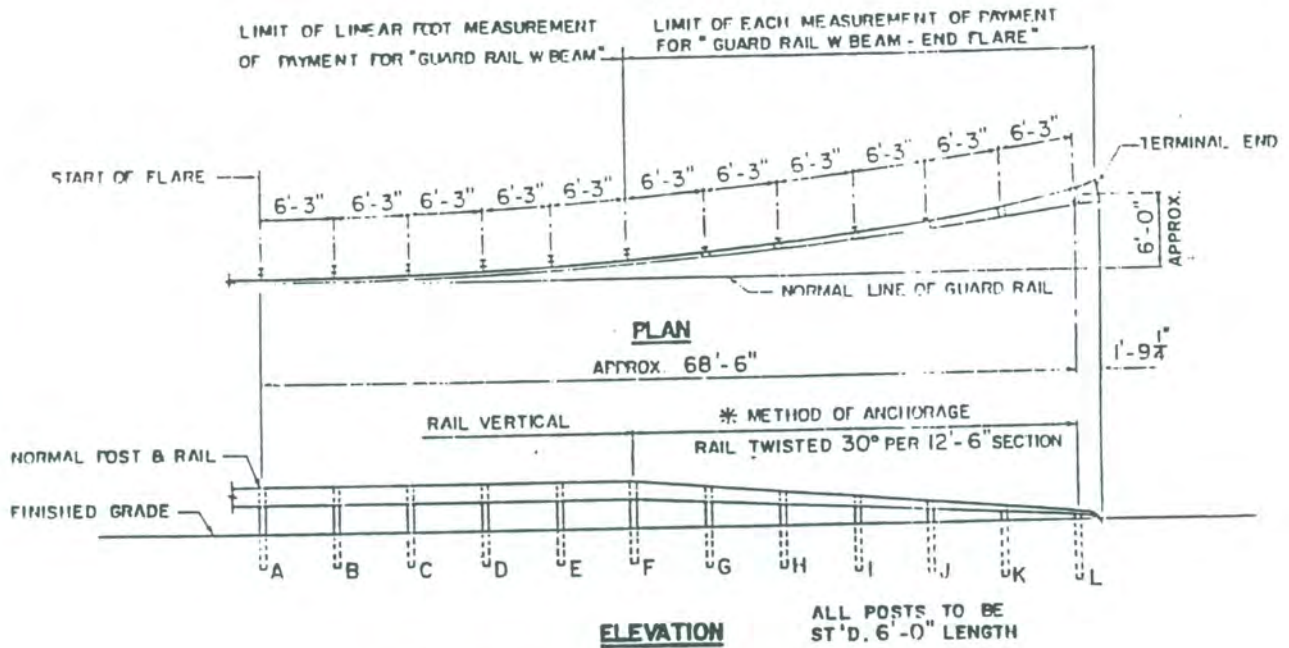

* NOTE: USE OF GUARD RAIL W BEAM ANCHORAGE IN PLACE OF OFFSET BRACKET BEGINS AT POST G. THE CONTRACTOR HAS THE OPTION FOR THE METHOD OF GUARD RAIL W BEAM ANCHORAGE. FOR DETAILS OF OPTIONS SEE - ST'D MD - 660.32 ANCHORAGE CASTING
 ST'D MD - 660.33 ANCHORAGE BRACKET
 ST'D MD - 660.34 ANCHORAGE PLATE

COST OF ANCHORAGE SELECTED SHALL BE INCLUDED IN THE PAYMENT FOR END FLARE AS INDICATED ABOVE.

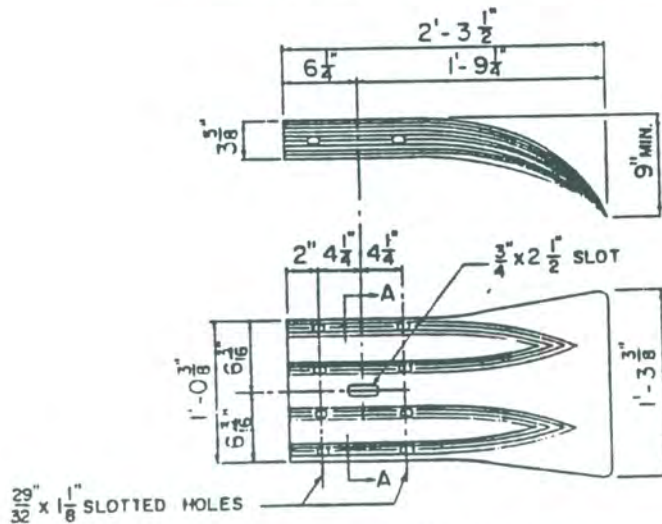

NOTE: TYPE 1- END FLARE WILL BE USED WHERE THE SPACING OF CROSS-STREETS AND ENTRANCES PRECLUDE THE USE OF STANDARD MD-660.35 "TYPE 2- END FLARE."

SECTION A-A

TERMINAL END (10 GA.)

REVISED	
DATE	BY

CARROLL COUNTY, MARYLAND
 DEPARTMENT OF PUBLIC WORKS

Carroll County 4-12-94
 DIRECTOR DATE

GUARD RAIL WITH BEAM
 TYPE 1- END FLARE

PLATE

53

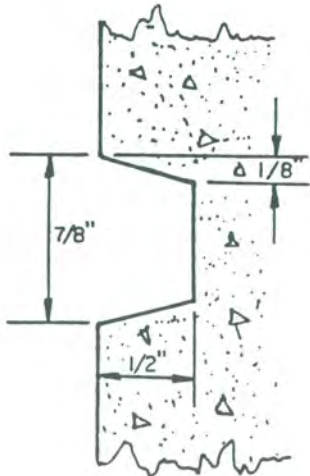
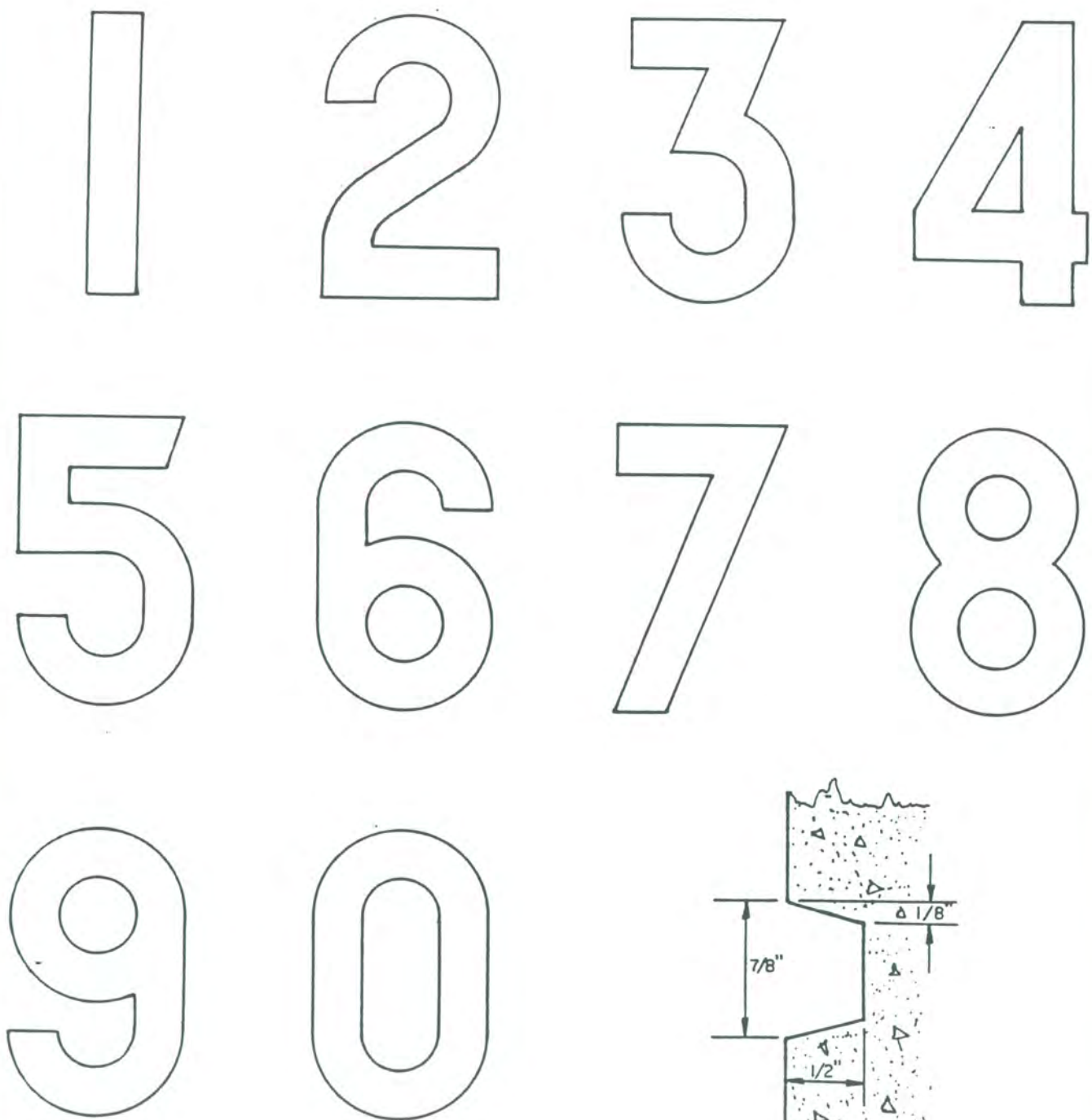

NOTE:
 ALL NUMERALS TO BE 5" HIGH.
 ALL NUMERALS TO BE 3" WIDE OVERALL EXCEPT "1" WHICH WILL BE 7/8" WIDE.

REVISED		CARROLL COUNTY DEPARTMENT OF PUBLIC WORKS	STANDARD "YEAR BUILT" NUMERALS	PLATE
DATE	BY			54
		<i>Carol C. ...</i>	4-12-94	
		DIRECTOR	DATE	

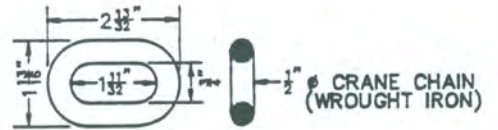
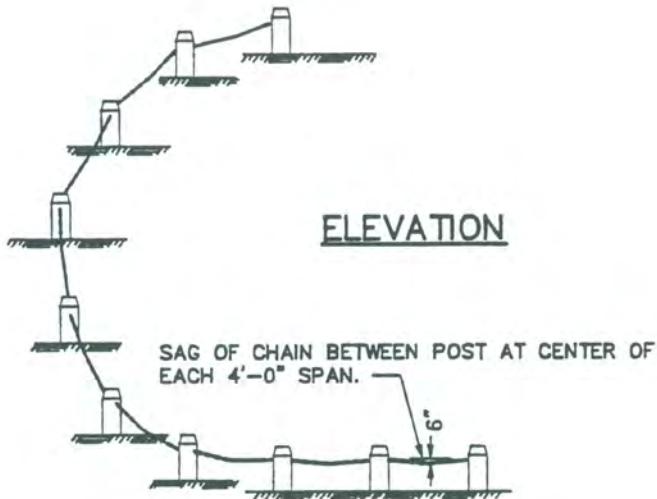
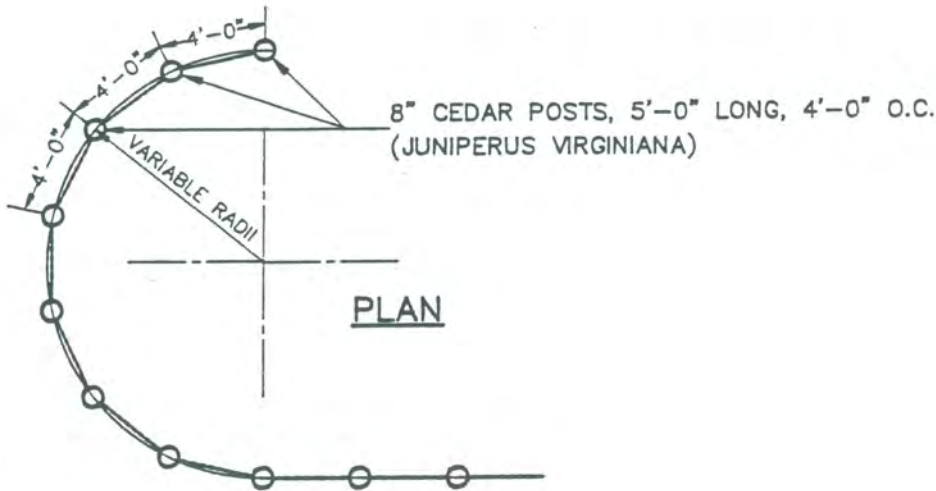

CHAIN LINK DETAIL

LGTH. 100 LINK	134"
WGT./100'	275 POUNDS
BREAK TEST LOAD	14,145 ...
PROOF TEST LOAD	5,375 ...
SAFE WORKING LOAD	4,240 ...

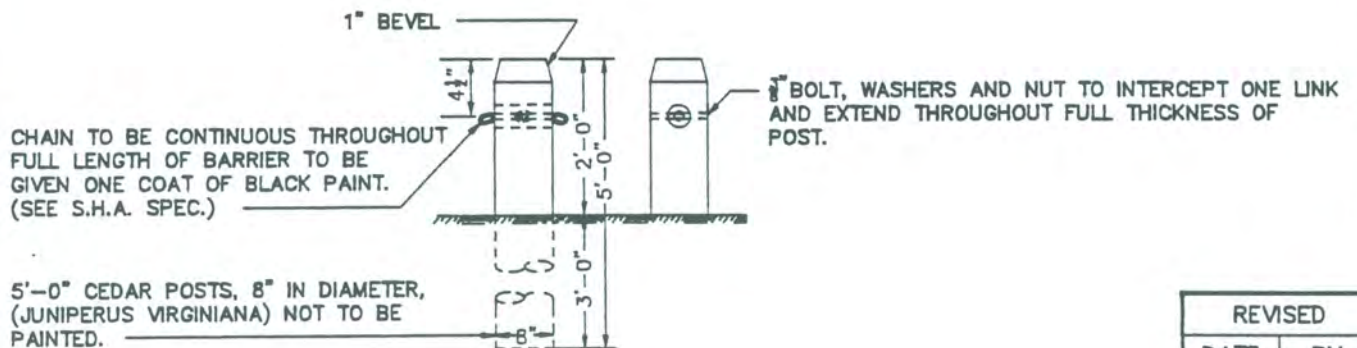

REVISED	
DATE	BY

CARROLL COUNTY, MARYLAND
DEPARTMENT OF PUBLIC WORKS

Carroll County 4-12-94
DIRECTOR DATE

WOODEN POST
AND
CHAIN GUARDRAIL

PLATE

55



THROUGH STREET



LOCATION PLAN

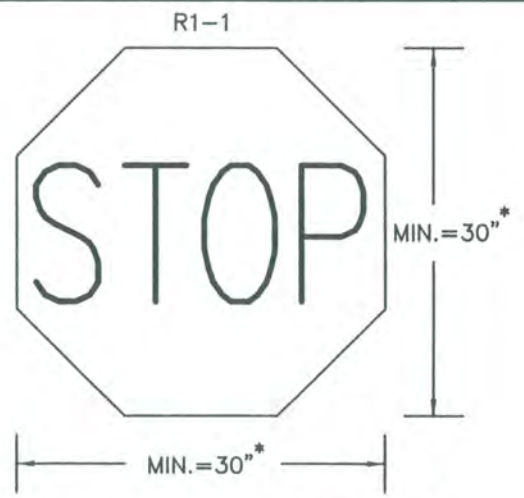

* SIZE VARIES BASED UPON ROADWAY

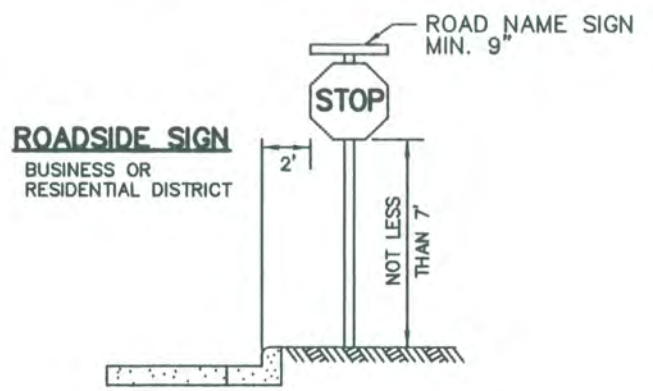

NOTES

1. All signs shall be installed in compliance with the latest edition of The Manual on Uniform Traffic Control Devices(MUTCD).
2. All signs shall be installed in accordance with current Department of Public Works specifications.
3. All signs installed along Maryland State Highway's(MDSHA) shall be installed in accordance with MDSHA standards with exception of the Road Name Sign.

REVISED	
DATE	BY
2-18-04	C.L.

CARROLL COUNTY, MARYLAND
DEPARTMENT OF PUBLIC WORKS
Douglas E. Meyer 2-10-04
DIRECTOR DATE

STANDARD STREET
NAME AND
STOP SIGNS

PLATE
56

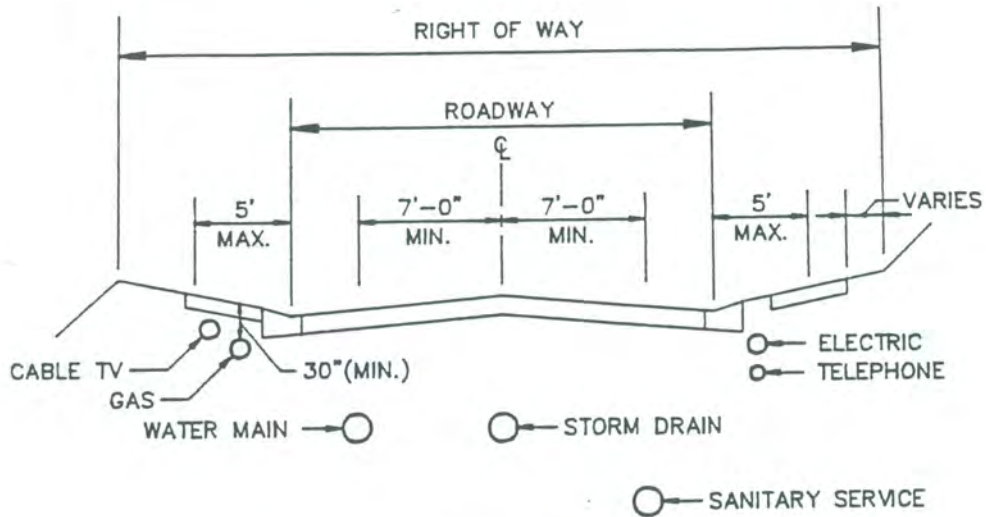

OPTION NO. 1

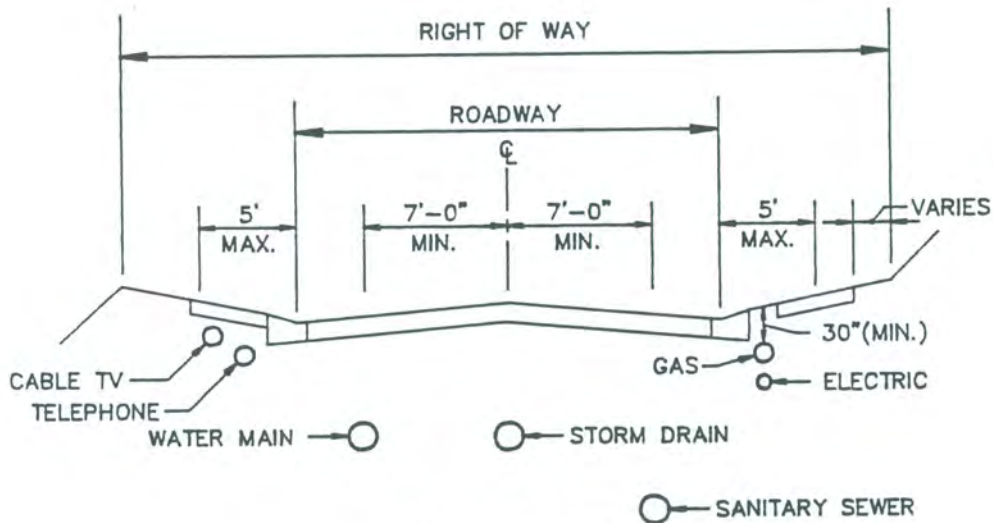

OPTION NO. 2

NOTES:

1. LOCATION FOR UTILITIES (NOT INSTALLED UNDER ROADWAY) SHALL BE LIMITED TO A MAXIMUM OF FIVE FEET (5') BEYOND FLOWLINE OF CURB UNLESS OTHERWISE INSTRUCTED BY D.P.W.
2. DEPARTMENT OF PUBLIC WORKS, CONSTRUCTION INSPECTION DIVISION TO BE CONSULTED PRIOR TO INSTALLATION OF GAS, ELECTRIC, TELEPHONE, OR CABLE TV FACILITIES.
3. GAS, ELECTRIC, AND TELEPHONE UTILITIES MAY BE PLACED IN SAME TRENCH AT THE OPTION OF THE POWER COMPANY AND THE C&P TELEPHONE COMPANY.
4. ELECTRIC: 0-600V 24" COVER, OVER 600V 36" COVER.
 TELEPHONE: MAIN SERVICE 24" COVER.
 RESIDENTIAL CONNECTION 11" COVER.
 CABLE TV: 11" COVER.

REVISED	
DATE	BY

CARROLL COUNTY, MARYLAND
 DEPARTMENT OF PUBLIC WORKS

[Signature] 4-12-94
 DIRECTOR DATE

UTILITY LOCATIONS IN
 CLOSED SECTION ROADWAYS

PLATE

57

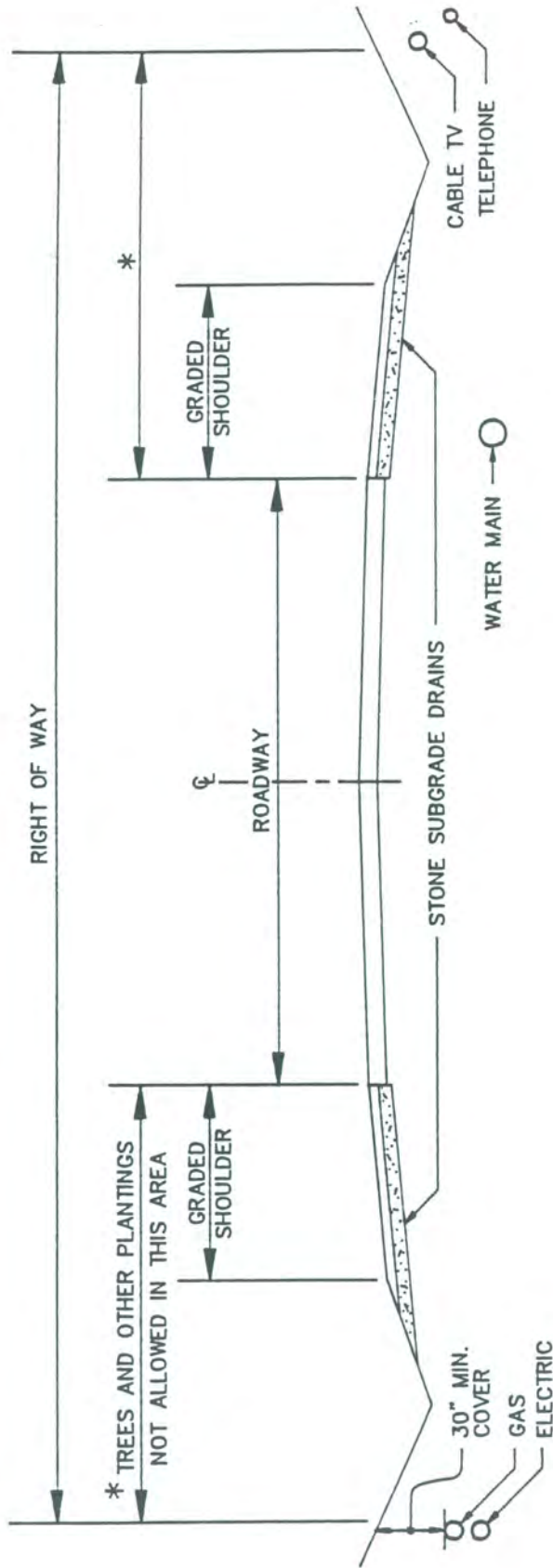

○—SANITARY SERVICE

NOTES:

1. WHERE SUBGRADE DRAINS ARE REQUIRED, UTILITIES ARE TO BE INSTALLED AS SHOWN UNLESS OTHERWISE INSTRUCTED BY THE DEPARTMENT OF PUBLIC WORKS.
2. DEPARTMENT OF PUBLIC WORKS, CONSTRUCTION INSPECTION DIVISION TO BE CONSULTED PRIOR TO INSTALLATION OF GAS, ELECTRIC, TELEPHONE, OR CABLE TV FACILITIES.
3. GAS, ELECTRIC, AND TELEPHONE UTILITIES MAY BE PLACED IN SAME TRENCH AT THE OPTION OF THE POWER COMPANY AND THE C&P TELEPHONE COMPANY.
4. ELECTRIC: 0-600V 24" COVER, OVER 600V 36" COVER.
 TELEPHONE: MAIN SERVICE 24" COVER.
 RESIDENTIAL CONNECTION 11" COVER.
 CABLE TV: 11" COVER.

CARROLL COUNTY, MARYLAND
 DEPARTMENT OF PUBLIC WORKS

[Signature] 4-12-94
 DIRECTOR DATE

UTILITY LOCATIONS IN
 OPEN SECTION ROADWAYS

REVISED	
DATE	BY

PLATE

58

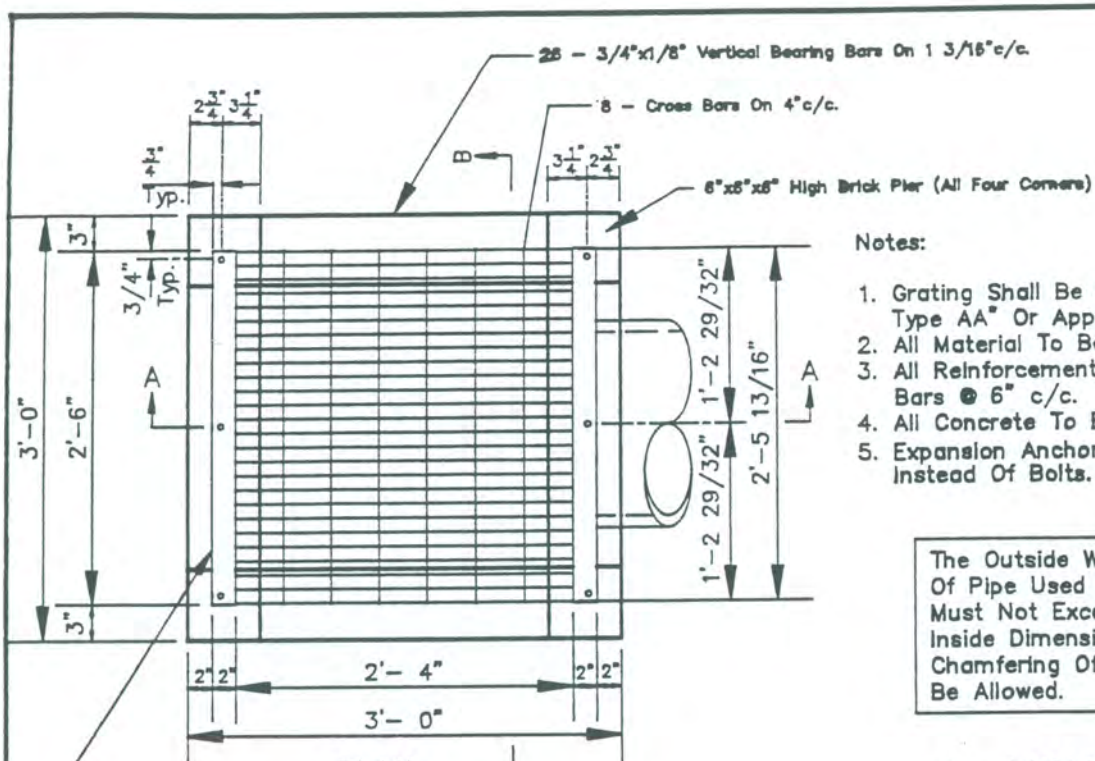

The Outside Wall Diameter Of Pipe Used With This Inlet Must Not Exceed The 2'-0" Inside Dimension Shown. Chamfering Of Walls Will Not Be Allowed.

2 - 2"x1 1/4"x3/16"x2'-6"L (Centered On Grate)
 Trim Vertical Leg Of Angle To 3/4" In Height
 Weld Securely To Grating At Every 4th Bar
 (Welded Areas To Be Touched Up With Zinc Rich Paint After Welding.)

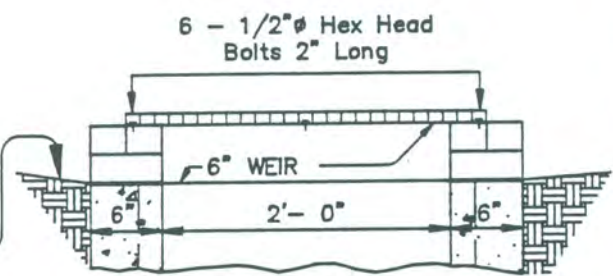

SECTION B-B

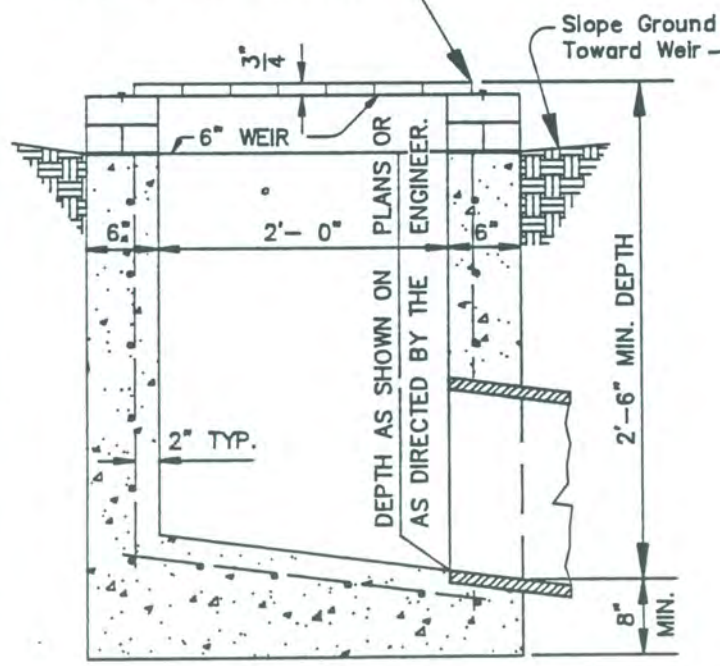

SECTION A-A

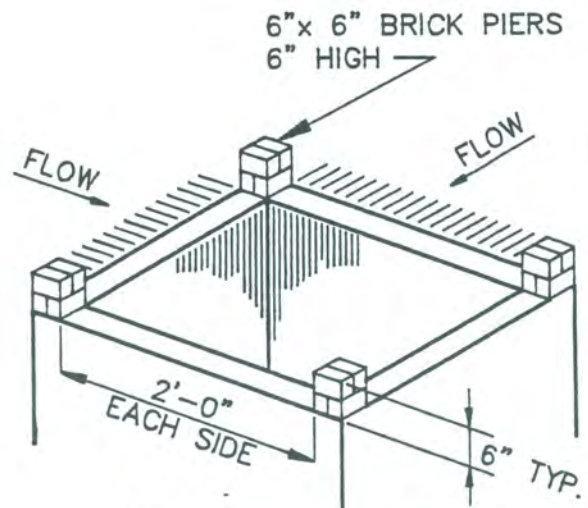

ISOMETRIC (GRATE REMOVED)

Brick Piers To Be Parged With Concrete

REVISED	
DATE	BY

CARROLL COUNTY, MARYLAND
 DEPARTMENT OF PUBLIC WORKS

[Signature] 4-12-94
 DIRECTOR DATE

MODIFIED
 STANDARD YARD INLET

PLATE

59

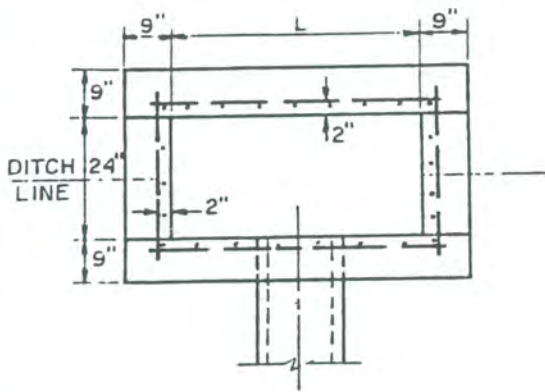

PLAN

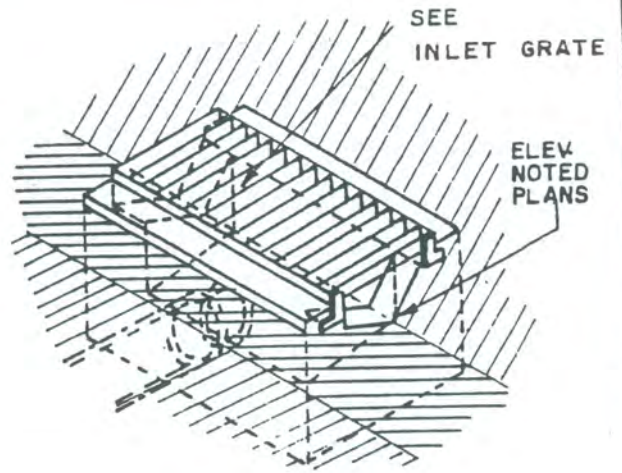

ISOMETRIC VIEW

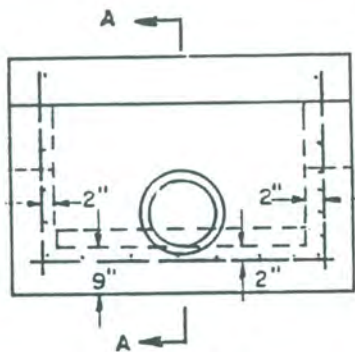

ELEVATION

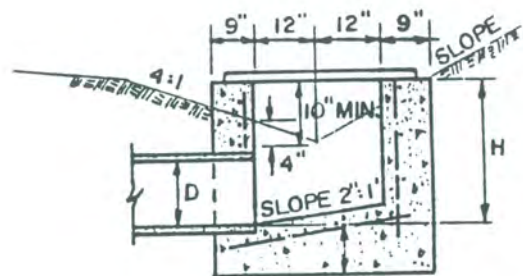

SECTION A-A

GENERAL NOTES

STEEL: VERT 4 BARS, 6" C.C.
 HOR. 4 BARS, 6" C.C.
 BOT. 4 BARS, 6" C.C.

CONCRETE: SEE GENERAL SPECIFICATIONS. HEIGHT OF FRONT & BACK WALLS MUST CONFORM TO GRADE OF ADJACENT ROAD SECTION.

BRICK MAY ONLY BE USED WITH CARROLL COUNTY DEPT. OF PUBLIC WORKS APPROVAL.

NOTE 1. DEPTH OF INLET SHALL BE INCREASED AS REQUIRED TO ACCOMMODATE PIPE GRADE AND NOTCH ELEVATION SHOWN ON THE PLAN.

REVISED	
DATE	BY

"J" SLOPE 2:1 OR FLATTER					
OPENING DIA	AREA SQ FT	DIMENSION		TYPE OF GRATE	
		L	MIN. H		
12"	0.79	4'-0"	2'-4"	C	
15"	1.23	4'-0"	2'-7"	C	
16"	1.39	4'-0"	2'-8"	C	
18"	1.78	4'-0"	2'-10"	C	
21"	2.41	5'-0"	3'-2"	E	
24"	3.14	5'-0"	3'-5"	E	
27"	3.98	6'-0"	3'-8"	G	
30"	4.91	6'-0"	4'-0"	G	
33"	5.94	6'-0"	4'-3"	G	
36"	7.07	6'-0"	4'-6"	G	

CARROLL COUNTY, MARYLAND
 DEPARTMENT OF PUBLIC WORKS

[Signature] 4-12-94
 DIRECTOR DATE

MODIFIED "J" INLET

PLATE

60

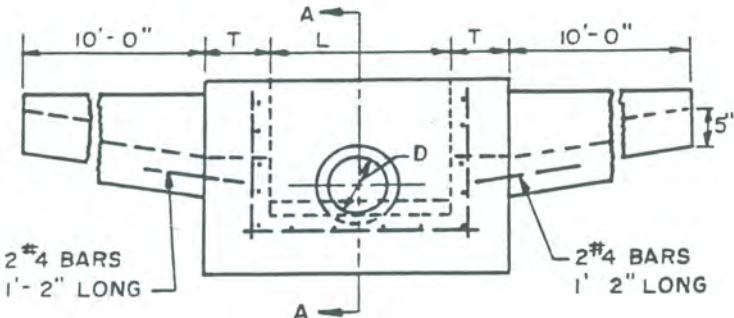

ELEVATION

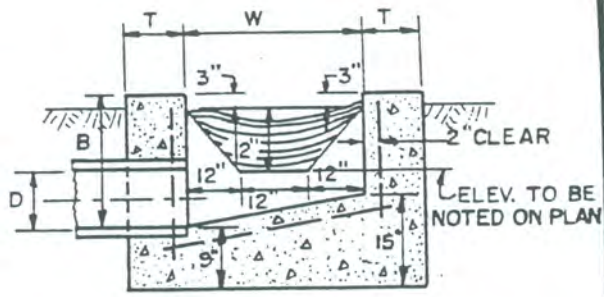

SECTION A A

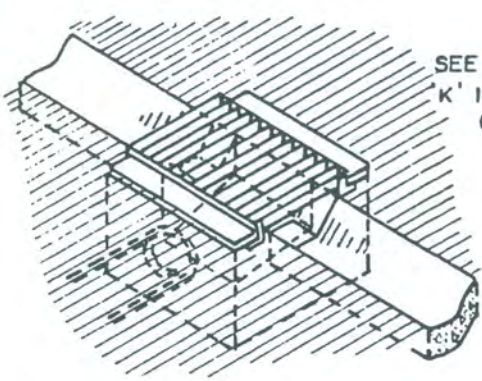

SEE STANDARD
K' INLET
GRATE.

ISOMETRIC VIEW

"K"						
OPENING		DIMENSIONS				
DIAM. D	AREA SQ.FT.	L	W	MIN. B	T	TYPE OF GRATE
12"	0.79	3'-0"	3'-0"	2'-3"	9"	A
15"	1.23	3'-0"	3'-0"	2'-6"	9"	
18"	1.78	3'-0"	3'-0"	2'-9"	9"	
24"	3.14	3'-0"	3'-0"	3'-3"	12"	B
30"	4.91	3'-6"	3'-0"	3'-9"	12"	C
36"	7.07	4'-0"	3'-0"	4'-3"	12"	D
42"	9.62	4'-6"	3'-0"	4'-9"	12"	E
48"	12.57	5'-0"	3'-0"	5'-3"	12"	F

CONSTRUCT WITH REINFORCED CONCRETE. THIS INLET MAY ONLY BE USED WITH PRIOR APPROVAL FROM THE D.P.W.

GENERAL NOTES

- STEEL #4 BARS 6" C.C. - VERTICAL
- #4 BARS 6" C.C. - HORIZONTAL
- #4 BARS 6" C.C. - BOTTOM

CONCRETE - S.H.A. MIX NO. 2

NOTES:

1. THE CONCRETE VALLEY GUTTER TO BE USED IN CONNECTION WITH THIS INLET, WILL BE WARPED FROM THE STANDARD SECTION TO MEET THE SECTION AT THE END OF THE INLET. THIS TRANSITION WILL TAKE PLACE WITHIN A DISTANCE OF TEN (10) FEET FROM THE INLET.
2. PIPE OUTLETS AND GUTTER APPROACHES CAN BE REVISED TO MEET EXISTING CONDITIONS.
3. DEPTH OF INLET SHALL BE INCREASED AS REQUIRED TO ACCOMMODATE PIPE GRADE AND NOTCH ELEVATION SHOWN ON THE PLAN.
4. THIS INLET SHALL NOT BE USED WITHOUT MODIFICATION FOR PIPES OVER 36" IN END OF INLET.
5. THROUGH INLETS SHALL HAVE BRICK CHANNELIZATION AS ON PLATE 90. SUCH INLETS NOT TO BE USED WITHOUT MODIFICATION FOR PIPES OVER 24".

CARROLL COUNTY, MARYLAND
DEPARTMENT OF PUBLIC WORKS

W. St. ... 4-12-94
DIRECTOR DATE

"K" INLET

PLATE

61

Note: The Concrete Median Ditch To Be Used In Connection With This Inlet, Will Be Warped From The Standard Section To Meet The Section At The End Of The Inlet. This Transition Will Take Place Within A Distance Of Ten (10) Feet From The Inlet.

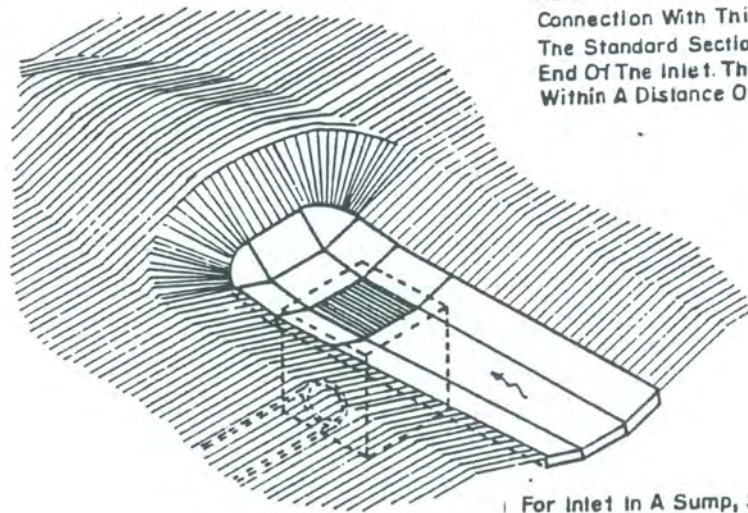

ISOMETRIC VIEW

For Inlet In A Sump, See Gutter Details As Shown In The Isometric View On Plate No. 63

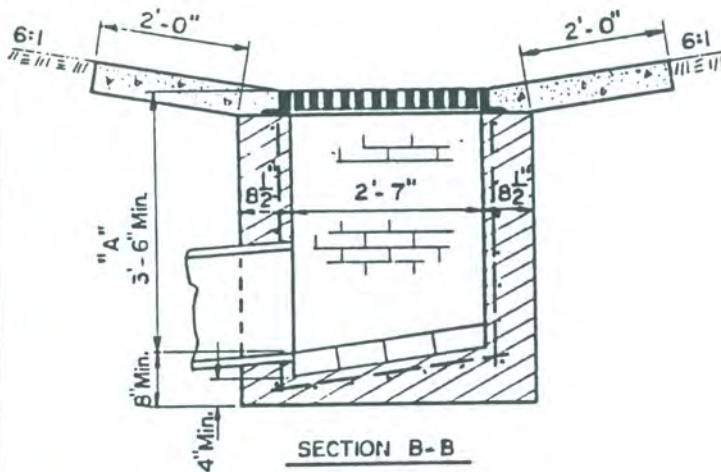

SECTION B-B

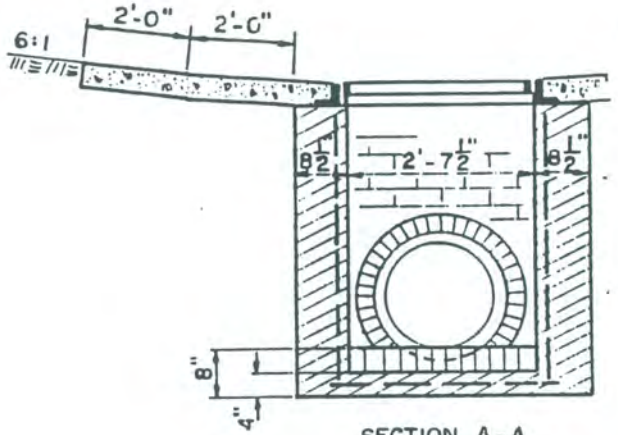

SECTION A-A

1. INLET TO BE CONSTRUCTED OF REINFORCED CONCRETE. SIZE, TYPE AND DIRECTION OF INLET CONNECTION WILL VARY TO SUIT CONDITIONS.
2. TOP 4" OF WALLS MAY BE BRICK MASONRY. ADDITIONAL BRICK MAY BE USED TO BRING THE GRATE TO GRADE IF REQUIRED.
3. GRATE STANDARD SHA 379.02
4. "BRICK FOR MASONRY," TO COMPLY WITH THE LATEST SPECIFICATIONS. REINFORCEMENT: NO. 4 \emptyset DEFORMED BARS AT 6" c/c 2" COVER.
5. REINFORCEMENT REQUIRED ON OUTSIDE, AS WELL AS ON INSIDE OF WALLS BELOW 7'-0" WHEN "A" IS GREATER THAN 7'-0" SPACING, SAME AS FOR INSIDE OF WALL.
6. INVERT MAY BE PLAIN CONCRETE OR 4" BRICK LAID ON EDGE. INVERT TO SLOPE DOWN TOWARD OUTLET AT THE RATE OF TWO (2) INCHES PER FOOT, OR AS DIRECTED.
7. BRICK FOR CONSTRUCTION OF INLET MAY BE USED IF AUTHORIZED BY DEPT. OF PUBLIC WORKS.

REVISED	
DATE	BY

CARROLL COUNTY, MARYLAND
DEPARTMENT OF PUBLIC WORKS

STANDARD TYPE K INLET
SINGLE GRATE

PLATE

K. D. C. ... 4-12-44
DIRECTOR DATE

62

NOTE: The Concrete Median Ditch To Be Used In Connection With This Inlet, Will Be Warped From The Standard Section To Meet The Section At The End Of The Inlet. This Transition Will Take Place Within A Distance Of Ten (10) Feet From The Inlet.

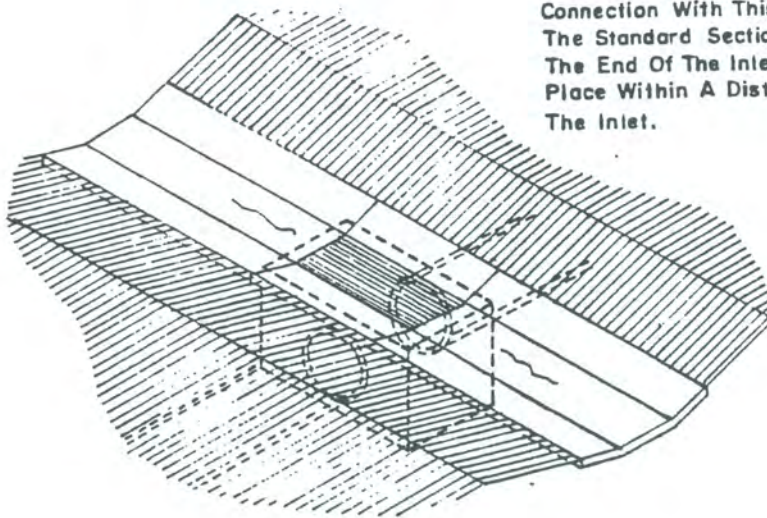

ISOMETRIC VIEW

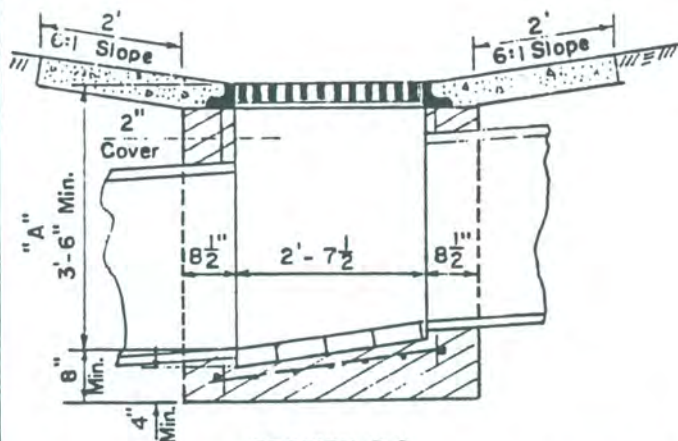

SECTION B-B

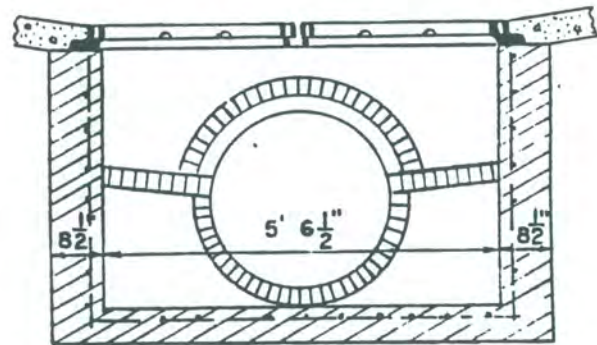

SECTION A-A

GENERAL NOTES

1. Inlet Shall Be Constructed Of S.H.A. Mix No. 2 Reinforced Concrete. Size And Type And Direction Of Inlet Construction Will Vary To Suit Conditions.
2. Top 4" Of Walls May Be Brick Masonry. Additional Brick May Be Used To Bring The Grate To Grade If Required, See Latest Specifications.
3. "Brick For Masonry," To Comply With The Latest S.H.A. Specifications. Reinforcement: No. 4 \emptyset Deformed Bars At 6" o/c, 2" Cover.
4. Reinforcement Required On Outside, As Well As On Inside Walls Below 7'-0". When "A" Is Greater Than 7'-0". Spacing Same As For Inside Of Wall.
5. Invert May Be Plain Concrete Or 4" Brick Laid On Edge Invert Of Slope. Down Toward Outlet At The Rate Of Two (2) Inches Per Foot Or As Directed.
6. Brick for Construction Of Inlet May Only Be Used If Authorized By Dept. Of Public Works.
7. Grate to be SHA Standard 379.05.

REVISED	
DATE	BY

CARROLL COUNTY, MARYLAND
DEPARTMENT OF PUBLIC WORKS

K. D. ... 4-12-94
DIRECTOR DATE

STANDARD TYPE K INLET
DOUBLE GRATE TANDEM

PLATE

63

4 ANGULAR STEEL STRAPS BOLTED TO OUTSIDE BARS OF GRATING PRIOR TO SHIPPING.

LONGITUDINAL DIRECTION OF GRATING

END OR BINDING BARS

4 ANGLE CLIPS \angle 2" x 2" x 3/16" x 2 1/2" WELDED TO BOTTOM OF GRATING.

9/16" SLOTTED HOLE TO RECEIVE 1/2" x 4" MACHINE BOLT (GALV.) IMBEDDED 3" IN CONC. WALL. NUT TO BE PLACED ON END OF BOLT AFTER GRATE IS INSTALLED

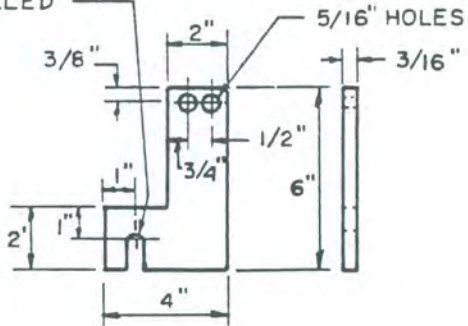

END STRAP DETAIL

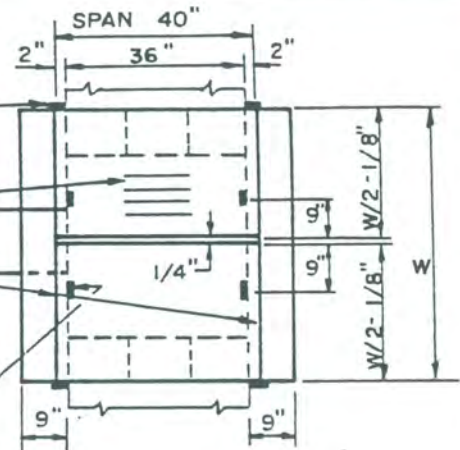

PLAN

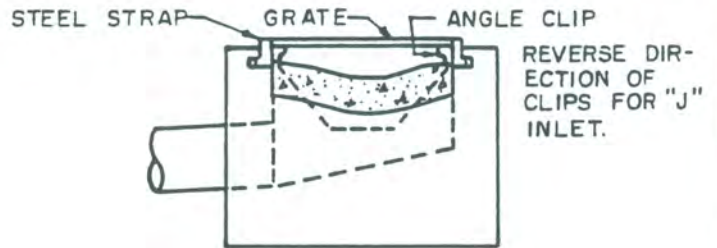

END ELEVATION

ALL MATERIAL TO BE HOT DIPPED GALVANIZED AFTER FABRICATION

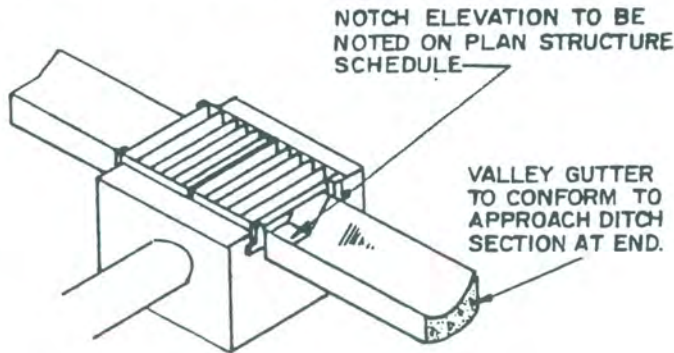

ISOMETRIC VIEW

GRATINGS ARE SUBJECT TO APPROVAL FOR EACH JOB. ANY TYPE OF SUBSTANTIAL TRANSVERSE BARS MAY BE USED WHICH WILL SUPPORT A MINIMUM UNIFORM LOAD OF 150 LBS/SQ.FT. THE TRANSVERSE BARS SHALL BE HELD RIGID BY SPACER BARS. MAXIMUM BAR SPACING SHALL BE 3"

	GRATE	SPAN	PIPE SIZE	
			K' INLET	J' INLET
54" WIDE	X	40" SPAN	12" - 18"	
60" WIDE	X	40" SPAN	21" & 24"	
66" WIDE	X	40" SPAN	27" & 30"	12" - 18"
72" WIDE	X	40" SPAN	33" & 36"	
78" WIDE	X	40" SPAN	42"	21" & 24"
84" WIDE	X	40" SPAN	48"	
90" WIDE	X	40" SPAN		27" - 36"

CARROLL COUNTY, MARYLAND DEPARTMENT OF PUBLIC WORKS

[Signature] 4-12-94
DIRECTOR DATE

STANDARD NON-TRAFFIC GRATES FOR "J" & "K" INLETS

PLATE

64

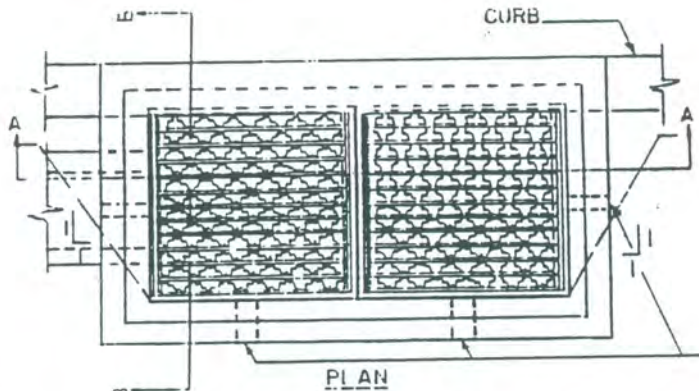

INVERT MAY BE PLAIN CONCRETE OR 4" BRICK LAID ON EDGE INVERT TO SLOPE DOWN TOWARD OUTLET AT THE RATE OF 2" PER FOOT, OR AS DIRECTED.

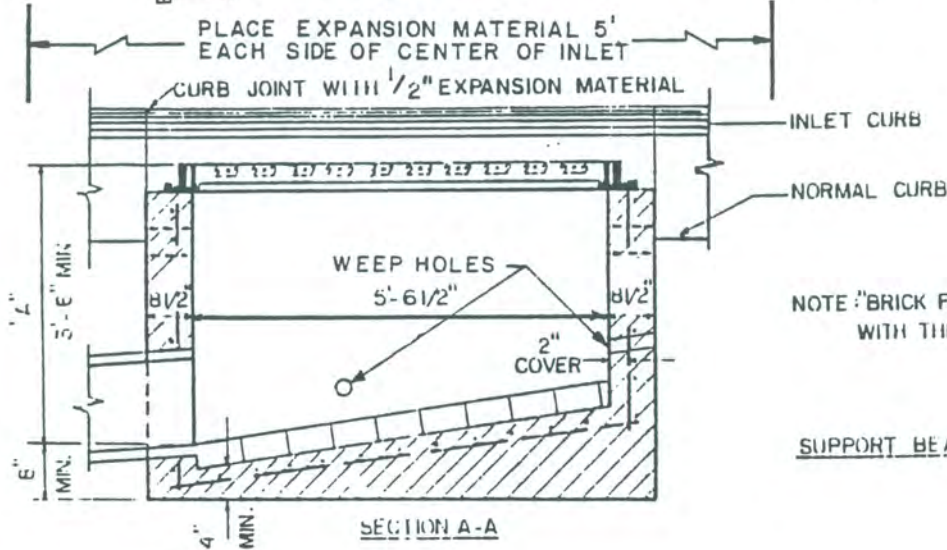

LEAVE 4" X 4" OPENING FOR SUBGRADE DRAINAGE, IF DIRECTED.

NOTE: "BRICK FOR MASONRY" TO COMPLY WITH THE LATEST SPECIFICATIONS.

SUPPORT BEAM IS NOT TO BE USED

GENERAL NOTES

1. INLET SHALL BE CONSTRUCTED OF REINFORCED CONCRETE. SIZE, TYPE, AND DIRECTION OF INLET WILL VARY TO SUIT CONDITIONS.
2. TOP 4" OF WALLS MAY BE BRICK MASONRY. ADDITIONAL BRICK MAY BE USED TO BRING THE GRATE TO GRADE IF REQUIRED. SEE LATEST SPECIFICATIONS FOR INLETS.
3. REINFORCEMENT REQUIRED ON OUTSIDE AS WELL AS ON INSIDE OF WALLS BELOW 7'-0" WHEN "A" IS GREATER THAN 7'-0" SPACING, SAME AS FOR INSIDE OF WALL.
4. PLACE 1/2" EXPANSION MATERIAL OF SAME TYPE APPROVED FOR PAVEMENT (SEE SECTION A-A).
5. THE ENTIRE INLET EXCAVATION TO BE BACK FILLED WITH CLEAN COMPACTED NO. 57 STONE AGGREGATE COMPLETELY TO SUBGRADE.
6. WEEP HOLES TO BE COVERED WITH STAINLESS STEEL OR GALVANIZED WIRE MESH.
7. FOOTERS CAN BE 4" MIN. CONCRETE BUILT TO ALLOW FOR A 4" BRICK INVERT OR ALL CONCRETE
8. FLARE CURB GUTTER AT INLET AT 1:1 MEET FRONT OF FRAME. SEE PLAN VIEW.
9. BRICK FOR CONSTRUCTION OF INLET MAY ONLY BE USED IF AUTHORIZED BY DEPT. OF PUBLIC WORKS.

NORMAL CURB LINE

REINFORCEMENT:
"4 (1/2") DEFORMED BARS
AT 6" C. TO C. 2" COVER.

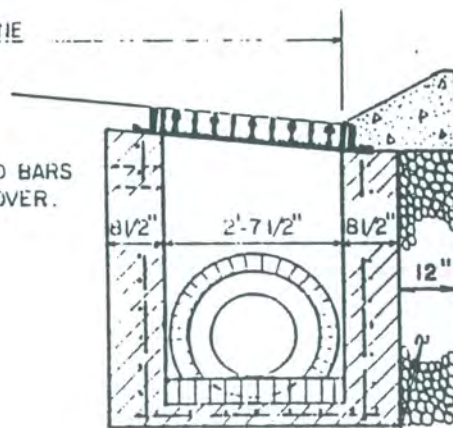

SECTION B-B

WEEP HOLES
LEAVE 2" X 2" OPENING
6" ABOVE R. MINIMUM 2
REQUIRED.

NO. 57
AGGREGATE
ALL SIDES

REVISED	
DATE	BY

CARROLL COUNTY, MARYLAND
DEPARTMENT OF PUBLIC WORKS

Handwritten signature 4-12-94
DIRECTOR DATE

STANDARD TYPE S INLET
DOUBLE GRATE TANDEM

PLATE

65

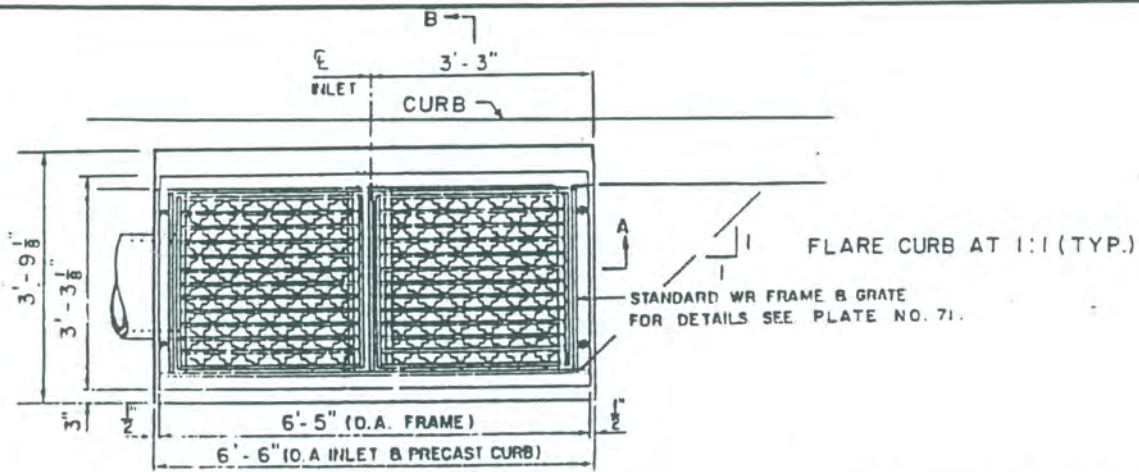

PLAN
 5'-0" INLET
 5'-0" INLET
 PLACEMENT OF 1/2" EXPANSION MATERIAL IN CURB AREA OF INLET. 5' EITHER SIDE OF INLET.

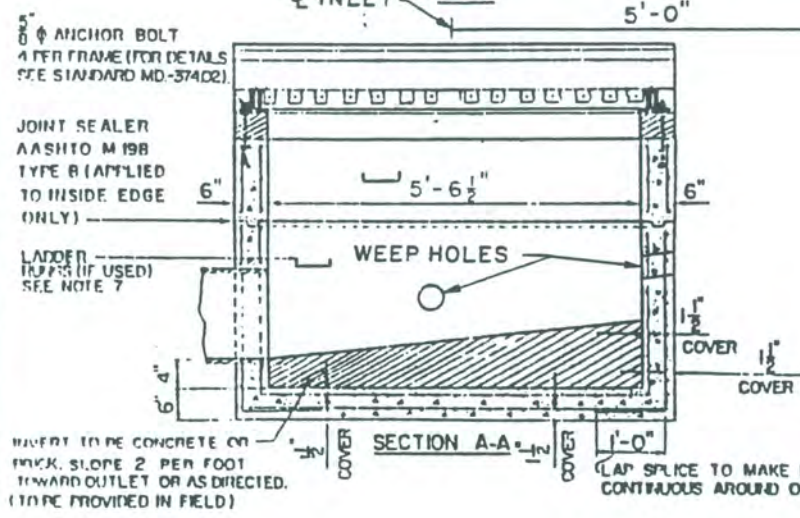

5" ANCHOR BOLT
 4 PER FRAME (FOR DETAILS SEE STANDARD MD-37402)
 JOINT SEALER
 AASHTO M 198
 TYPE B (APPLIED TO INSIDE EDGE ONLY)
 LADDER TRAPS (IF USED) SEE NOTE 7
 INVERT TO BE CONCRETE OR BRICK. SLOPE 2 PER FOOT TOWARD OUTLET OR AS DIRECTED. (TO BE PROVIDED IN FIELD)

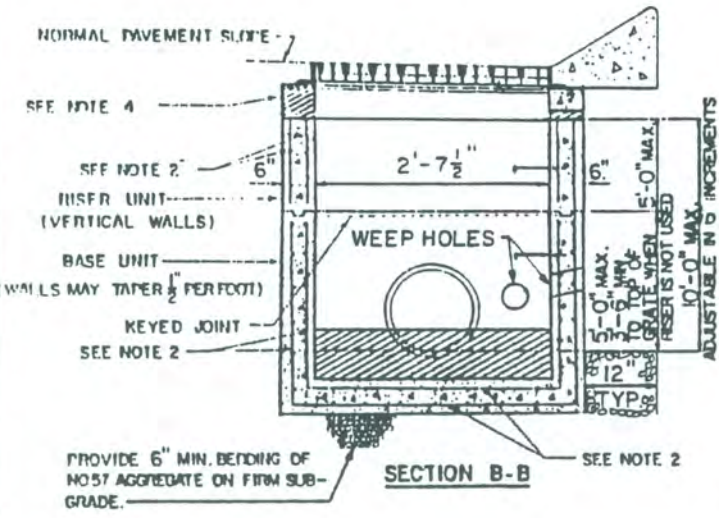

- GENERAL NOTES**
1. CONCRETE TO BE MIX NO 6 (4500PSI).
 2. REINFORCING-2 LAYERS OF 4X4-W 4.0 X W 4.0 WELDED WIRE FABRIC
 3. THREADED PLASTIC INSERTS TO BE PROVIDED FOR HANDLING
 4. GRADE AND SLOPE ADJUSTMENTS COMPLETED IN THE FIELD USING CONCRETE MIX NO 6 OR BRICK AND MORTAR.
 5. PIPE OPENINGS TO BE PROVIDED AS REQUIRED FOR SIZE, LOCATION AND INVERT ELEVATIONS REFER TO CONSTRUCTION PLANS.
 6. PLACEMENT OF SUBGRADE DRAINAGE WILL BE AS DIRECTED BY THE ENGINEER OR AS NOTED ON THE CONSTRUCTION PLANS.
 7. LADDER RUNGS SHALL BE IN ACCORDANCE WITH STANDARD MD-383.91 AND MD-383.92 OR AS DIRECTED BY THE ENGINEER.
 8. MINIMUM DEPTH PAYMENT PER "EACH" INLET INCLUDES DEPTHS UP TO 3'-6". VERTICAL DEPTH PAYMENT PER LINEAR FOOT FOR DEPTHS IN EXCESS OF 3'-6".
 9. A 6" PERFORATED CIRCULAR PIPE, FOR EROSION AND SEDIMENT CONTROL, SHALL BE PLACED IN THE INLET WALL AT ALL INLET SEDIMENT TRAPS AS SHOWN ON THE PLANS.
 10. MINIMUM OF 2 WEEP HOLES TO BE CAST IN BASE UNIT 6" ABOVE FLOW LINE - PVC MAY BE USED (2" MIN. DIAMETER) - COVER OUTSIDE W/ STAINLESS STEEL OR GALVANIZED WIRE CLOTH.

REVISED	
DATE	BY

CARROLL COUNTY, MARYLAND
 DEPARTMENT OF PUBLIC WORKS
Frank S. ... 4-12-94
 DIRECTOR DATE

PRECAST
 STANDARD TYPE S INLET
 DOUBLE GRATE TANDEM

PLATE
 66

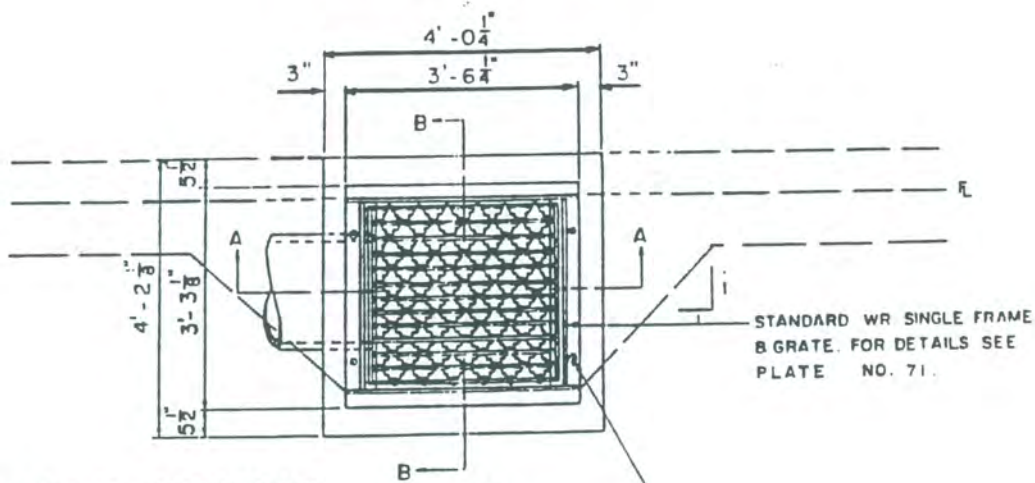

PLACEMENT OF 1/2" EXPANSION MATERIAL IN CURB AREA OF INLET

PLAN

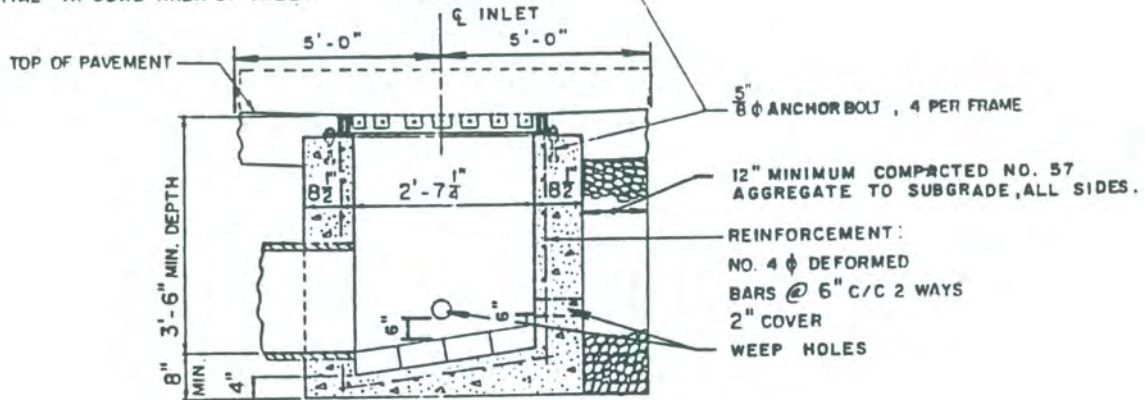

SECTION A-A

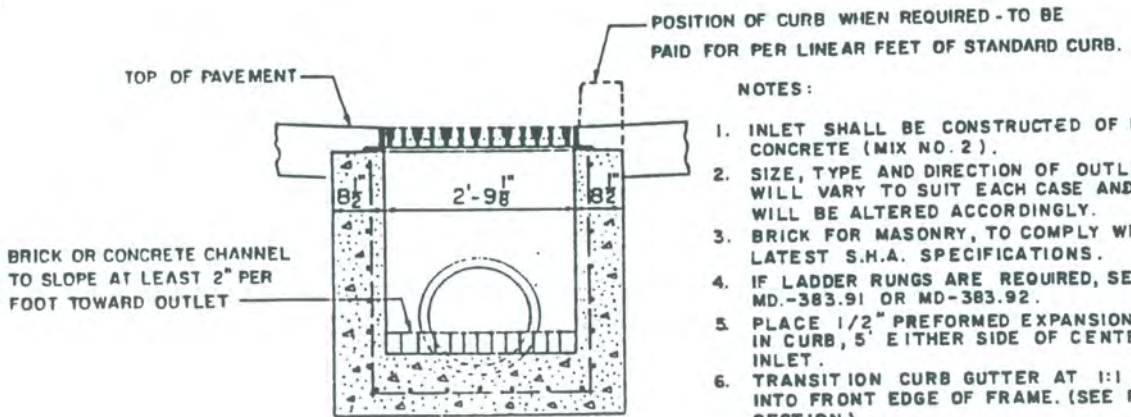

SECTION B-B

NOTES:

1. INLET SHALL BE CONSTRUCTED OF REINFORCED CONCRETE (MIX NO. 2).
2. SIZE, TYPE AND DIRECTION OF OUTLET PIPE WILL VARY TO SUIT EACH CASE AND THE INV. WILL BE ALTERED ACCORDINGLY.
3. BRICK FOR MASONRY, TO COMPLY WITH THE LATEST S.H.A. SPECIFICATIONS.
4. IF LADDER RUNGS ARE REQUIRED, SEE STANDARD MD.-383.91 OR MD-383.92.
5. PLACE 1/2" PREFORMED EXPANSION MATERIAL IN CURB, 5' EITHER SIDE OF CENTERLINE INLET.
6. TRANSITION CURB GUTTER AT 1:1 TO TIE INTO FRONT EDGE OF FRAME. (SEE PLAN SECTION)
7. BRICK FOR CONSTRUCTION OF INLET MAY ONLY BE USED IF AUTHORIZED BY DEPT. OF PUBLIC WORKS.

REVISED	
DATE	BY

CARROLL COUNTY, MARYLAND
DEPARTMENT OF PUBLIC WORKS

Karl Kinsler 4-12-44
DIRECTOR DATE

SINGLE WR INLET

PLATE

67

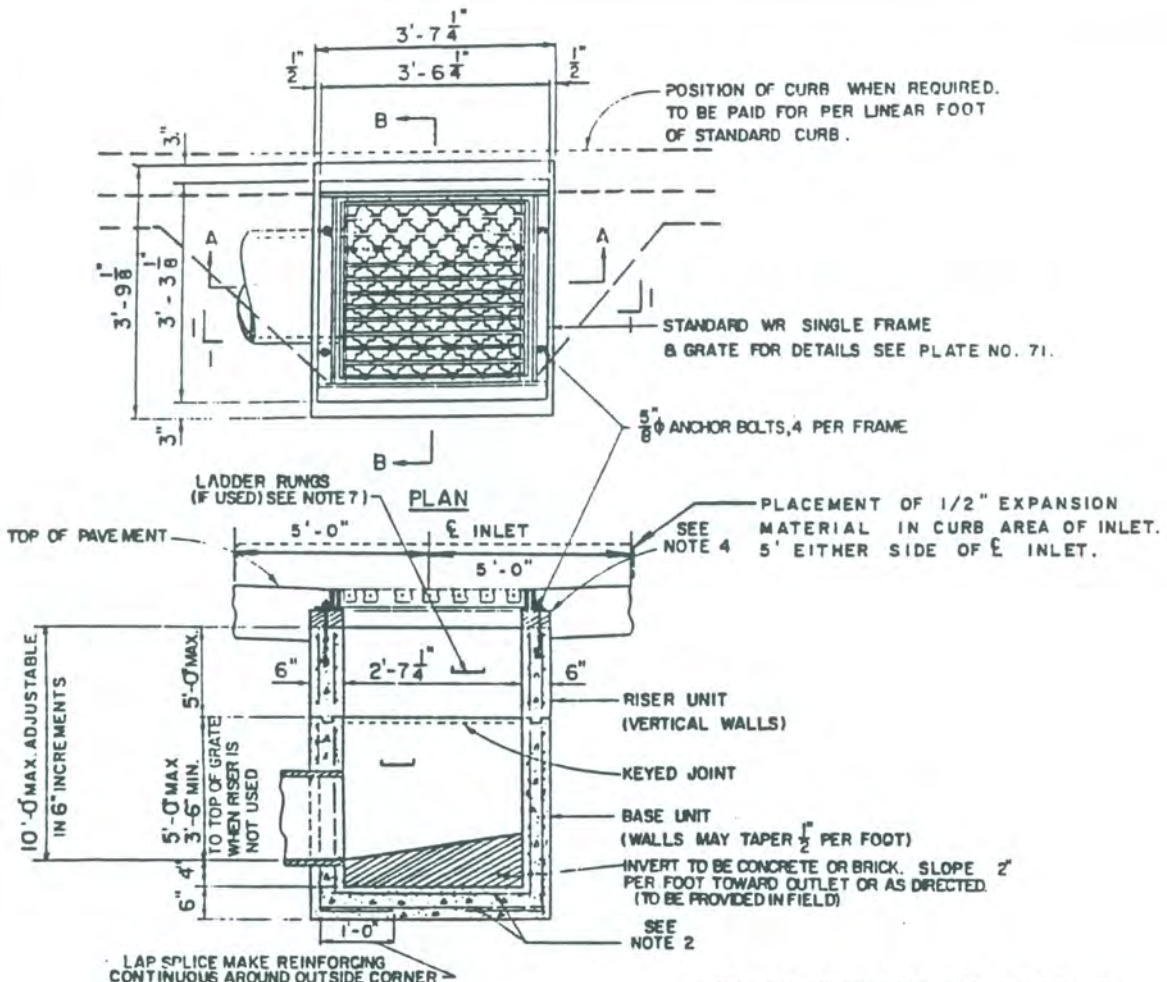

POSITION OF CURB WHEN REQUIRED. TO BE PAID FOR PER LINEAR FOOT OF STANDARD CURB.

STANDARD WR SINGLE FRAME & GRATE FOR DETAILS SEE PLATE NO. 71.

5/8" ANCHOR BOLTS, 4 PER FRAME

PLACEMENT OF 1/2" EXPANSION MATERIAL IN CURB AREA OF INLET. 5' EITHER SIDE OF INLET.

10'-0" MAX. ADJUSTABLE IN 6" INCREMENTS
5'-0" MAX. 3'-6" MIN. WHEN RISER IS NOT USED

RISER UNIT (VERTICAL WALLS)

KEYED JOINT

BASE UNIT (WALLS MAY TAPER 1/2" PER FOOT)

INVERT TO BE CONCRETE OR BRICK. SLOPE 2" PER FOOT TOWARD OUTLET OR AS DIRECTED. (TO BE PROVIDED IN FIELD)

SEE NOTE 2

LAP SPlice MAKE REINFORCING CONTINUOUS AROUND OUTSIDE CORNER

NO. 57 AGGREGATE TO SUBGRADE, ALL SIDES.

GENERAL NOTES

1. CONCRETE TO BE MIX NO. 6 (4500PSI).
2. REINFORCING-2 LAYERS OF 4X4-W 40 X W 4.0 WELDED WIRE FABRIC.
3. THREADED PLASTIC INSERTS TO BE PROVIDED FOR HANDLING.
4. GRADE AND SLOPE ADJUSTMENTS COMPLETED IN THE FIELD USING CONCRETE MIX NO. 6 OR BRICK AND MORTAR.
5. PIPE OPENINGS TO BE PROVIDED AS REQUIRED, FOR SIZE, LOCATION AND INVERT ELEVATIONS REFER TO CONSTRUCTION PLANS.
6. PLACEMENT OF SUBGRADE DRAINAGE WILL BE AS DIRECTED BY THE ENGINEER OR AS NOTED ON THE CONSTRUCTION PLANS.
7. LADDER RUNGS SHALL BE IN ACCORDANCE WITH STANDARD MD-383.01, AND MD-383.92 OR AS DIRECTED BY THE ENGINEER.
8. MINIMUM DEPTH PAYMENT PER EACH INLET INCLUDES DEPTHS UP TO 3'-6". VERTICAL DEPTH PAYMENT PER LINEAR FOOT FOR DEPTHS IN EXCESS OF 3'-6".
9. MINIMUM OF 2 WEEP HOLES 2" MIN. DIAMETER PLACED 6" ABOVE INVERT PER BASE UNIT. COVER OUTSIDE WITH STAINLESS STEEL OR GALVANIZED WIRE MESH.
10. EXPANSION PLACED IN CURB AS DETAILED IN SECTION A-A.

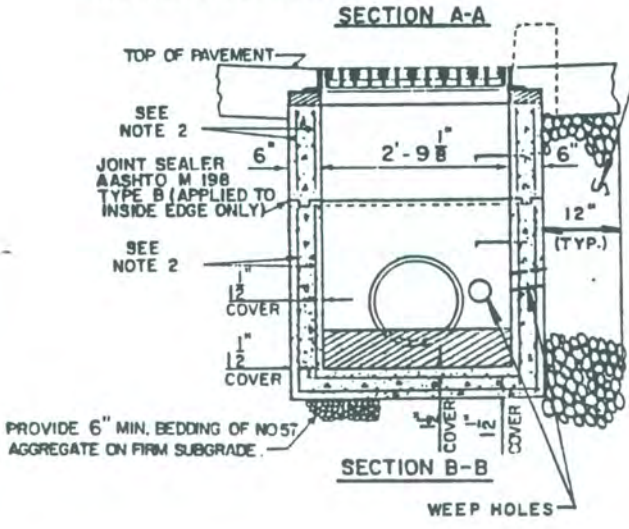

PROVIDE 6" MIN. BEDDING OF NO. 57 AGGREGATE ON FIRM SUBGRADE.

REVISED	
DATE	BY

CARROLL COUNTY, MARYLAND
DEPARTMENT OF PUBLIC WORKS
Carroll 4-12-94
DIRECTOR DATE

PRECAST
SINGLE WR INLET

PLATE
68

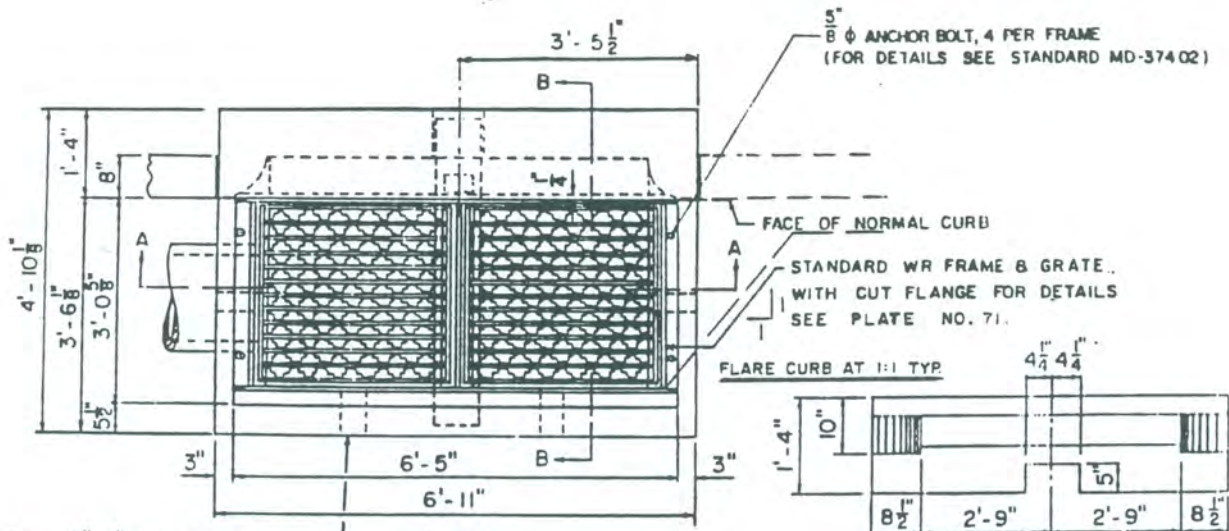

LEAVE 4"x4" OPENINGS FOR SUBGRADE DRAINAGE IF DIRECTED

CURB JOINT WITH $\frac{1}{2}$ " EXPANSION MATERIAL

TOP OF CURB

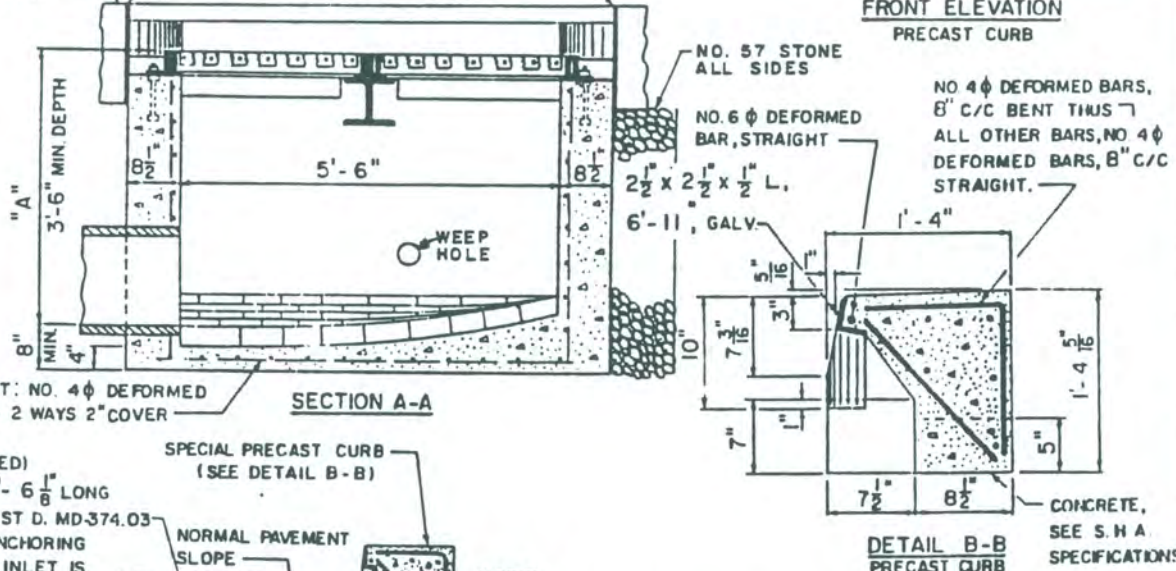
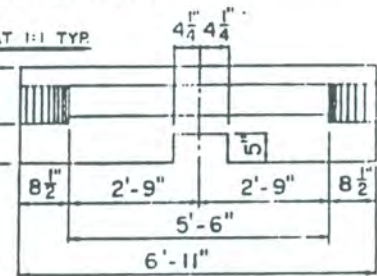

WB X 31 (GALVANIZED) SUPPORT BEAM 4'-6 $\frac{1}{8}$ " LONG FOR DETAILS SEE ST D. MD-374.03 FOR METHOD OF ANCHORING SUPPORT BEAM IF INLET IS CONSTRUCTED OF BRICK SEE STD. MD-374.05 (FOR INLET REPAIR ONLY)

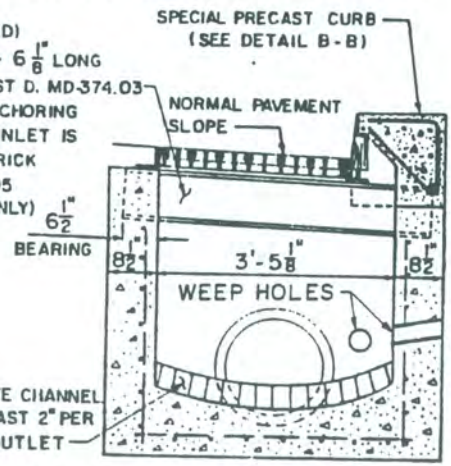

- NOTES:
1. INLET SHALL BE CONSTRUCTED OF REINFORCED CONCRETE MIX NO. 2. SIZE, TYPE, AND DIRECTION OF INLET CONNECTION WILL VARY TO SUIT CONDITIONS. SEE S.H.A. SPECIFICATION FOR INLETS.
 2. REINFORCEMENT REQUIRED ON OUTSIDE, AS WELL AS ON INSIDE, OF WALLS BELOW 7'-0" WHEN "A" IS GREATER THAN 7'-0" SPACING, SAME AS FOR INSIDE WALL.
 3. BRICK FOR MASONRY TO COMPLY WITH THE S.H.A. SPECIFICATIONS.
 4. FOR UNDEPRESSED INLETS, USE NORMAL PAVEMENT SLOPE.
 5. LADDER RUNGS ARE REQUIRED SEE STANDARD MD-383.91 OR MD-383.92.
 6. BRICK FOR CONSTRUCTION OF INLET MAY ONLY BE USED IF AUTHORIZED BY DEPARTMENT OF PUBLIC WORKS.
 7. A 6" PERFORATED CIRCULAR PIPE, FOR EROSION AND SEDIMENT CONTROL, SHALL BE PLACED IN THE INLET WALL AT ALL INLET SEDIMENT TRAPS AS SHOWN ON THE PLANS.
 8. MINIMUM OF 2 WEEP HOLES TO BE CAST IN BASE UNIT 6" ABOVE FLOW LINE - PVC MAY BE USED (2" MIN. DIAMETER) - COVER OUTSIDE WITH STAINLESS STEEL OR GALVANIZED WIRE CLOTH.

REVISED	
DATE	BY

PLATE

69

CARROLL COUNTY, MARYLAND
DEPARTMENT OF PUBLIC WORKS

Carroll County 4-12-94
DIRECTOR DATE

STANDARD WR INLET

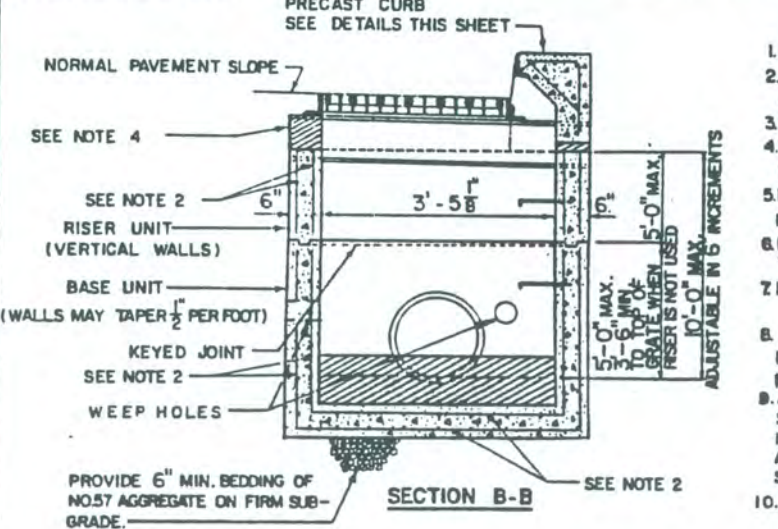
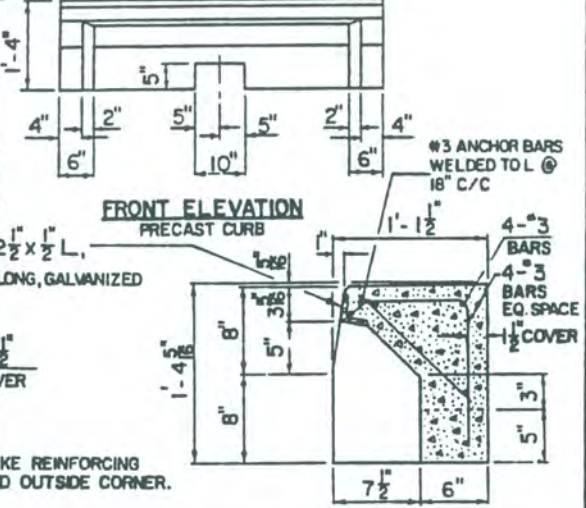
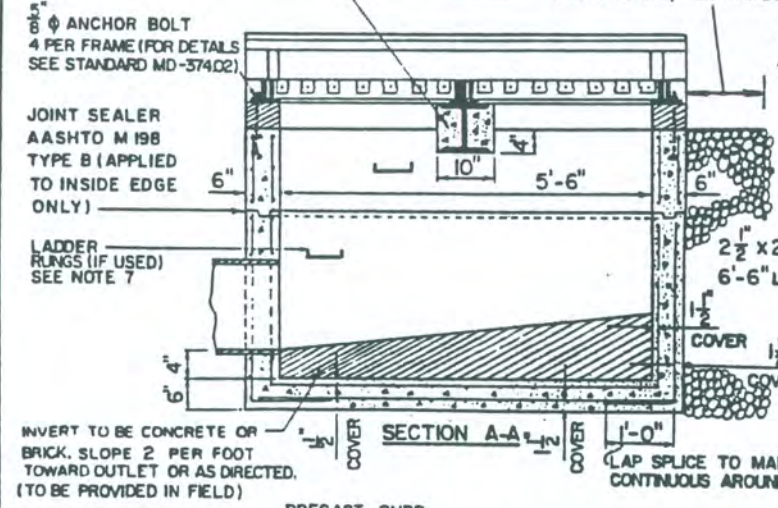
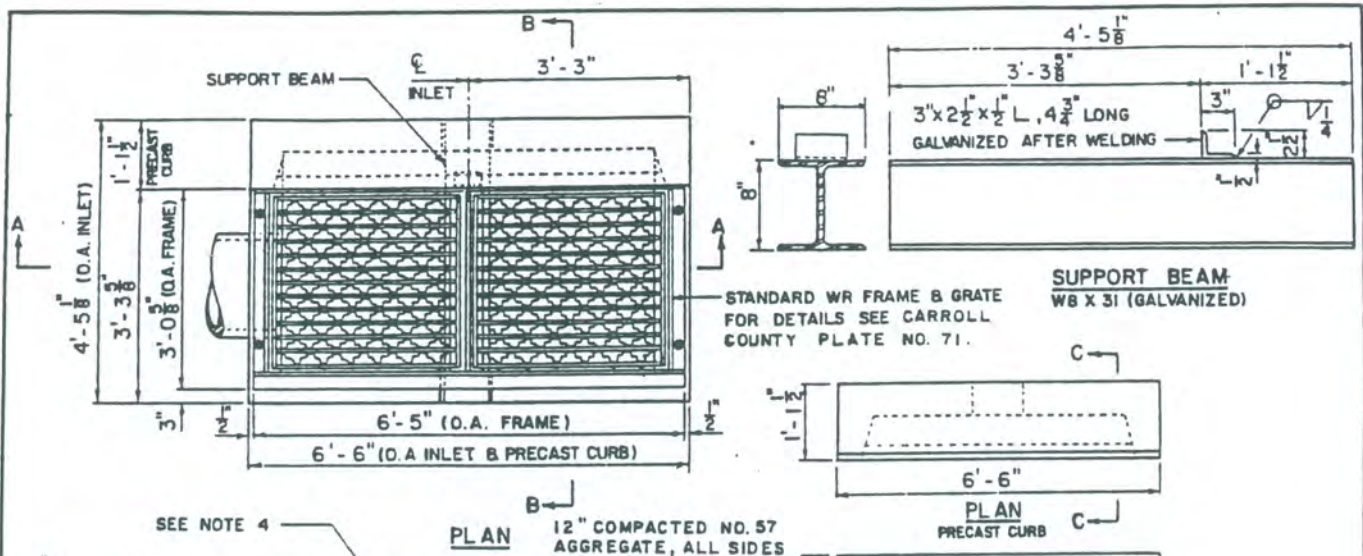

- GENERAL NOTES**
1. CONCRETE TO BE MIX NO.6 (4500PSI).
 2. REINFORCING-2 LAYERS OF 4X4-W 4.0 X W 4.0 WELDED WIRE FABRIC
 3. THREADED PLASTIC INSERTS TO BE PROVIDED FOR HANDLING.
 4. GRADE AND SLOPE ADJUSTMENTS COMPLETED IN THE FIELD USING CONCRETE MIX NO.6 OR BRICK AND MORTAR.
 5. PIPE OPENINGS TO BE PROVIDED AS REQUIRED FOR SIZE, LOCATION AND INVERT. ELEVATIONS REFER TO CONSTRUCTION PLANS.
 6. PLACEMENT OF SUBGRADE DRAINAGE WILL BE AS DIRECTED BY THE ENGINEER OR AS NOTED ON THE CONSTRUCTION PLANS.
 7. LADDER RUNGS SHALL BE IN ACCORDANCE WITH PLATE NO. OR AS DIRECTED BY THE ENGINEER.
 8. MINIMUM DEPTH PAYMENT PER "EACH" INLET INCLUDES DEPTHS UP TO 3'-6". VERTICAL DEPTH PAYMENT PER LINEAR FOOT FOR DEPTHS IN EXCESS OF 3'-6".
 9. A 6" PERFORATED CIRCULAR PIPE, FOR EROSION AND SEDIMENT CONTROL, SHALL BE PLACED IN THE INLET WALL AT ALL INLET SEDIMENT TRAPS AS SHOWN ON THE PLANS.
 10. MINIMUM OF 2 WEEP HOLES TO BE CAST IN BASE UNIT 6" ABOVE FLOW LINE - PVC MAY BE USED (2" MIN. DIAMETER) - COVER OUTSIDE W/ STAINLESS STEEL OR GALVANIZED WIRE CLOTH.

REVISED	
DATE	BY

CARROLL COUNTY, MARYLAND
 DEPARTMENT OF PUBLIC WORKS

[Signature] 4-12-94
 DIRECTOR DATE

PRECAST WR COMBINATION
 INLET

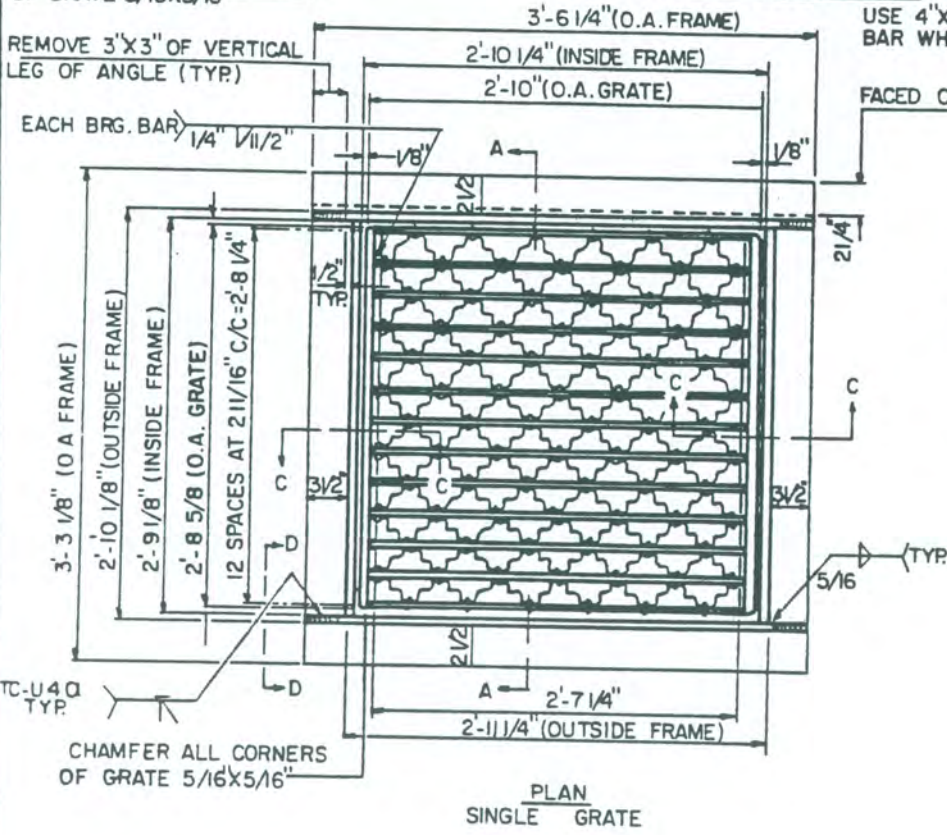
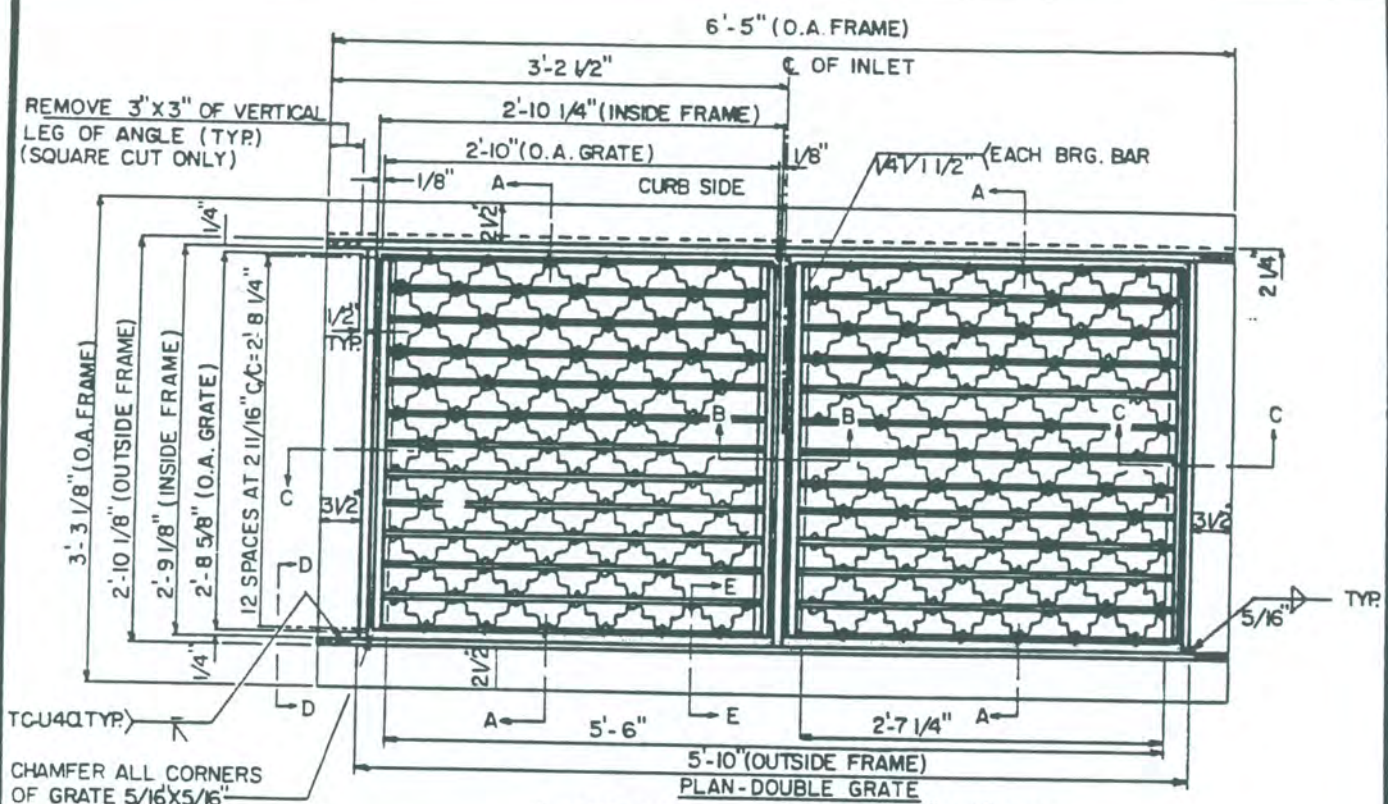

- GENERAL NOTES**
1. FRAMES & GRATES TO BE SQUARE FLAT & TRUE.
 2. STRUCTURAL STEEL SHALL BE A.S.T.M. DESIGNATION A-36.
 3. FRAMES & GRATES TO BE GALVANIZED AFTER FABRICATION IN ACCORDANCE WITH A.S.T.M. DESIGNATION A-123 EXCEPT FOR ADHERENCE WHICH SHALL BE IN ACCORDANCE WITH A.S.T.M. DESIGNATION A-153.

REVISED	
DATE	BY
PLATE	

71

CARROLL COUNTY, MARYLAND
DEPARTMENT OF PUBLIC WORKS

Carroll County 4-12-94
DIRECTOR DATE

STANDARD WR INLET
FRAME AND GRATE

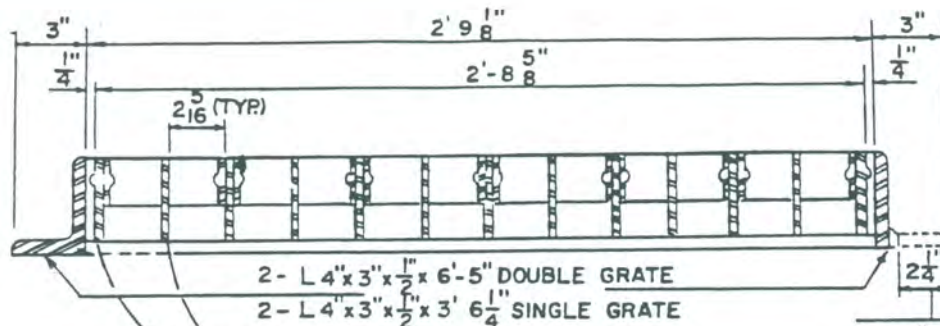

SECTION A-A

USE 4" x 1/2" FLAT BAR WHEN OPEN FACED CURB IS USED

13- 3 1/2" x 1/2" x 2'-9" Bearing Bars (Per Grate)

2- 3 1/2" x 1/2" x 2'-8 5/8" Band Bars (Per Grate)

12- 2" x 1/4" Reticular Bars (Per Grate)

3/8" ϕ Rivets (Flat Or Round Head)

@ 5" C/C In 13/32" ϕ Holes

Chamber Bottom Of Band Bars 5/16" x 5/16"

3 1/2" x 1/2" x 2'-9 1/8" Bar

3 1/2" x 1/2" x 2'-8 7/8" Bar

Bevel Both Ends

Bevel Both Ends

ζ Of Inlet

SECTION B-B

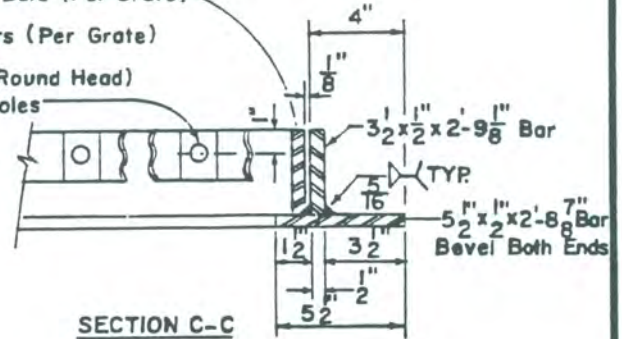

SECTION C-C

NOTE 'B' - Weld 3 1/2" x 1/2" x 2'-8 7/8" Bar To 4" x 3" x 1/2" L Before Welding 3 1/2" x 1/2" x 2'-9 1/8" Bar

NOTE 'A' - Weld 5 1/2" x 1/2" Bar To 4" x 3" x 1/2" L Before Welding 3 1/2" x 1/2" Bar

TC-U4a NOTE 'A'

5 1/2" x 1/2" x 2'-8 7/8" Bar Bevel Both Ends

SECTION D-D

TC-U4a NOTE 'B'

3 1/2" x 1/2" x 2'-8 7/8" Bar Bevel Both Ends

SECTION E-E (Shown Without Grate)

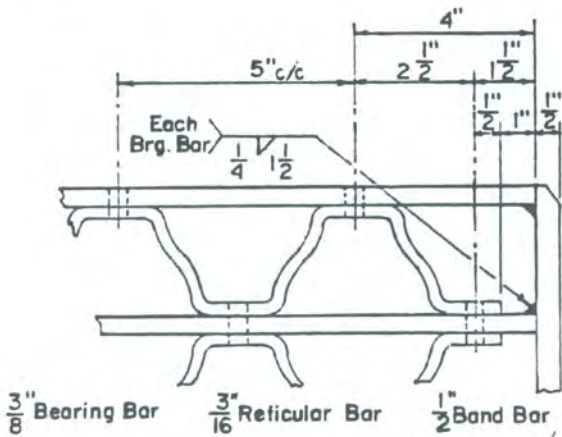

GRATING DETAIL

REVISED	
DATE	BY

PLATE

72

CARROLL COUNTY, MARYLAND DEPARTMENT OF PUBLIC WORKS

STANDARD WR INLET FRAME AND GRATE (SECTIONAL VIEW)

[Signature] 4-12-94
DIRECTOR DATE

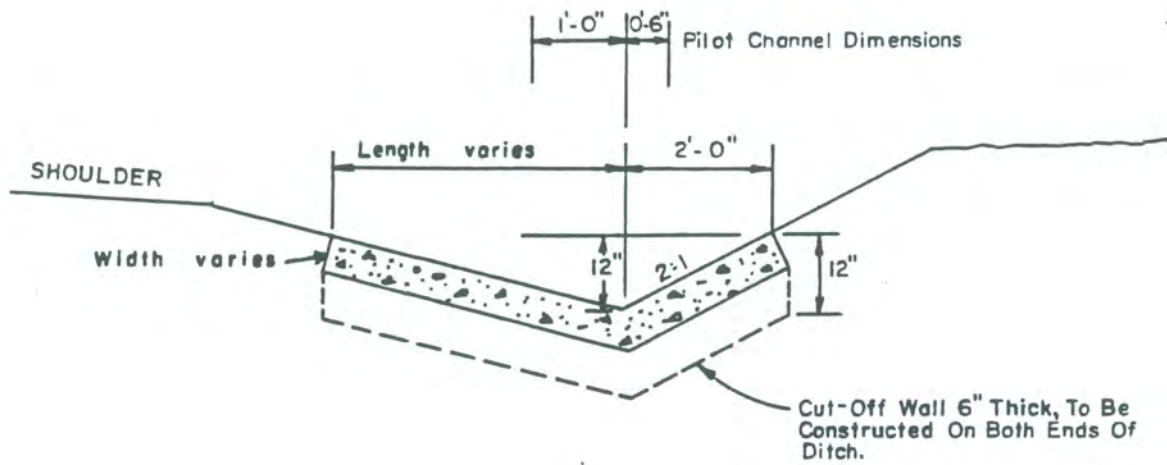

Notes:

1. Mix No. 2 Concrete.
2. Expansion Joints (1/2" Non-Extruding) 100' Maximum.
3. Contraction Joints At 10' C.C.
4. 1/4" Radius On Top Edge Of Concrete.
5. Check Walls, 6" Thick And 6" Deep, To Be Constructed To The Full Width Of The Concrete Ditch At 50' Intervals, Approximately Halfway Between Expansion Joints On Grades Of 5% Or More.

REVISED	
DATE	BY

CARROLL COUNTY, MARYLAND
DEPARTMENT OF PUBLIC WORKS

CONCRETE SIDE
DITCH

PLATE

73

[Signature] 4-12-94
DIRECTOR DATE

SAMPLE DETAIL - OUTFALL PROTECTION

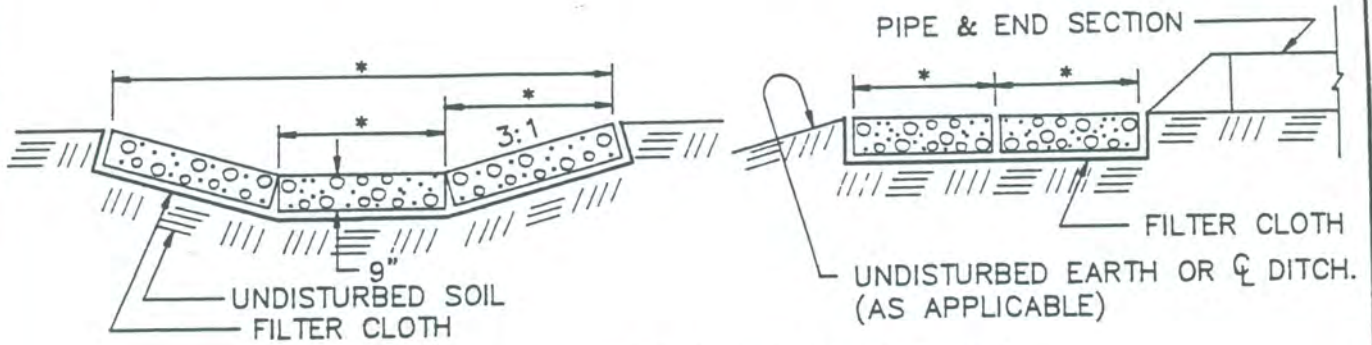

* ACTUAL DIMENSIONS SHALL BE SHOWN

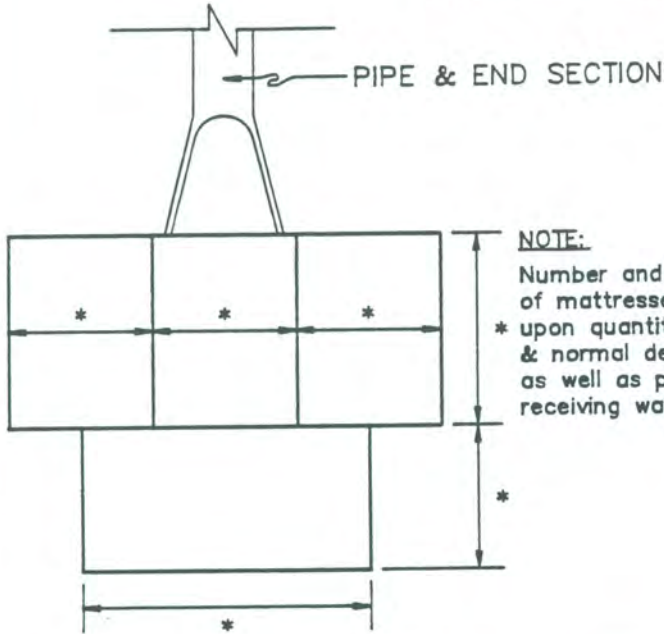

NOTE:
 Number and placement of mattresses dependent upon quantity, velocities, & normal depth of flows as well as pipe size and receiving watercourse.

GENERAL NOTES:

1. ALL MATTRESSES MUST BE PVC COATED.
2. ALL MATTRESSES SHALL BE PLACED ON FILTER CLOTH.
3. EACH INSTALLATION SHALL SHOW A LAYOUT DIAGRAM GIVING SIZE AND LOCATION OF EACH BASKET.
4. STONE SHALL BE 4"-6"(NOM.)
5. MATERIALS AND SPECIFICATIONS NOT COVERED ABOVE SHALL BE IN ACCORDANCE WITH THE MANUFACTURERS RECOMMENDATIONS.

LENGTH	WIDTH	No. of THICKNESS	No. of CELLS	AREA SQUARE YARDS	CAPACITY CUBIC YARDS
9'	6'	9"	3	6	1.5
12'	6'	9"	4	8	2

SPECIFICATIONS PVC COATED	
Mesh opening	Hex. nom. $2\frac{1}{2}$ " x $3\frac{1}{4}$ "
Wire for netting	0.0866" nom. diam. plus nom. 0.02165" PVC
Wire for selvages	0.1062" nom. diam. plus nom. 0.02165" PVC
Wire for binding	0.0866" nom. diam. plus nom. 0.02165" PVC
Zinc coating	0.70 ozs. per sq.ft. plus nom. 0.02165" PVC
Minimum thickness of PVC coating shall be not less than 0.015".	

REVISED	
DATE	BY

CARROLL COUNTY, MARYLAND
 DEPARTMENT OF PUBLIC WORKS

Keith C. ... 4-12-94
 DIRECTOR DATE

STONE OUTFALL PROTECTION

PLATE

74

When concrete paving is used wire mesh shall be extended down into cutoff wall at lower end of paving.

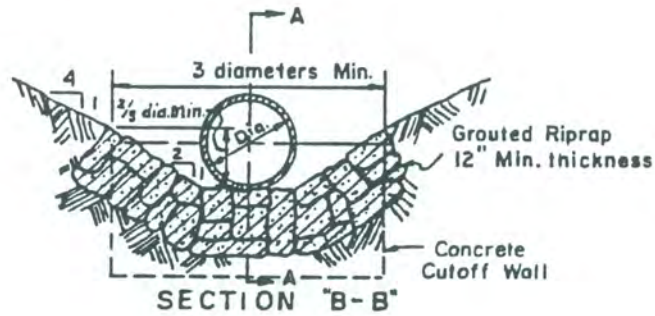
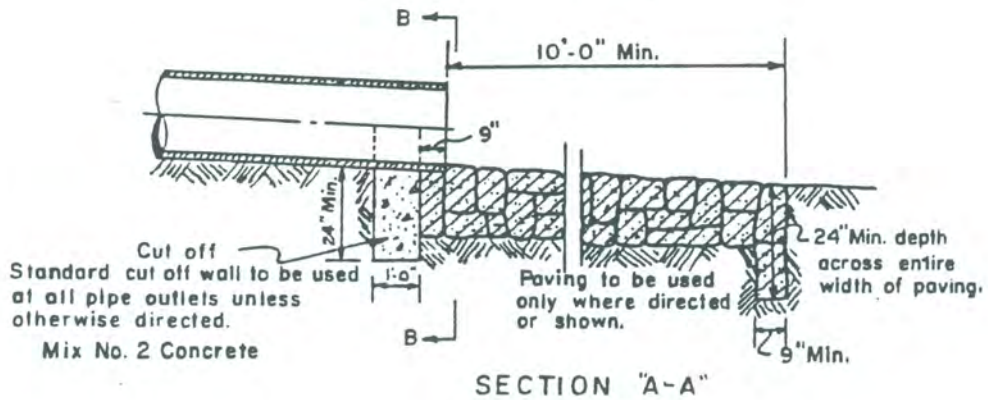

CUTOFF WALL AND RIPRAP PAVING

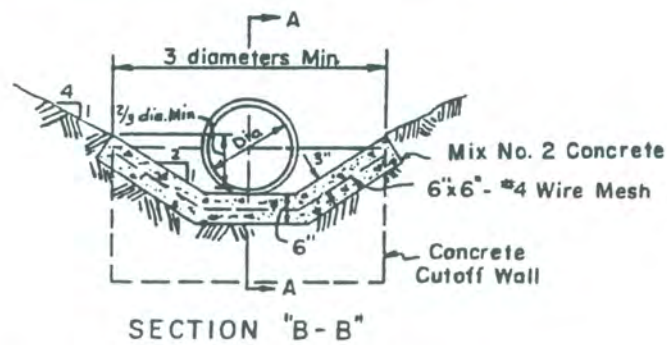

CUTOFF WALL AND CONCRETE PAVING

REVISED	
DATE	BY

CARROLL COUNTY, MARYLAND
DEPARTMENT OF PUBLIC WORKS

Carroll County 4-12-94
DIRECTOR DATE

CUTOFF WALL & PAVING

PLATE

75

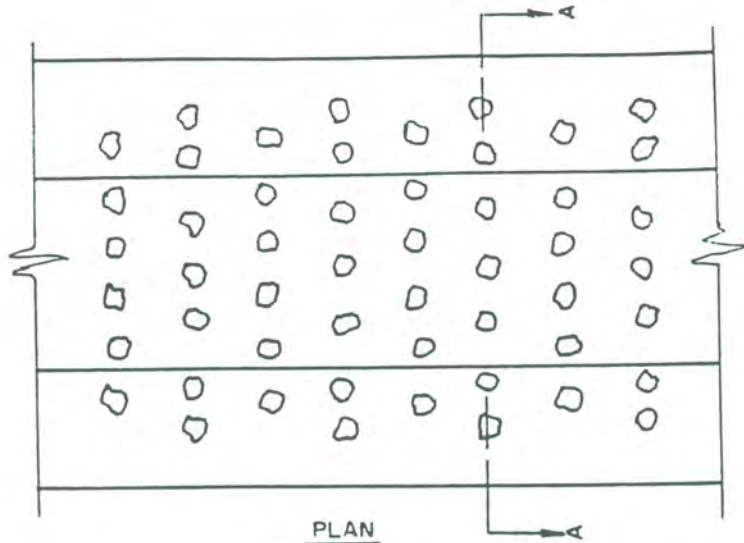

Note: Row Of Stones (As Shown Below)
 Or Pre - Cast Concrete Blocks (4" X 8" X 8")
 Shall Be 18" Apart, Stagger Alternate Rows.

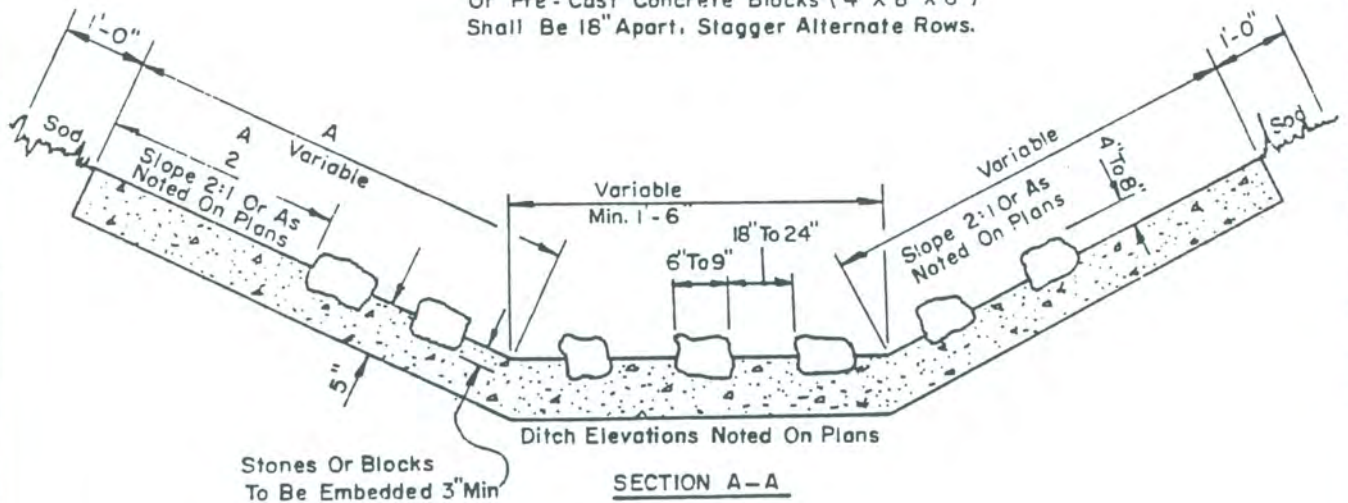

General Note:
 All Dimensions And Locations
 Not Indicated, For Items Appearing
 On This Sheet Or On The Plans,
 Shall Be Directed By The Engineer.

REVISED	
DATE	BY
PLATE	
76	

CARROLL COUNTY, MARYLAND
 DEPARTMENT OF PUBLIC WORKS
[Signature] 4-12-94

5" CONCRETE ENERGY
 DISSIPATING GUTTER

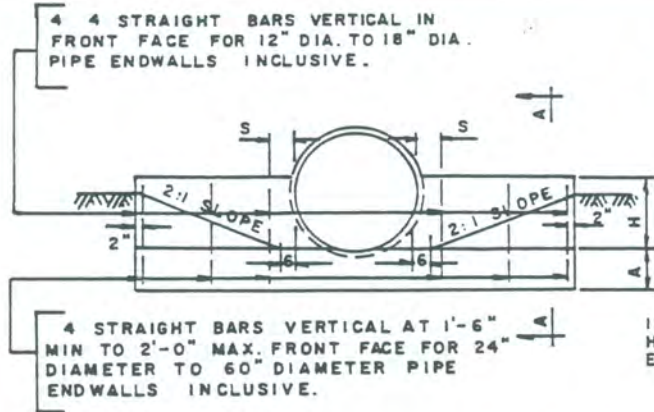

4 4 STRAIGHT BARS VERTICAL IN FRONT FACE FOR 12" DIA. TO 18" DIA. PIPE ENDWALLS INCLUSIVE.

4 STRAIGHT BARS VERTICAL AT 1'-6" MIN TO 2'-0" MAX. FRONT FACE FOR 24" DIAMETER TO 60" DIAMETER PIPE ENDWALLS INCLUSIVE.

"S" DISTANCES FROM INSIDE SURFACE OF PIPE TO VERTICAL BARS IN FRONT AND REAR FACE
 4" FOR 12" DIA. TO 18" DIA. PIPES INCL.
 6" FOR 24" DIA. TO 36" DIA. PIPES INCL.
 8" FOR 42" DIA. TO 60" DIA. PIPES INCL.

ELEVATION

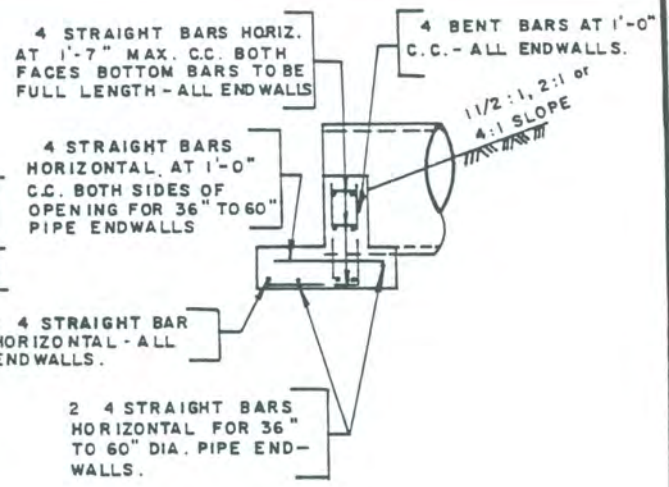

4 STRAIGHT BARS HORIZ. AT 1'-7" MAX. C.C. BOTH FACES BOTTOM BARS TO BE FULL LENGTH - ALL ENDWALLS

4 BENT BARS AT 1'-0" C.C. - ALL ENDWALLS.

4 STRAIGHT BARS HORIZONTAL AT 1'-0" C.C. BOTH SIDES OF OPENING FOR 36" TO 60" PIPE ENDWALLS

1 4 STRAIGHT BAR HORIZONTAL - ALL ENDWALLS.

2 4 STRAIGHT BARS HORIZONTAL FOR 36" TO 60" DIA. PIPE ENDWALLS.

SECTION A-A

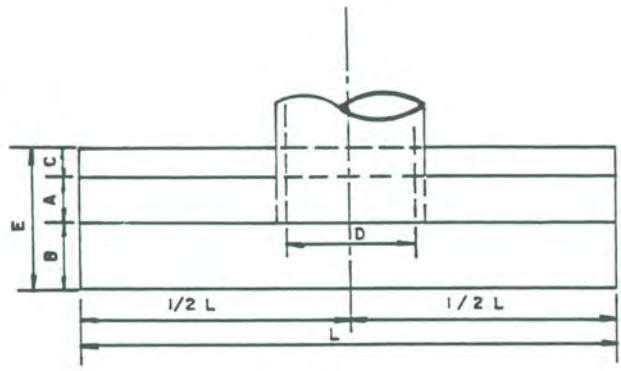

PLAN

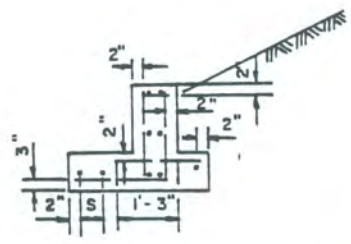

DISPOSITION OF BARS
DETAIL

Openings -		Dimensions						Volume Steel	
D	Area	A	B	C	E	H	L	Conc.	Steel
Inches	Sq. Ft.							C.Y.	Lbs.
12	0.79	9"	6"	6"	1'-9"	0'-10"	4'-0"	0.27	19
15	1.23	9"	6"	6"	1'-9"	1'-0"	4'-9"	0.34	23
18	1.78	9"	6"	6"	1'-9"	1'-3"	5'-6"	0.41	29
24	3.14	9"	14"	6"	2'-5"	1'-6"	7'-0"	0.69	38
30	4.91	9"	14"	6"	2'-5"	1'-9"	8'-6"	0.88	58
36	7.07	12"	16"	10"	3'-2"	2'-0"	10'-0"	1.74	90
42	9.62	12"	16"	10"	3'-2"	2'-3"	11'-6"	2.07	99
48	12.57	12"	16"	10"	3'-2"	2'-6"	13'-0"	2.43	119
54	15.90	12"	20"	12"	3'-8"	2'-9"	14'-6"	3.08	132
60	19.64	12"	20"	12"	3'-8"	3'-0"	16'-0"	3.50	158

Quantities in Table to be used for Estimating Only

General Notes

- Concrete : See Specifications
- Reinforcing : Deformed steel bars + 4 bars (1/2" dia)
- Chamfer : All exposed edges 1x1 or as directed

REVISED	
DATE	BY

CARROLL COUNTY, MARYLAND
DEPARTMENT OF PUBLIC WORKS

[Signature] 4-12-94
DIRECTOR DATE

STANDARD END SUPPORT
WALL ROUND PIPE

PLATE

77

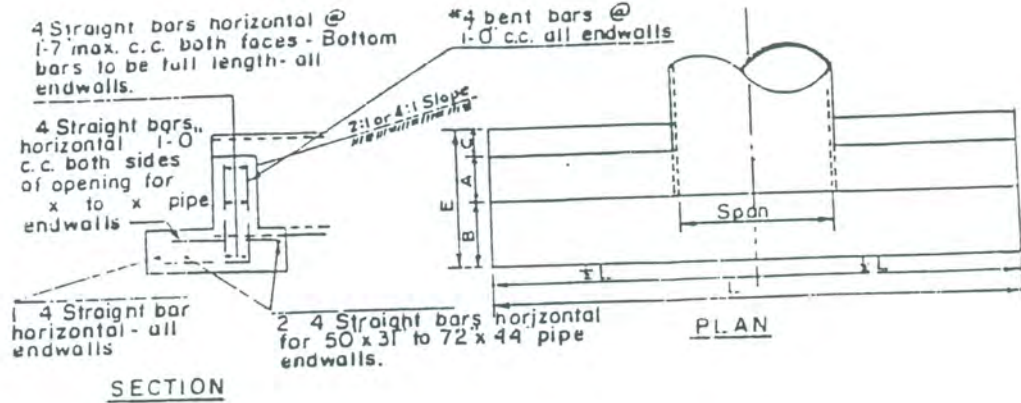

SECTION

PLAN

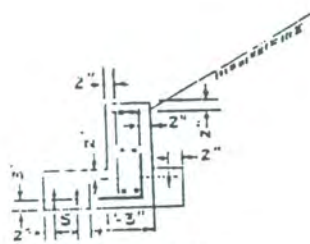

DISPOSITION OF BARS DETAIL

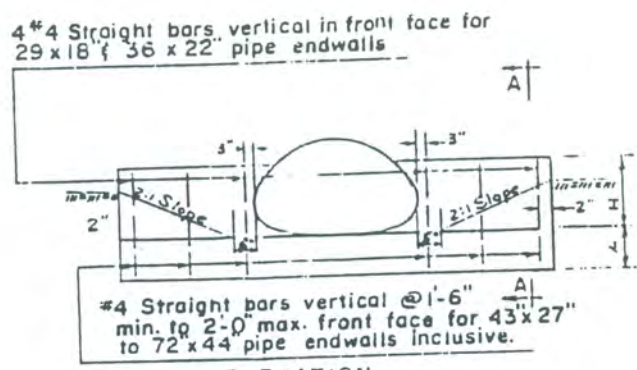

ELEVATION

"S" Distances
 6" for 29"x18" to 43"x27" incl.
 8" for 50"x31" to 72"x44" incl.

GENERAL NOTES

- Concrete Reinforcing Chamfer
- See Specifications
- Deformed Steel bars - 4 bars (#)
- All exposed edges 1"x1" or as directed

QUANTITIES FOR ESTIMATING PURPOSES ONLY

OPENING		DIMENSIONS						QUANTITIES	
SIZE	AREA	A	B	C	E	H	L	CONC. C.Y.	STEEL LBS.
INCHES S X R	SQ. FT.								
28X20	3.14	9"	14"	6"	2'-5"	1'-2"	5'-11"	.50	33
35X24	4.91	9"	14"	6"	2'-5"	1'-5"	7'-5"	.65	37
42X29	7.07	12"	16"	10"	3'-2"	1'-8"	8'-10"	1.32	54
49X33	9.62	12"	16"	10"	3'-2"	1'-11"	10'-4"	1.59	77
57X38	12.57	12"	16"	10"	3'-2"	2'-2"	12'-1"	1.92	90
64X43	15.90	12"	20"	12"	3'-8"	2'-6"	13'-7"	2.51	102
71X47	19.64	12"	20"	12"	3'-8"	2'-9"	15'-1"	2.86	112

REVISION	
DATE	BY

CARROLL COUNTY, MARYLAND
 DEPARTMENT OF PUBLIC WORKS
[Signature] 4-12-94
 DIRECTOR DATE

STANDARD END SUPPORT
 WALL ARCH PIPE

PLATE
 78

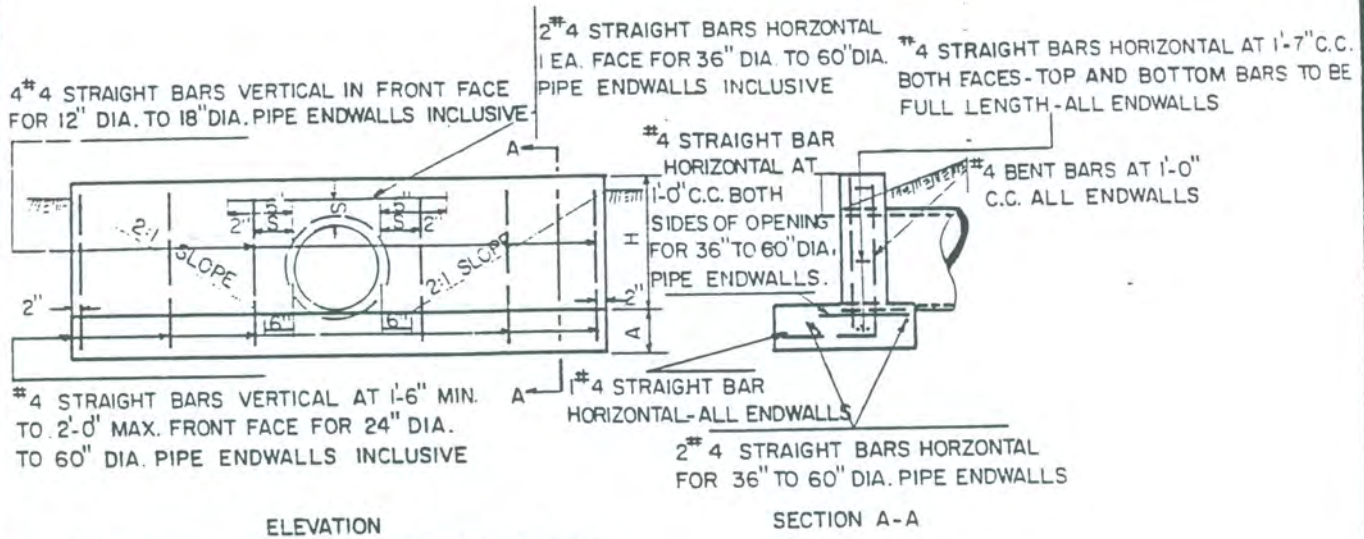

"S" DISTANCES FROM INSIDE SURFACE OF PIPE TO VERTICAL BARS IN FRONT AND FACE.

4" FOR 12" DIA. TO 18" DIA. PIPES INCL.

6" FOR 24" DIA. TO 36" DIA. PIPES INCL.

8" FOR 42" DIA. TO 60" DIA. PIPES INCL.

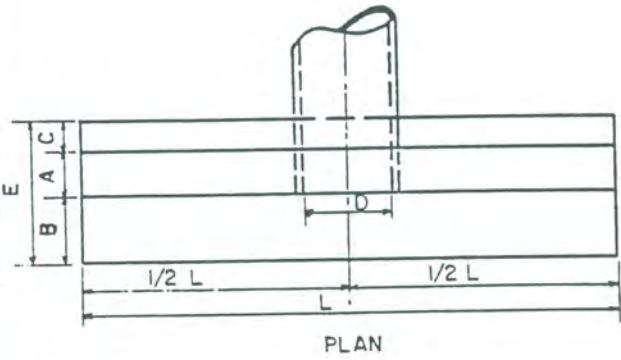

GENERAL NOTES

CONCRETE : SEE SPECIFICATIONS

REINFORCING : DEFORMED STEEL BARS - #4 BARS (1/2" ϕ)

CHAMFER : ALL EXPOSED EDGES 1"X1" OR AS DIRECTED.

OPENINGS D INCHES	AREA SQ. FT.	DIMENSIONS							VOL. CONC. C. Y.	STEEL LBS.
		A	B	C	E	F	H	L		
12	0.79	9"	6"	6"	1'-9"	9"	1'-9"	6'-6"	0.61	38
15	1.23	9"	6"	6"	1'-9"	9"	2'-0"	7'-9"	0.78	55
18	1.78	9"	6"	6"	1'-9"	9"	2'-3"	9'-0"	0.95	62
24	3.14	9"	14"	6"	2'-5"	9"	2'-9"	11'-6"	1.56	91
30	4.91	9"	14"	6"	2'-5"	12"	3'-6"	14'-2"	2.19	136
36	7.07	12"	16"	10"	3'-2"	12"	4'-0"	16'-8"	4.18	222
42	9.62	12"	16"	10"	3'-2"	12"	4'-6"	19'-2"	5.13	265
48	12.57	12"	16"	10"	3'-2"	12"	5'-0"	21'-8"	6.12	326
54	15.90	12"	20"	12"	3'-8"	12"	5'-6"	24'-2"	7.68	384
60	19.64	12"	20"	12"	3'-8"	12"	6'-0"	26'-8"	8.86	428

QUANTITIES IN TABLE TO BE USED FOR ESTIMATING ONLY

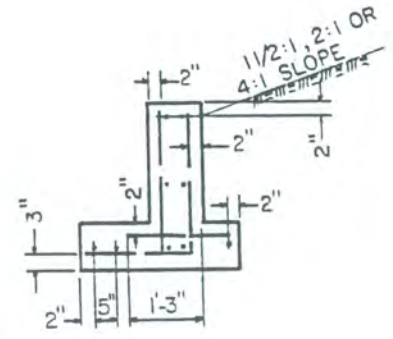

CARROLL COUNTY, MARYLAND
DEPARTMENT OF PUBLIC WORKS

STANDARD TYPE 'C'
ENDWALL ROUND PIPE

REVISED	
DATE	BY
PLATE	
79	

L. S. ... 1-12-91

4 #4 STRAIGHT BARS VERTICAL IN FRONT FACE FOR 14" X 9" TO 29" X 18" PIPE ENDWALLS INCLUSIVE

2 #4 STRAIGHT BARS HORIZONTAL, 1 EACH FACE FOR 50" X 31" TO 72" X 44" PIPE ENDWALLS INCLUSIVE

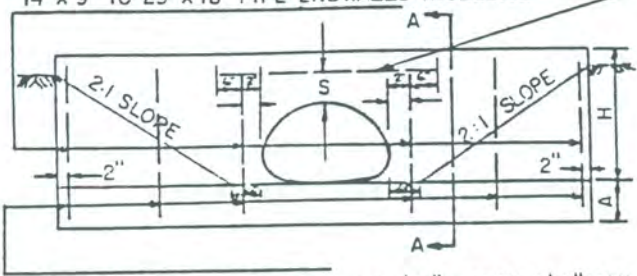

4 #4 STRAIGHT BARS HORIZONTAL AT 1'-7" C.C. BOTH FACES - TOP AND BOTTOM BARS TO BE FULL LENGTH - ALL ENDWALLS

4 #4 STRAIGHT BARS VERTICAL AT 1'-6" MIN. TO 2'-0" MAX. FROM FACE FOR 36" X 22" TO 22" X 44" PIPE ENDWALLS INCLUSIVE

ELEVATION

"S" DISTANCES

- 4" FOR 14" X 9" TO 22" X 13" INCL.
- 6" FOR 29" X 18" TO 43" X 27" INCL.
- 8" FOR 50" X 31" TO 72" X 44" INCL.

4 #4 STRAIGHT BAR HORIZONTAL AT 1'-0" C.C. BOTH SIDES OF OPENING FOR 50" X 31" TO 72" X 44" PIPE ENDWALLS INCLUSIVE

1 #4 STRAIGHT BAR HORIZONTAL ALL BARS

2 #4 STRAIGHT BARS HORIZONTAL FOR 50" X 31" TO 72" X 44" PIPE ENDWALLS, INCL.

SECTION A-A

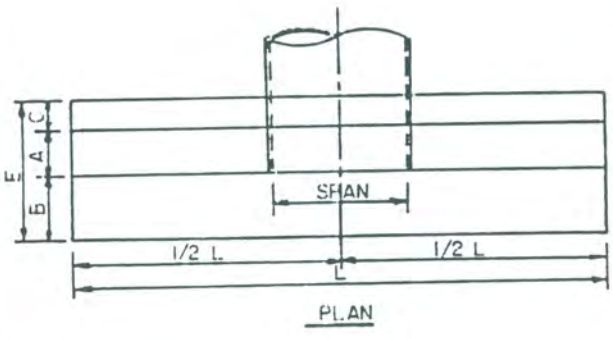
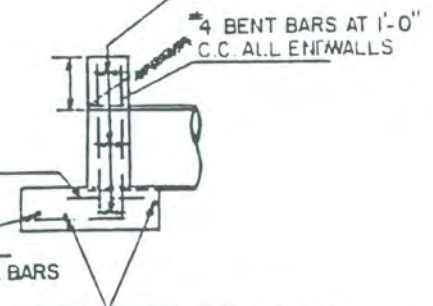

QUANTITIES FOR ESTIMATING PURPOSES ONLY

OPENING		DIMENSIONS							QUANTITIES	
D	AREA	A	B	C	E	F	H	L	CONC.	STEEL
INCHES S X R	SQ. FT.								C.Y.	LBS.
17 X 13	1.23	9"	6"	6"	1'-9"	6"	1'-9"	6'-3"	0.54	38
21 X 15	1.77	9"	6"	6"	1'-9"	11"	2'-2"	9'-6"	0.98	56
24 X 18	2.40	9"	6"	6"	1'-9"	8"	2'-2"	9'-6"	0.96	55
28 X 20	3.14	9"	6"	6"	1'-9"	9"	2'-4"	9'-6"	0.96	55
35 X 24	4.91	9"	14"	6"	2'-5"	14"	3'-2"	13'-8"	1.98	96
42 X 29	7.07	9"	14"	6"	2'-5"	9"	3'-2"	13'-8"	1.92	95
49 X 33	9.62	12"	16"	10"	3'-2"	14"	3'-11"	17'-11"	4.34	186
57 X 38	12.57	12"	16"	10"	3'-2"	10"	4'-0"	17'-11"	4.73	186
64 X 43	15.90	12"	20"	12"	3'-8"	13"	4'-8"	21'-9"	6.27	243
71 X 47	19.64	12"	20"	12"	3'-8"	10"	4'-9"	21'-9"	6.05	243

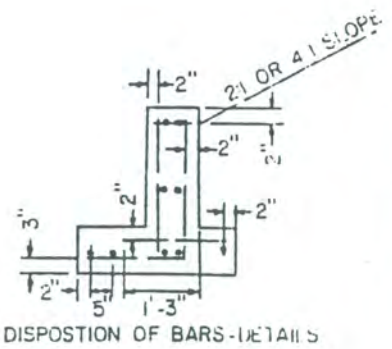

DISPOSITION OF BARS - DETAILS

GENERAL NOTES

- CONCRETE : SEE SPECIFICATIONS
- REINFORCING : DEFORMED STEEL BARS - #4 BARS, (1/2" ϕ)
- CHAMFER : ALL EXPOSED EDGES 1" X 1" OR AS DIRECTED.

CARROLL COUNTY, MARYLAND
DEPARTMENT OF PUBLIC WORKS

W. S. Crawford 4-12-94
DIRECTOR DATE

STANDARD TYPE C
ENDWALL ARCH PIPE

PLATE

80

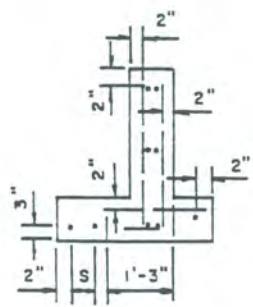
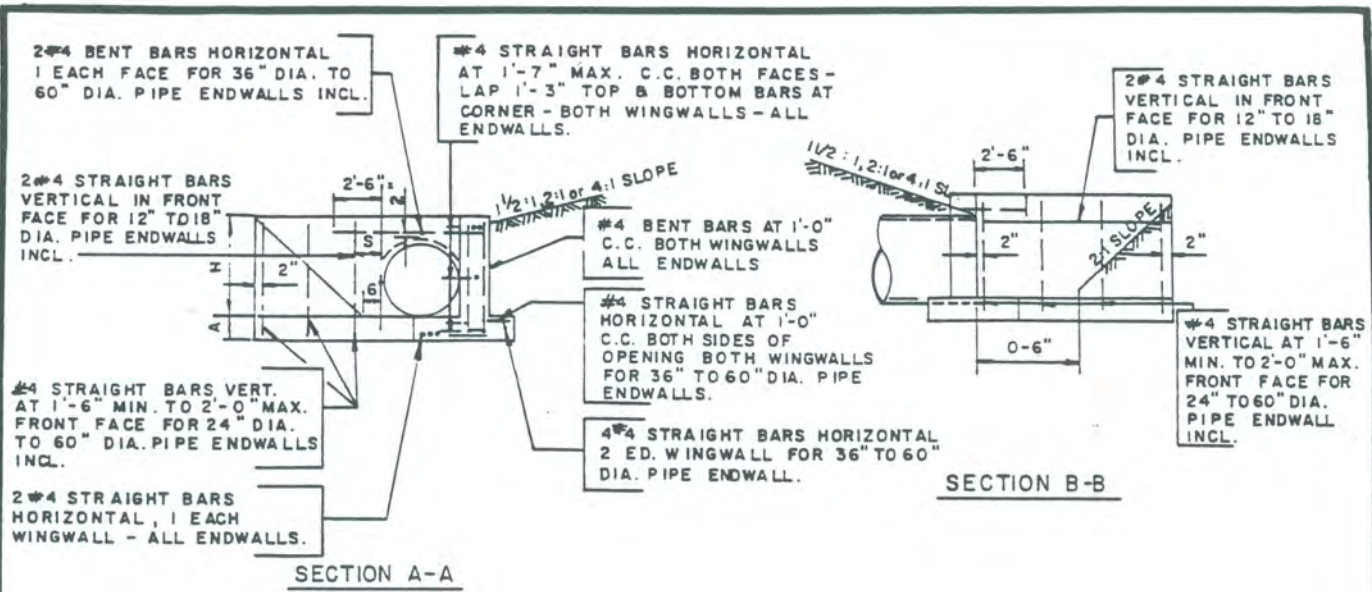

DISPOSITION OF BARS DETAILS

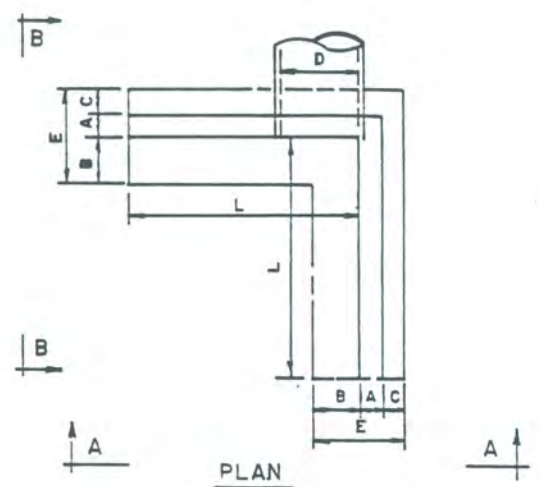

PLAN

Openings		Dimensions						Volume		Steel	
D inches	Area Sq. Ft.	A	B	C	E	H	L	Conc. C.Y.	Lbs.		
12	0.799	9-0	6-0	6	1-9	1-9	3-6	0.73	56		
15	1.23	9-0	6-0	6	1-9	2-0	4-3	0.93	77		
18	1.78	9-0	6-0	6	1-9	3-3	5-0	1.14	89		
24	3.14	9-0	6-0	6	2-5	2-9	6-6	1.8	124		
30	4.91	9-0	6-0	6	2-5	3-6	8-0	2.6	160		
36	7.07	9-0	6-0	10	3-2	4-0	9-6	5.0	287		
42	9.62	12-0	10-0	10	3-2	4-6	11-0	6.2	333		
48	12.57	12-0	10-0	10	3-2	5-0	12-6	7.4	387		
54	15.90	12-0	20-0	12	3-8	5-6	14-0	9.2	458		
60	19.64	12-0	20-0	12	3-8	6-0	15-6	10.7	519		

Quantities in Table to be used for Estimating Only

S Distances from inside surface of pipe to vertical bars in front and rear face
 4" for 12" Dia to 18" Dia pipes incl.
 6" for 24" Dia to 36" Dia pipes incl.
 8" for 42" Dia to 60" Dia pipes incl.

GENERAL NOTES

- Concrete : See specifications.
- Reinforcing : Deformed steel bars - 4 bars ($\frac{1}{2}\phi$)
- Chamfer : All exposed edges 1x1 or as directed.

REVISION	
DATE	BY

CARROLL COUNTY, MARYLAND
 DEPARTMENT OF PUBLIC WORKS
[Signature] 4-12-94
 DIRECTOR DATE

STANDARD TYPE E ENDWALL
 ROUND PIPE

PLATE
 81

2#4 BENT BARS, HORIZONTAL
1 EACH FACE FOR 50" X 31" TO
72" X 44" ENDWALLS, INCL.

#4 STRAIGHT BARS HORIZONTAL AT
1'-7" MAX. C.C. BOTH FACES - LAP 1'-3"
TOP & BOTTOM BARS AT CORNER - BOTH
WINGWALLS - ALL ENDWALLS.

2#4 STRAIGHT BARS
VERTICAL IN
FRONT FACE FOR
14" X 9" TO
29" X 18" ENDWALLS
INCL.

2:1 or 4:1 SLOPE

#4 BENT BARS AT 1'-0"
C.C. BOTH WINGWALLS ALL
ENDWALLS

#4 STRAIGHT BARS HORIZONTAL AT
1'-0" C.C. BOTH SIDES OF OPENING FOR
BOTH WINGWALLS FOR 50" X 31" TO
72" X 44" ENDWALLS INCL.

#4 STRAIGHT BARS VERTICAL
AT 1'-6" MIN. TO 2'-0" MAX.
FRONT FACE FOR 36" X 22"
TO 72" X 44" ENDWALLS, INCL.

4#4 STRAIGHT BARS HORIZONTAL,
2 EACH WINGWALL FOR 50" X 31"
TO 72" X 44" ENDWALLS INCL.

2#4 STRAIGHT BARS
HORIZONTAL, 1 EACH
WINGWALL - ALL ENDWALL

SECTION A-A

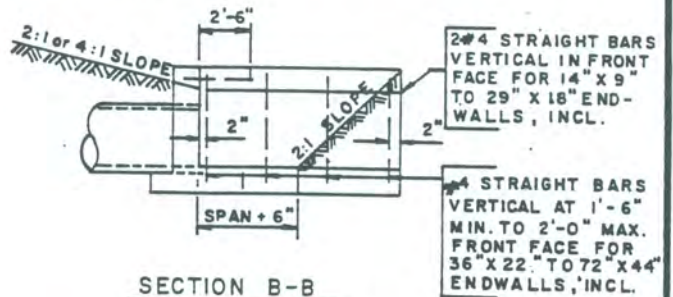

SECTION B-B

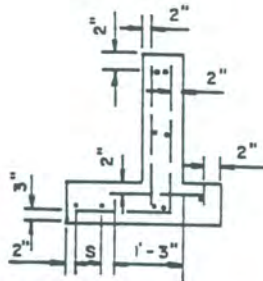

DISPOSITION OF BARS DETAIL

GENERAL NOTES

Concrete : See Specifications
Reinforcing : Deformed steel bars 4 bars (1/2" o)
Chamfer : All exposed edges 1" X 1"

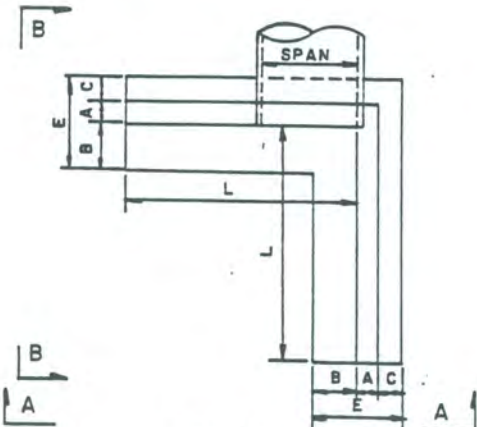

PLAN

QUANTITIES FOR ESTIMATING PURPOSES

OPENING		DIMENSIONS							QUANTITIES	
D	AREA	A	B	C	E	F	H	L	CONC.	STEEL
INCHES	S.F.								CY.	LBS.
S X R										
17x13	1.23	9"	6"	6"	1'-9"	6"	1'-9"	6'-3"	0.54	38
21x15	1.77	9"	6"	6"	1'-9"	11"	2'-2"	9'-6"	0.98	56
24x18	2.40	9"	6"	6"	1'-9"	8"	2'-2"	9'-6"	0.96	55
28x20	3.14	9"	6"	6"	1'-9"	9"	2'-4"	9'-6"	0.96	55
35x24	4.91	9"	14"	6"	2'-5"	14"	3'-2"	8'-8"	1.98	96
42x29	7.07	9"	14"	6"	2'-5"	9"	3'-2"	13'-8"	1.92	95
49x33	9.62	12"	16"	10"	3'-2"	14"	3'-11"	17'-11"	4.34	186
57x38	12.57	12"	16"	10"	3'-2"	10"	4'-0"	17'-11"	4.73	186
64x43	15.90	12"	20"	12"	3'-8"	13"	4'-8"	21'-9"	6.27	243
71x47	19.64	12"	20"	12"	3'-8"	10"	4'-9"	21'-9"	6.05	243

"S" DISTANCES

4" for 14" x 9" to 22" x 13" incl.
6" for 29" x 18" to 43" x 27" incl.
8" for 50" x 31" to 72" x 44" incl.

REVISED	
DATE	BY

CARROLL COUNTY, MARYLAND
DEPARTMENT OF PUBLIC WORKS

C. S. Stankard 4-12-11
DIRECTOR DATE

STANDARD TYPE E
ENDWALL ARCH PIPE

PLATE

82

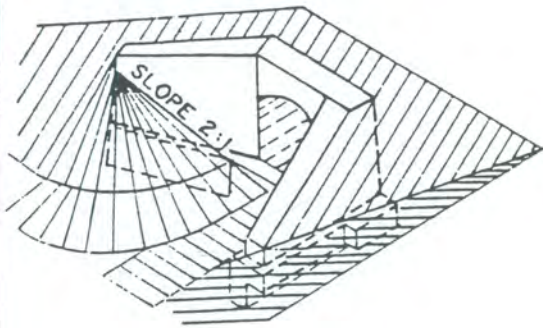

ISOMETRIC VIEW

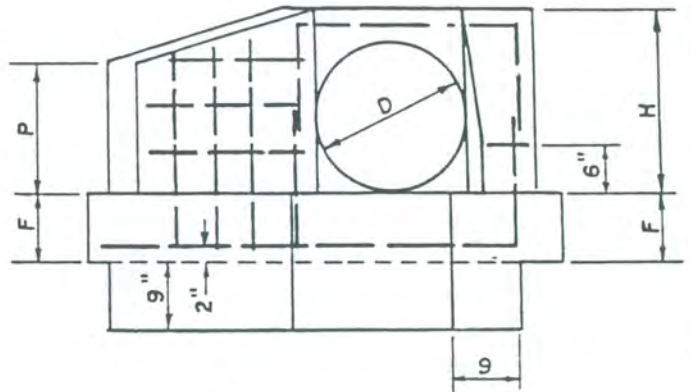

ELEVATION

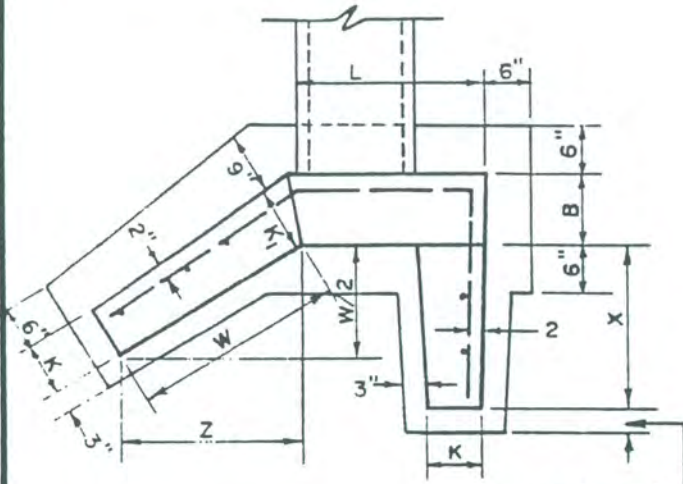

PLAN

1 1/2 : 1 SLOPE = 9"
2 : 1 SLOPE = 12"
4 : 1 SLOPE = 24"

CONCRETE, MIX No. 2 (AIR-ENTRAINED)
REINFORCEMENT, DEFORMED STEEL BARS.
CHAMFER ALL EXPOSED EDGES 1" x 1"
OR AS DIRECTED.

STEEL IN WINGS

VERT. 3/4" ϕ BARS 12" C.C.
HOR. 1/2" ϕ BARS 12" C.C.
HOOKED ON ONE END

SLOPE 1 1/2 : 1

PIPE DIA.	AREA SQ FT	DIMENSIONS FOR CONCRETE									
		ENDWALLS					WINGS				
		L	B	F	H	W	X	Z	K	K	P
12"	0.79	1'-9"	9"	9"	1'-8"	2'-0"	1'-3"	1'-9"	9"	7"	1'-4"
15"	1.23	2'-0"	9"	9"	2'-0"	2'-4"	1'-9"	2'-0"	9"	7"	1'-5"
16"	1.39	2'-1"	9"	9"	2'-0"	2'-4"	1'-9"	2'-0"	9"	7"	1'-5"
18"	1.78	2'-3"	9"	9"	2'-3"	2'-8"	2'-1"	2'-4"	9"	8"	1'-6"
24"	3.14	3'-0"	12"	9"	2'-11"	3'-6"	2'-11"	3'-0"	12"	11"	2'-1"
30"	4.91	3'-6"	12"	9"	3'-6"	4'-4"	3'-9"	3'-9"	12"	11"	2'-4"
36"	7.07	4'-0"	12"	9"	4'-0"	5'-0"	4'-6"	4'-4"	12"	11"	2'-7"
42"	9.62	4'-6"	12"	9"	4'-7"	5'-9"	5'-4"	5'-0"	12"	11"	2'-1"
48"	12.57	5'-0"	12"	9"	5'-1"	6'-4"	6'-2"	5'-6"	12"	11"	3'-3"

SLOPE 2 : 1

PIPE DIA.	AREA SQ FT	DIMENSIONS FOR CONCRETE									
		ENDWALLS					WINGS				
		L	B	F	H	W	X	Z	K	K	P
12"	0.79	1'-9"	9"	9"	1'-7"	2'-3"	1'-10"	2'-0"	9"	7"	1'-3"
15"	1.23	2'-0"	9"	9"	1'-11"	2'-6"	2'-6"	2'-2"	9"	8"	1'-5"
16"	1.39	2'-1"	9"	9"	1'-11"	2'-7"	2'-6"	2'-3"	9"	8"	1'-5"
18"	1.78	2'-3"	9"	9"	2'-2"	3'-0"	3'-0"	2'-7"	9"	8"	1'-7"
24"	3.14	3'-0"	12"	9"	2'-9"	4'-0"	4'-0"	3'-5"	12"	11"	2'-1"
30"	4.91	3'-6"	12"	9"	3'-4"	4'-8"	5'-2"	4'-1"	12"	11"	2'-6"
36"	7.07	4'-0"	12"	9"	3'-10"	5'-4"	6'-2"	4'-7"	12"	11"	2'-10"
42"	9.62	4'-6"	12"	9"	4'-5"	6'-4"	7'-4"	5'-6"	12"	11"	3'-2"
48"	12.57	5'-0"	12"	9"	4'-11"	7'-0"	8'-4"	6'-1"	12"	11"	3'-6"

SLOPE 4 : 1

PIPE DIA.	AREA SQ FT	DIMENSIONS FOR CONCRETE									
		ENDWALLS					WINGS				
		L	B	F	H	W	X	Z	K	K	P
12"	0.79	1'-9"	9"	9"	1'-5"	2'-6"	3'-8"	2'-2"	9"	8"	1'-3"
15"	1.23	2'-0"	9"	9"	1'-9"	3'-0"	5'-0"	2'-7"	9"	8"	1'-5"
16"	1.39	2'-1"	9"	9"	1'-9"	3'-0"	5'-0"	2'-7"	9"	8"	1'-5"
18"	1.78	2'-3"	9"	9"	2'-0"	3'-6"	6'-0"	3'-0"	9"	8"	1'-7"
24"	3.14	3'-0"	12"	9"	2'-6"	4'-6"	8'-0"	3'-11"	12"	11"	2'-2"
30"	4.91	3'-6"	12"	9"	3'-1"	5'-6"	10'-4"	4'-9"	12"	11"	2'-7"
36"	7.07	4'-0"	12"	9"	3'-7"	6'-6"	12'-4"	5'-8"	12"	11"	3'-0"
42"	9.62	4'-6"	12"	9"	4'-2"	7'-6"	14'-8"	6'-6"	12"	11"	3'-5"
48"	12.57	5'-0"	12"	9"	4'-8"	8'-3"	16'-8"	7'-2"	12"	11"	3'-10"

CARROLL COUNTY, MARYLAND
DEPARTMENT OF PUBLIC WORKS

[Signature] 4-12-41
DIRECTOR DATE

"F" ENDWALL

PLATE

83

CARROLL COUNTY, MARYLAND
DEPARTMENT OF PUBLIC WORKS

W. St. ...
DIRECTOR DATE 4-12-94

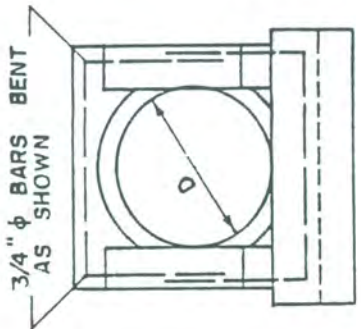
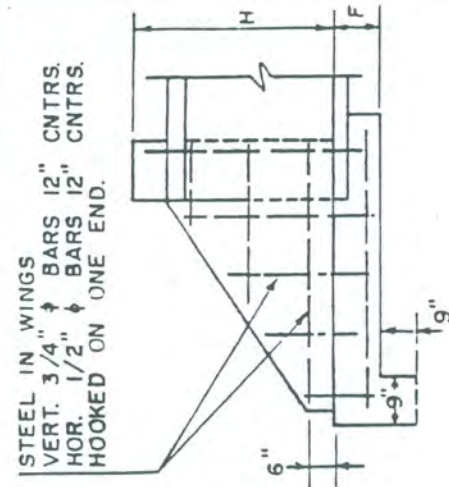

STEEL IN WINGS
VERT. 3/4" φ BARS 12" CNTRS.
HOR. 1/2" φ BARS 12" CNTRS.
HOOKED ON ONE END.

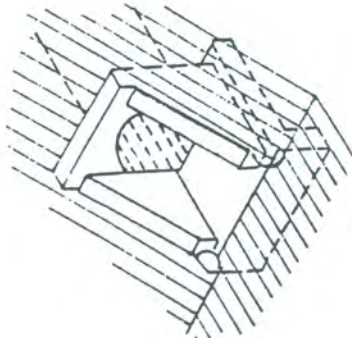

1 1/2" | SLOPE = 9"
2 | SLOPE = 12"
4 | SLOPE = 24"

PLAN

ISOMETRIC VIEW

ELEVATION

SECTION A-A

CONCRETE, MIX No. 2 (AIR-ENTRAINED)
REINFORCEMENT, DEFORMED STEEL BARS
CHAMFER ALL EXPOSED EDGES 1" x 1" AS DIRECTED.

SLOPE 1 1/2 : 1		SLOPE 2 : 1																														
DIMENSIONS FOR CONCRETE		DIMENSIONS FOR CONCRETE																														
OPENING	D SQFT	ENDWALLS						WINGS						OPENING	DIMENSIONS FOR CONCRETE																	
		L	B	F	H	W	K	L	B	F	H	W	K		L	B	F	H	W	K												
12"	0.79	2'-0"	9"	9"	1'-8"	1'-0"	6"	6"	9"	9"	1'-7"	1'-4"	6"	6"	12"	0.79	2'-0"	9"	9"	1'-7"	1'-4"	6"	6"	12"	0.79	2'-0"	9"	9"	1'-7"	1'-4"	6"	6"
15"	1.23	2'-3"	9"	9"	2'-0"	1'-5"	6"	6"	9"	9"	1'-11"	1'-11"	6"	6"	15"	1.23	2'-3"	9"	9"	1'-11"	1'-11"	6"	6"	15"	1.23	2'-3"	9"	9"	1'-11"	1'-11"	6"	6"
16"	1.39	2'-4"	9"	9"	2'-0"	1'-6"	6"	6"	9"	9"	1'-11"	2'-0"	6"	6"	16"	1.39	2'-4"	9"	9"	1'-11"	2'-0"	6"	6"	16"	1.39	2'-4"	9"	9"	1'-11"	2'-0"	6"	6"
18"	1.78	2'-6"	9"	9"	2'-3"	1'-10"	6"	6"	9"	9"	2'-2"	2'-6"	6"	6"	18"	1.78	2'-6"	9"	9"	2'-2"	2'-6"	6"	6"	18"	1.78	2'-6"	9"	9"	2'-2"	2'-6"	6"	6"
24"	3.14	3'-6"	12"	9"	2'-11"	2'-8"	9"	9"	9"	9"	2'-9"	3'-6"	9"	9"	24"	3.14	3'-6"	12"	9"	2'-9"	3'-6"	9"	9"	24"	3.14	3'-6"	12"	9"	2'-9"	3'-6"	9"	9"
30"	4.91	4'-0"	12"	9"	3'-6"	3'-6"	9"	9"	9"	9"	3'-4"	4'-7"	9"	9"	30"	4.91	4'-0"	12"	9"	3'-4"	4'-7"	9"	9"	30"	4.91	4'-0"	12"	9"	3'-4"	4'-7"	9"	9"
36"	7.07	4'-6"	12"	9"	4'-0"	4'-3"	9"	9"	9"	9"	3'-10"	5'-8"	9"	9"	36"	7.07	4'-6"	12"	9"	3'-10"	5'-8"	9"	9"	36"	7.07	4'-6"	12"	9"	3'-10"	5'-8"	9"	9"
42"	9.62	5'-6"	12"	9"	4'-7"	5'-1"	9"	12"	9"	9"	4'-5"	6'-9"	12"	12"	42"	9.62	5'-6"	12"	9"	4'-5"	6'-9"	12"	12"	42"	9.62	5'-6"	12"	9"	4'-5"	6'-9"	12"	12"
48"	12.57	6'-0"	12"	9"	5'-1"	5'-1"	9"	12"	9"	9"	4'-11"	7'-10"	12"	12"	48"	12.57	6'-0"	12"	9"	4'-11"	7'-10"	12"	12"	48"	12.57	6'-0"	12"	9"	4'-11"	7'-10"	12"	12"

"G" ENDWALL

PLATE

84

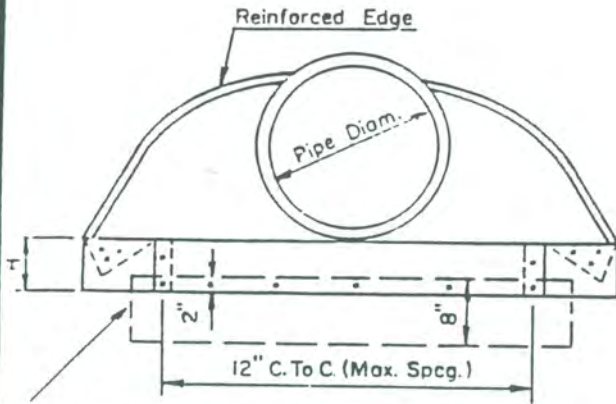

Optional Galvanized Toe Plate (See Note 3) **END VIEW**

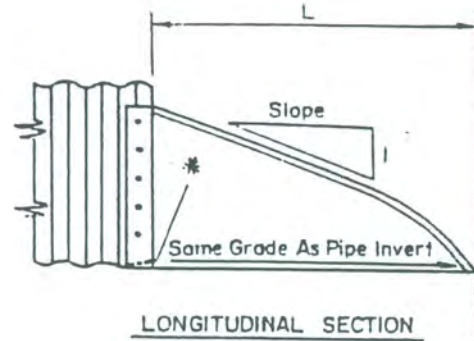

* Invert Elevation To Be At The Pipe End Of The Standard End Section. Elevations To Be Noted On Construction Plans.

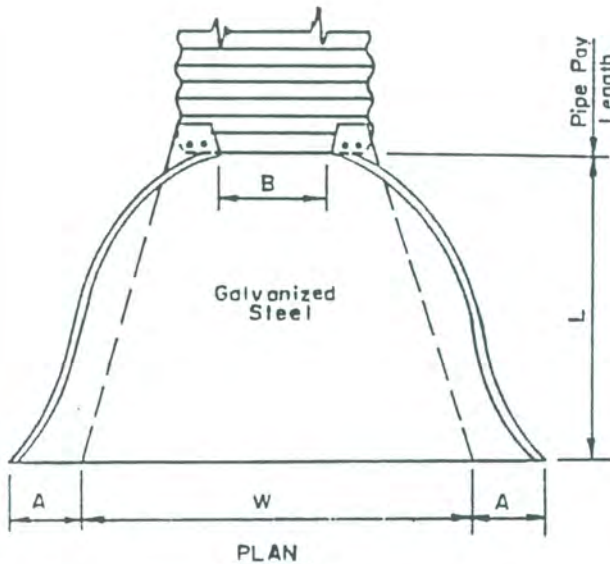

TABLE OF DIMENSIONS									
Pipe Diam	Ga.	A 1"±	B Max.	H 1"±	L 1/2"±	W 2"±	Approx Slope	Body	
12"	16	6"	6"	6"	21"	24"	2 1/2	1 Pc.	
15"	16	7"	8"	6"	26"	30"	2 1/2	1 Pc.	
18"	16	8"	10"	6"	31"	36"	2 1/2	1 Pc.	
21"	16	9"	12"	6"	36"	42"	2 1/2	1 Pc.	
24"	16	10"	13"	6"	41"	48"	2 1/2	1 Pc.	
30"	14	12"	16"	8"	51"	60"	2 1/2	1 Pc.	
36"	14	14"	19"	9"	60"	72"	2 1/2	2 Pc.	
42"	12	16"	22"	11"	69"	84"	2 1/2	2 Pc.	
48"	12	18"	27"	12"	78"	90"	2 1/4	2 Pc.	
54"	12	18"	30"	12"	84"	102"	2	2 Pc.	
60"	12	18"	33"	12"	87"	114"	1 3/4	3 Pc.	
66"	12	18"	36"	12"	87"	120"	1 1/2	3 Pc.	
72"	12	18"	39"	12"	87"	126"	1 1/3	3 Pc.	
78"	12	18"	42"	12"	87"	132"	1 1/4	3 Pc.	
84"	12	18"	45"	12"	87"	138"	1 1/6	3 Pc.	

Notes:

- All 3 Piece Bodies To Have 12 Ga. Sides And 10 Ga. Center Panels. Width Of Center Panels To Be Greater Than 20% Of The Pipe Periphery. Multiple Panel Bodies To Have Lap Seams Which Are To Be Tightly Joined By 3/8" Φ Galvanized Rivets Or Bolts.
- For 60" Thru 84" Sizes, Reinforced Edges To Be Supplemented With Galvanized Stiffener Angles. The Angles Will Be 2" X 2" X 1/4" For 60" Thru 72" Diameter And 2 1/2" X 2 1/2" X 1/4" For 78" And 84" Diameter. The Angles To Be Attached By 3/8" Φ Galvanized Nuts And Bolts.
- Toe Plate Shall Be Used When Specified On The Plans. Cost Of Toe Plate To Be Included In Bid Price Per Each Of Metal End Section.
- Type 3 Connection Includes One Foot Of Pipe Length For 42" Thru 84" Diameter As A Connector Section. The Connector Section Will Be Attached To The End Section By Galvanized Rivets Or Bolts. See Plate No. 87

- Where End Section is To Be Applied To A Structural Plate Pipe, The End Section Shall Be Orderd Without The One Foot Of Pipe Length As Stipulated In Note 4, Instead, Drill Holes And Field Bolt The End Section Directly To The Structural Plate Pipe.

REVISED	
DATE	BY

PLATE

85

CARROLL COUNTY, MARYLAND
DEPARTMENT OF PUBLIC WORKS

[Signature] 4-12-94
DIRECTOR DATE

STANDARD METAL END SECTION
ROUND METAL PIPE

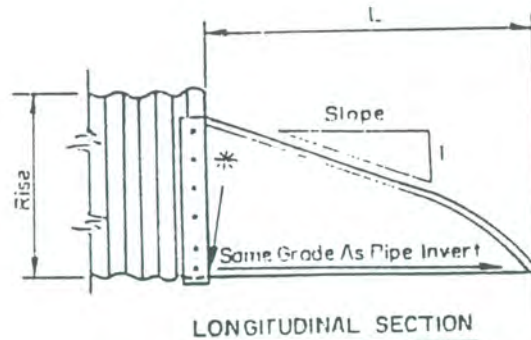
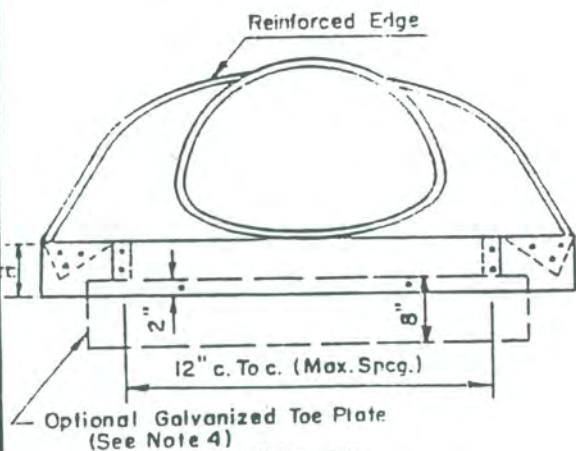

* Invert Elevation To Be At The Pipe End Of The Standard End Section. Elevations To Be Noted On Construction Plans

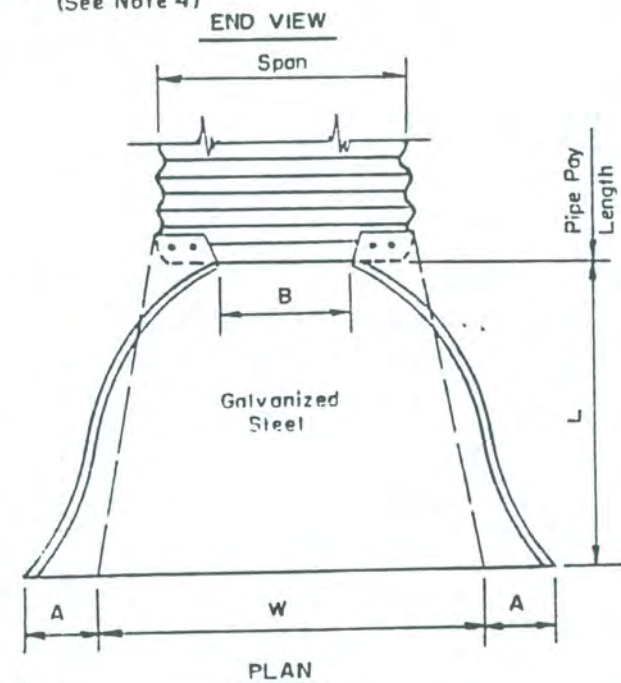

PIPE ARCH DIMENSIONS		DIMENSIONS								
SPAN	RISE	GA.	A 1" ±	B MAX.	H 1" ±	L 1 1/2" ±	W 2" ±	APPROX. SLOPE	UNIT	
17"	13"	16	7"	9"	6"	19"	30"	2 1/4	1 PC.	
21"	15"	16	7"	10"	6"	23"	36"	2 1/2	1 PC.	
24"	18"	16	8"	12"	6"	28"	42"	2 1/2	1 PC.	
28"	20"	16	9"	14"	6"	32"	48"	2 1/2	1 PC.	
35"	24"	14	10"	16"	6"	39"	60"	2 1/2	1 PC.	
42"	29"	14	12"	18"	8"	46"	75"	2 1/2	1 PC.	
49"	33"	12	13"	21"	9"	53"	85"	2 1/2	2 PC.	
57"	38"	12	18"	26"	12"	63"	90"	2 1/2	2 OR 3 PC.	
64"	43"	12	18"	30"	12"	70"	102"	2 1/4	2 OR 3 PC.	
71"	47"	12	18"	33"	12"	77"	114"	2 1/4	3 PC.	
77"	52"	12	18"	36"	12"	77"	126"	2	3 PC.	
83"	57"	12	18"	39"	12"	77"	138"	2	3 PC.	

5. Type 3 Connection Includes One Foot Of Pipe Length For 65" X 40" Thru 85" X 54" Diameter As A Connector Section. The Connector Section Will Be Attached To The End Section By Galvanized Rivets Or Bolts.

Notes:

- All 3 Piece Bodies To Have 12 Ga. Sides And 10 Ga. Center Panels. Width Of Center Panels To Be Greater Than 20% Of The Pipe Periphery. Multiple Panel Bodies To Have Lap Seams Which Are To Be Tightly Joined By 3/8" Galvanized Rivets Or Bolts.
- For The 79" X 49" And 85" X 54" Sizes, Reinforced Edge To Be Supplemented By 2" X 2" X 1/4" Galvanized Angles. The Angles To Be Attached By 3/8" Galvanized Nuts And Bolts.
- Angle Reinforcement Will Be Placed Under The Center Panel Seams On The 79" X 49" And 85" X 54" Sizes.
- Toe Plate Shall Be Used When Specified On The Plans. Cost Of Toe Plate To Be Included In Bid Price Per Each Of Metal End Section.

6. Where End Section is To Be Applied To A Structural Plate Arch Pipe, The End Section Shall Be Ordered Without The One Foot Of Pipe Length As Stipulated In Note 5, Instead Drill Holes And Field Bolt The End Section Directly To The Structural Plate Arch Pipe.

REVISED	
DATE	BY

CARROLL COUNTY, MARYLAND
DEPARTMENT OF PUBLIC WORKS

[Signature] 4-12-94
DIRECTOR DATE

STANDARD METAL END
SECTION ARCH METAL PIPE

PLATE

86

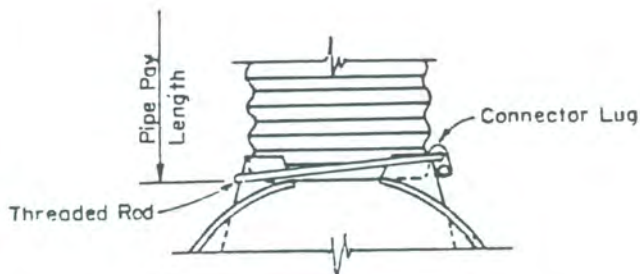

TYPE 1
For 12" Thru 24" Only

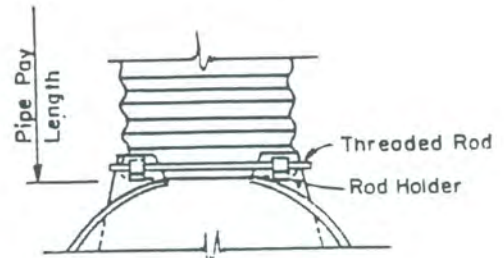

TYPE 2
For 30" And 36" Only

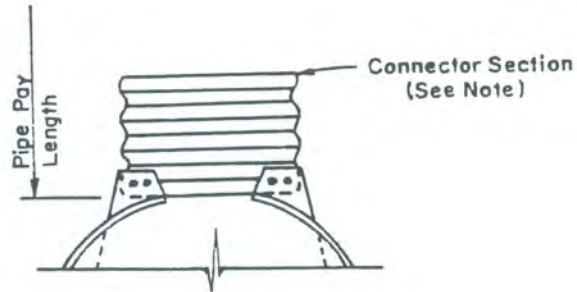

TYPE 3
For 42" Thru 84" Only

CONNECTIONS FOR ROUND PIPE

Notes:

- A. Type 3 Connection Includes One Foot Of The Pipe Length For 65" X 40" Thru 85" X 54" Sizes As A Connector Section. The Connector Section Will Be Attached To The End Section By Galvanized Rivets Or Bolts.
- B. Where End Section Is To Be Applied To A Structural Plate Pipe Or Structural Plate Arch Pipe The End Section Shall Be Ordered Without The One Foot Of Pipe Length. Instead, Drill Holes And Field Bolt The End Section Directly To The Structural Plate Pipe Or Structural Plate Arch Pipe.

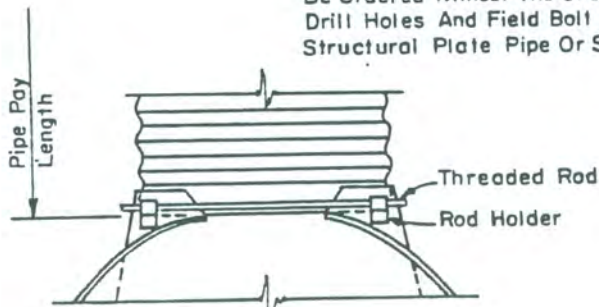

TYPE 2
For 18" X 11" Thru 58" X 36" Only

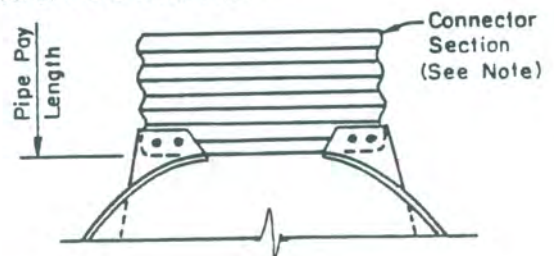

TYPE 3
For 65" X 40 Thru 85" X 54" Only

CONNECTIONS FOR ARCH PIPE

REVISED	
DATE	BY
PLATE	

CARROLL COUNTY, MARYLAND
DEPARTMENT OF PUBLIC WORKS

[Signature] 4-12-94
DIRECTOR DATE

STANDARD CONNECTIONS
METAL END SECTIONS

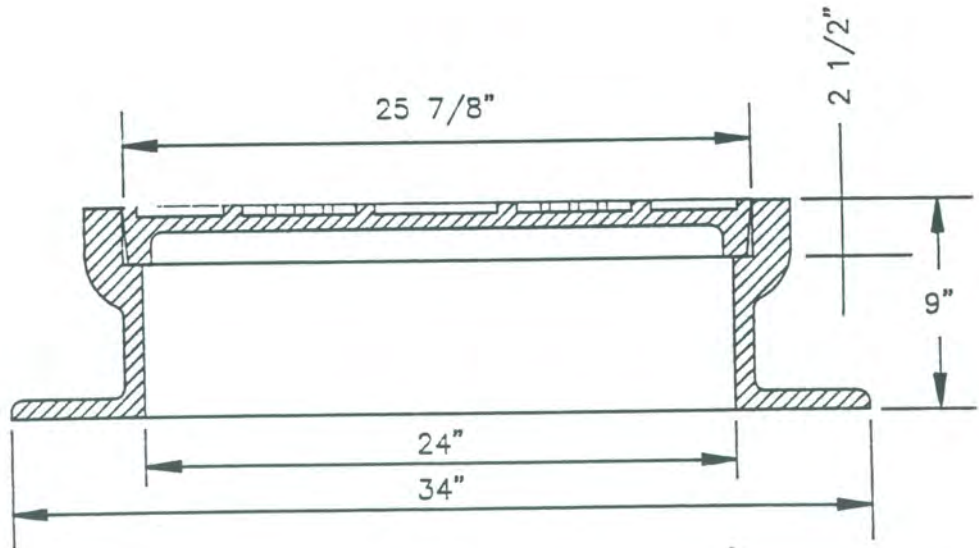
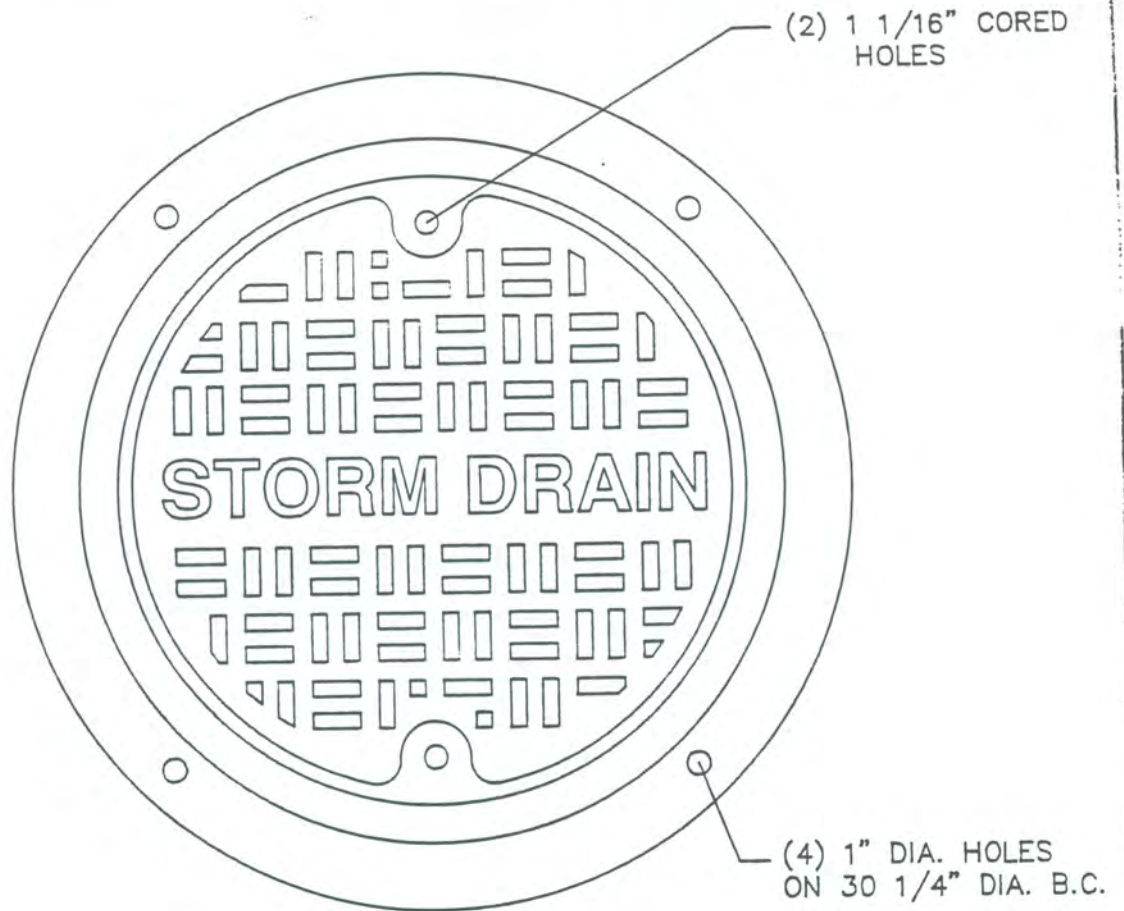

REVISED	
DATE	BY

CARROLL COUNTY, MARYLAND
DEPARTMENT OF PUBLIC WORKS

W. S. ... 4-12-94
DIRECTOR DATE

STANDARD MANHOLE COVER

PLATE

88

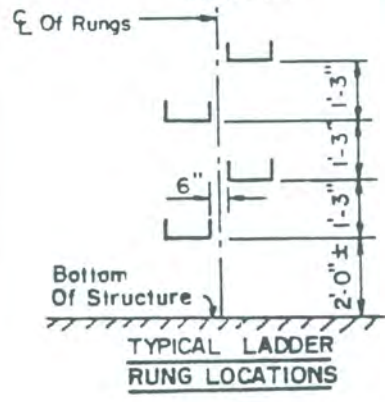
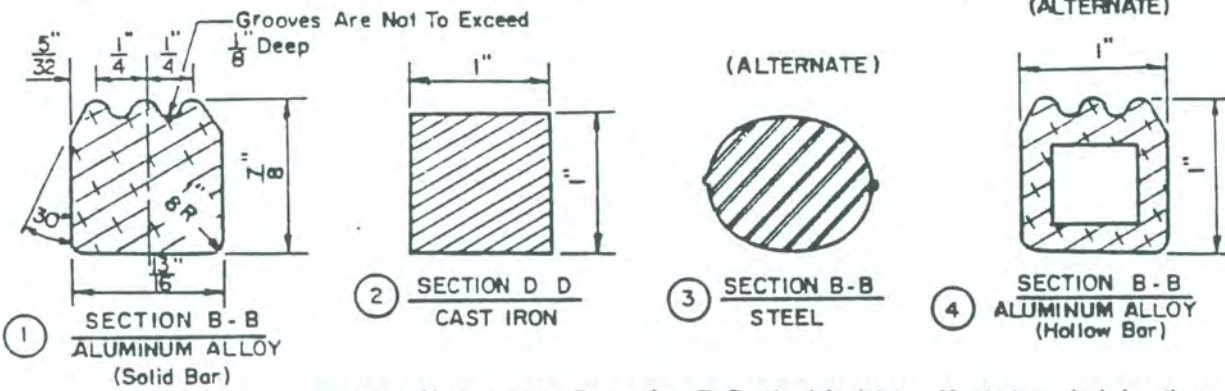
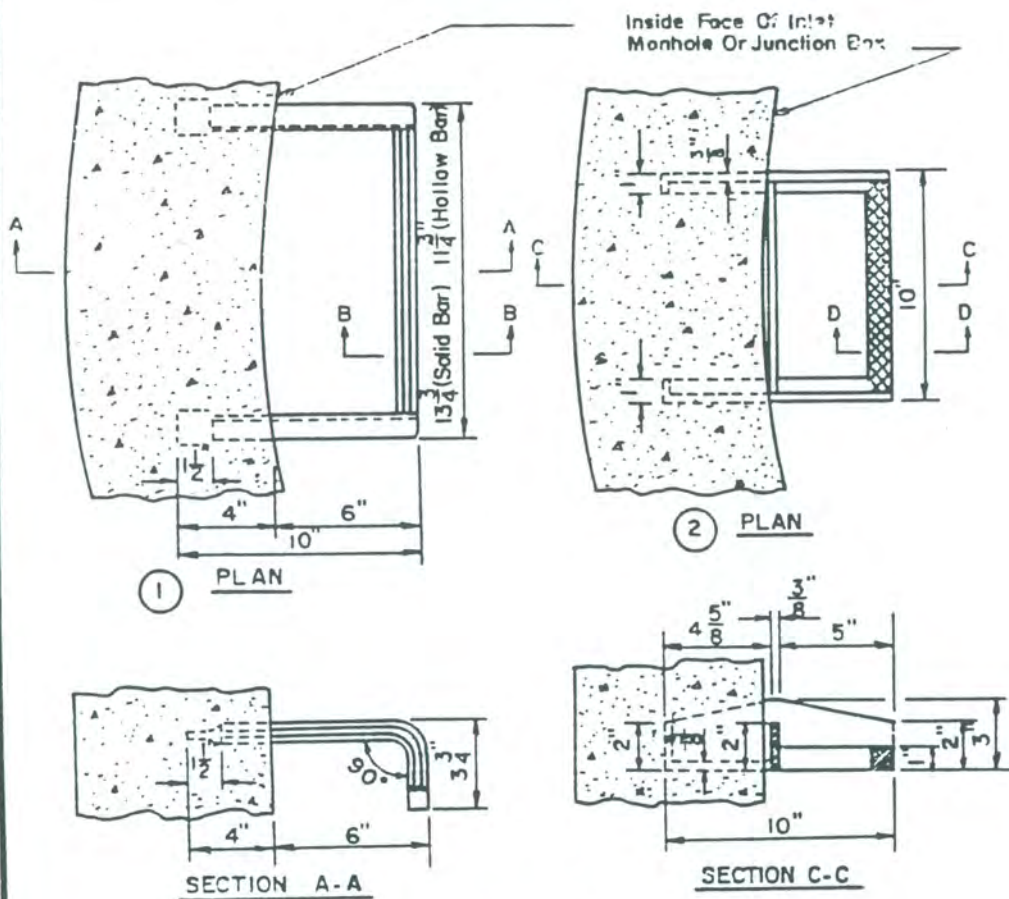

Note: Metal Ladder Rungs Are To Be Used In Inlets, Manholes, And Junction Boxes Over Three Feet In Depth Or As Directed By The Engineer, Used Either With Brick Or Concrete Construction. Where Brick Construction Is Employed, The Mortar Joints Shall Be Adjusted To Accomodate Ladder Rungs Metal Ladder Rungs May Be Comprised Of One Of The Following.

- ① Aluminum Alloy - Shall Conform To A.S.T.M. Designation B 221 Alloy 6061-T6. That Portion Embedded In The Structure Shall Be Coated With Zinc Chromate Or Approved Equivalent Coating.
- ② Cast Iron - Shall Conform To A.S.T.M. Designation 48 Class 30B.
- ③ Steel - Shall Conform To A.S.T.M. Designation A- 615 Grade 40, Galvanized After Fabrication As Per A.S.T.M Designation A-153
- ④ Aluminum Alloy - Shall Conform To A.S.T.M. Designation B221 Alloy 6061-T6. That Portion Embedded In The Structure Shall Be Coated With Zinc Chromate Or Approved Equivalent Coating.

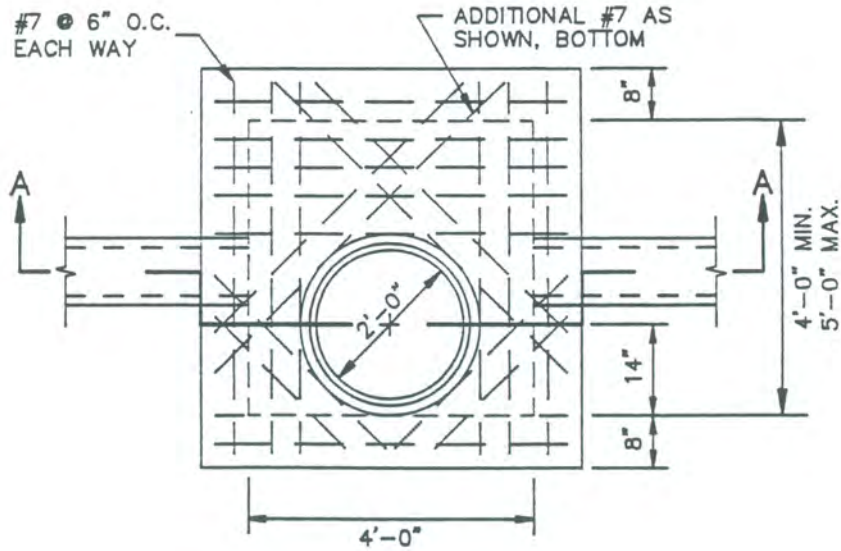

PLAN

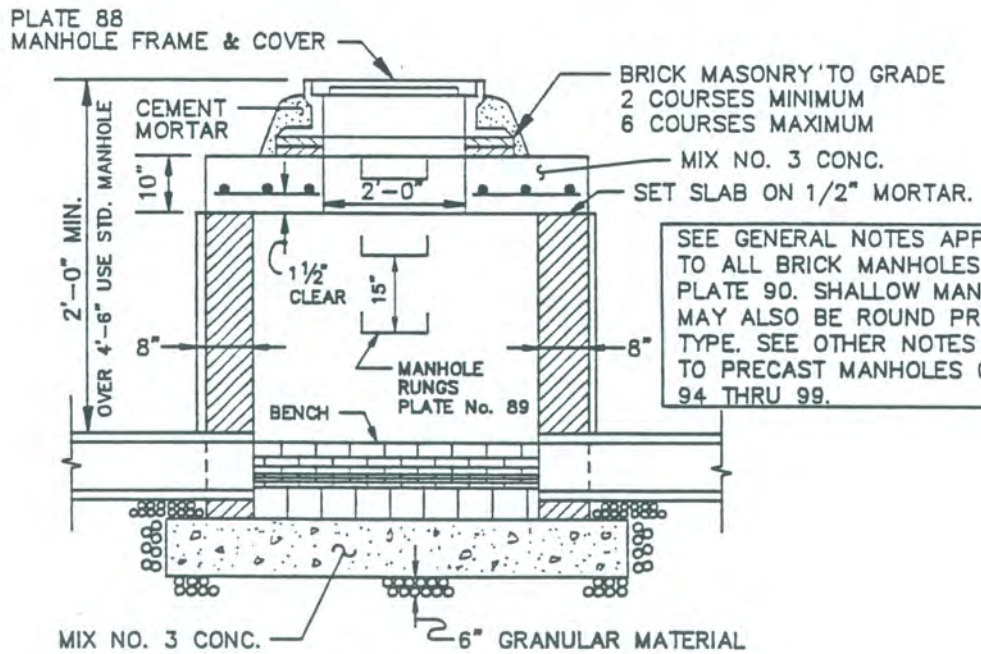

SEE GENERAL NOTES APPLICABLE TO ALL BRICK MANHOLES ON PLATE 90. SHALLOW MANHOLES MAY ALSO BE ROUND PRECAST TYPE. SEE OTHER NOTES APPLICABLE TO PRECAST MANHOLES ON PLATES 94 THRU 99.

SECTION A-A

REVISED	
DATE	BY

CARROLL COUNTY, MARYLAND
DEPARTMENT OF PUBLIC WORKS

K. St. Clair 4-12-94
DIRECTOR DATE

SHALLOW MANHOLE

PLATE

89-A

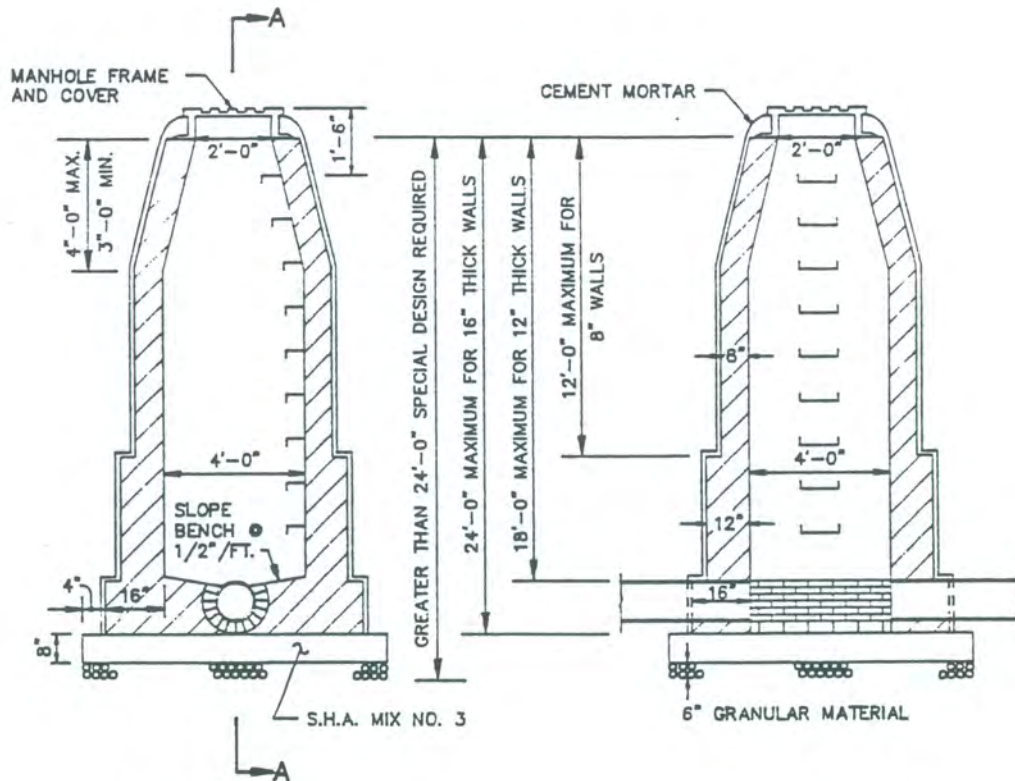

ELEVATION

NO SCALE

SECTION A-A

NO SCALE

GENERAL NOTES APPLICABLE TO ALL BRICK MANHOLES

1. MANHOLE BASE SHALL BE 8-INCH CAST IN PLACE CONCRETE SLAB, MIX NO. 3 AIR ENTRAINED. ALL OTHER SLABS SHALL BE MIX NO. 3 AIR ENTRAINED.
2. MANHOLE BASE SHALL BE BEDDED ON 6-INCH GRANULAR MATERIAL ON FIRM SUBGRADE.
3. EXCAVATION BELOW PIPES SHALL BE BACKFILLED WITH GRANULAR MATERIAL 1/3 OF WAY TO TOP OF PIPE.
4. CONNECTION BETWEEN MANHOLE WALL AND PIPE SHALL BE NON-SHRINK GROUT.
5. MANHOLE STEPS SHALL BE AS SPECIFIED ON DETAIL
6. MANHOLE COVER SHALL BE AS SHOWN ON DETAIL
7. PIPE JOINTS SHALL BE PROVIDED WITHIN 2' MAX. FROM OUTSIDE OF MANHOLE WALL
8. MANHOLE CHANNELS SHALL BE FORMED TO PROVIDE A SMOOTH TRANSITION BETWEEN PIPES. EXTEND BENCH TO FULL HEIGHT OF PIPE OPENING.
9. MANHOLE WALL THICKNESS SHALL BE AS SHOWN BELOW:

DEPTH BELOW MANHOLE COVER	WALL THICKNESS
TO 12'-0"	8"
12'-1" TO 18'-0"	12"
18'-1" TO 24'-0"	16"
GREATER THAN 24'-0"	SPECIAL DESIGN

REVISED	
DATE	BY

CARROLL COUNTY, MARYLAND
DEPARTMENT OF PUBLIC WORKS

[Signature] 4-12-94
DIRECTOR DATE

4'-0" BRICK MANHOLE
FOR USE WITH PIPES
24" AND SMALLER

PLATE
90

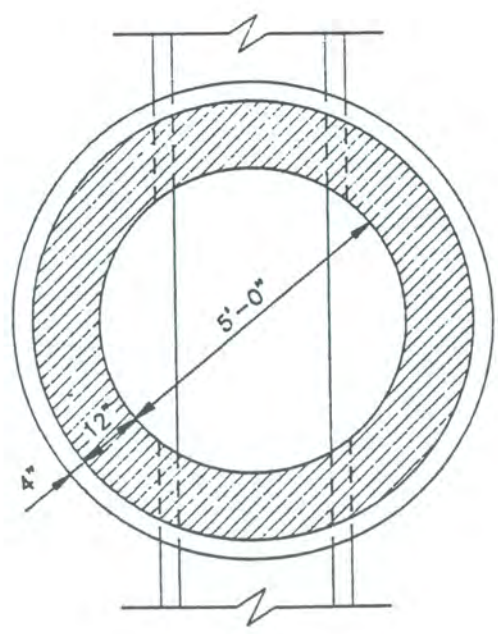
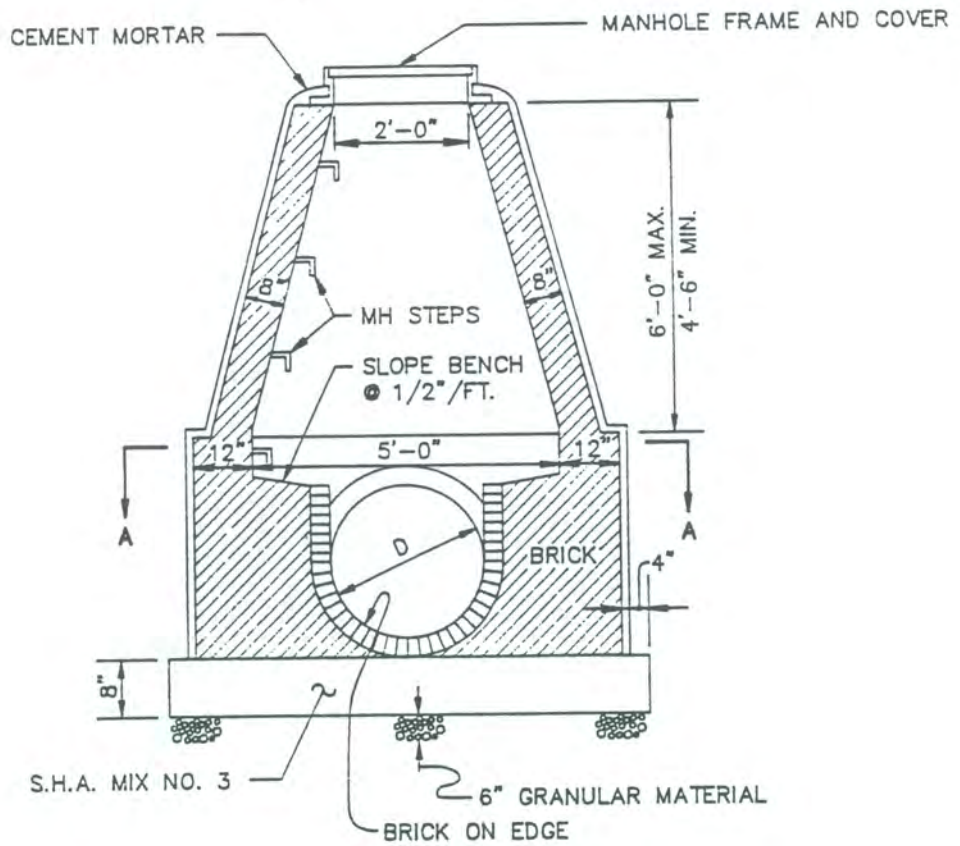

SECTION A-A

REVISED	
DATE	BY

PLATE

CARROLL COUNTY, MARYLAND
DEPARTMENT OF PUBLIC WORKS

[Signature] 4-12-94
DIRECTOR DATE

5'-0" BRICK MANHOLE FOR
USE WITH 27" TO 36" PIPE

SEE GENERAL NOTES APPLICABLE
TO ALL BRICK MANHOLES ON
DETAIL

#7 @ 6" O/C
EACH WAY,
BOTTOM.

ADDITIONAL #7 @ 6" O/C
AS SHOWN, BOTTOM

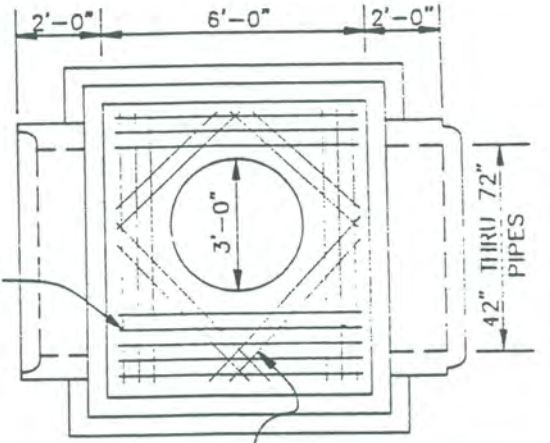

PLAN

12-INCH MIDDLE SLAB REINFORCING

MIDDLE SLAB SHALL BE A 12" PRECAST
CONCRETE SLAB, MIX NO.3, AIR ENTRAINED.

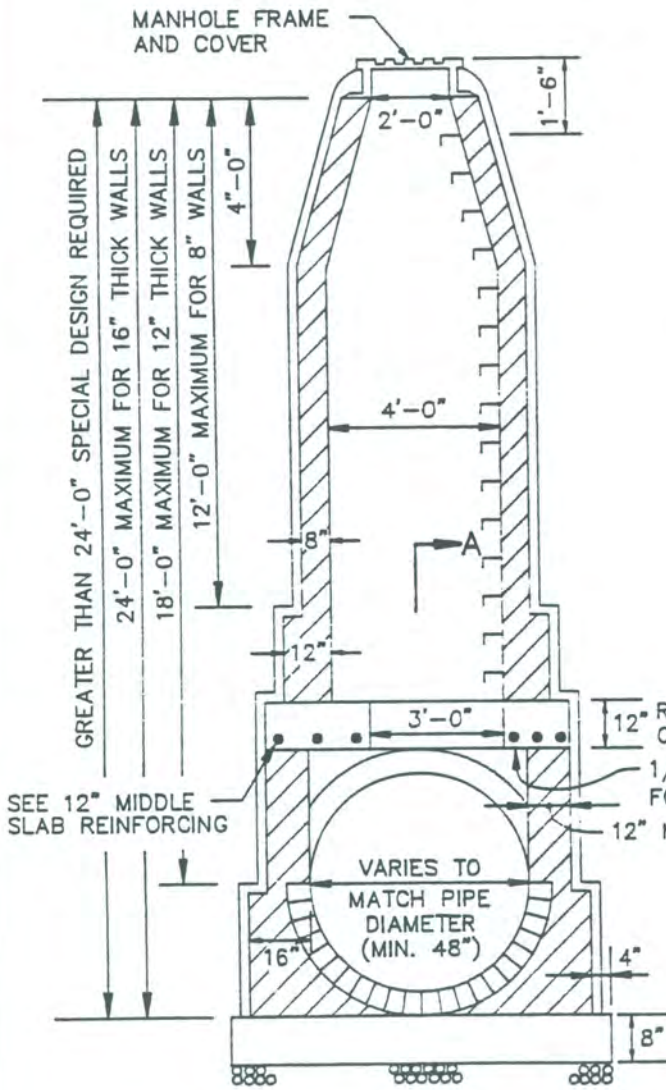

ELEVATION

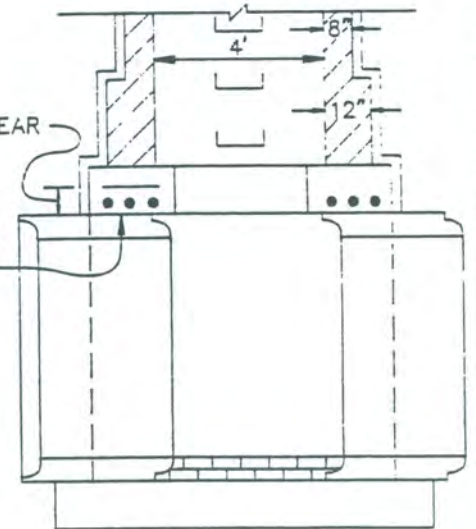

SECTION A-A

REVISED	
DATE	BY

CARROLL COUNTY, MARYLAND
DEPARTMENT OF PUBLIC WORKS

[Signature] 4-12-94
DIRECTOR DATE

BRICK MANHOLE FOR USE
WITH 42" THRU 72" PIPES

PLATE

92

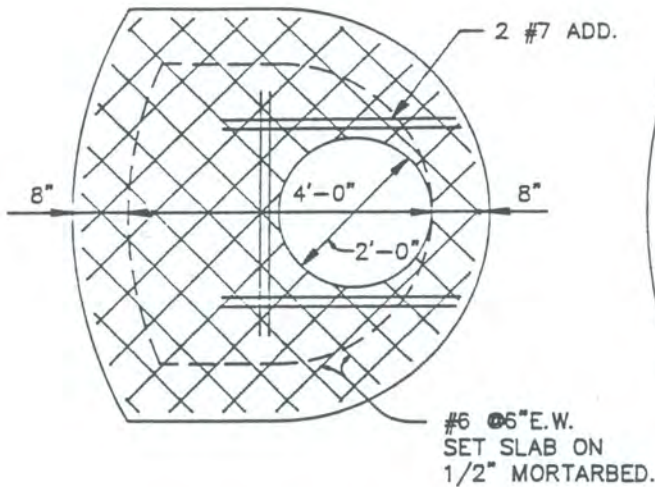

**SLAB REINFORCING
PLAN**

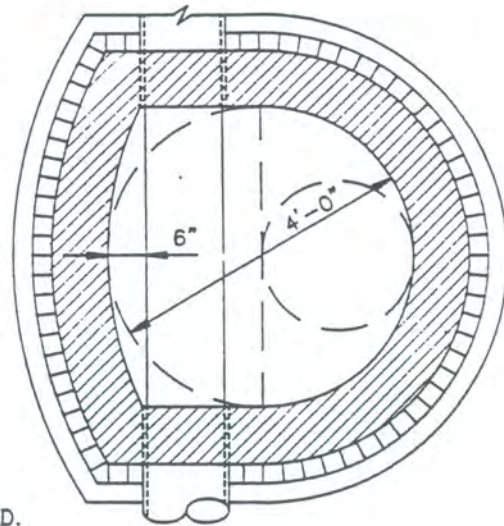

SECTION A-A

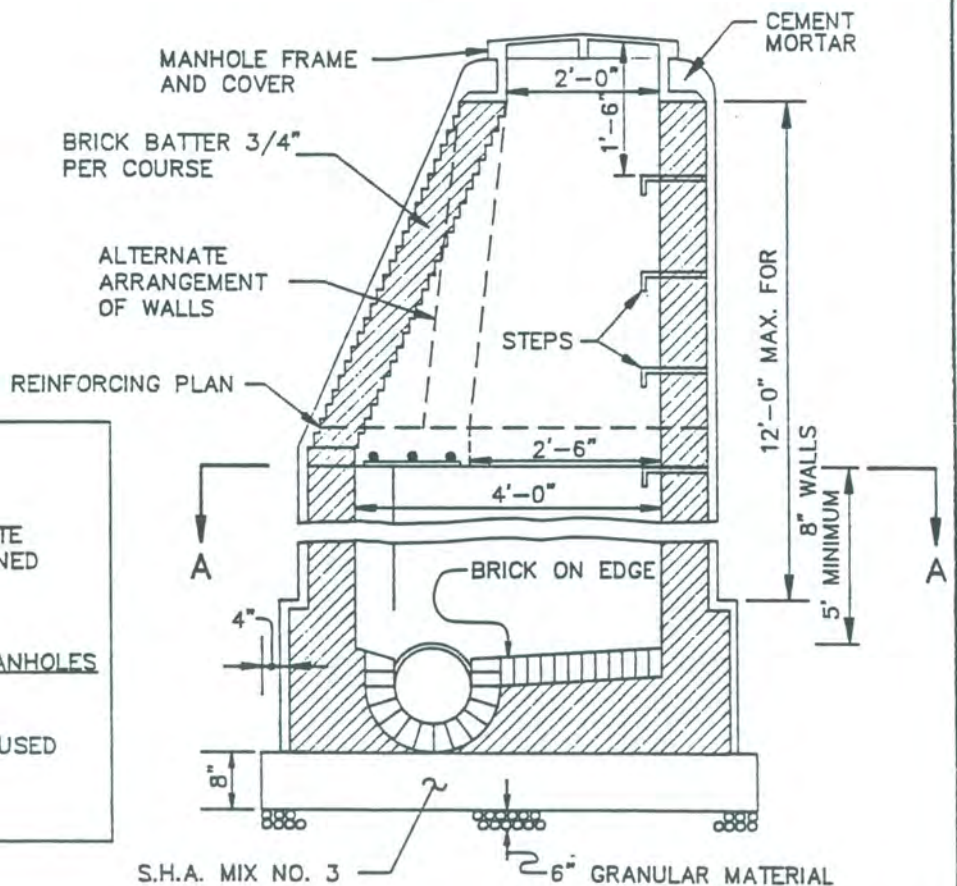

NOTES

1. IF USED, MIDDLE SLAB SHALL BE 8-INCH PRECAST CONCRETE SLAB, MIX NO. 3, AIR ENTRAINED CONCRETE.
2. SEE GENERAL NOTES APPLICABLE TO ALL BRICK MANHOLES ON DETAIL
3. MIDDLE SLAB SHALL NOT BE USED WITH LESS THAN 5 FEET TO TOP OF PIPE.

REVISED	
DATE	BY

CARROLL COUNTY, MARYLAND
DEPARTMENT OF PUBLIC WORKS

[Signature] 4-12-94
DIRECTOR DATE

BRICK MANHOLE WITH OFFSET
COVER FOR USE WITH
24" PIPES AND SMALLER

PLATE

93

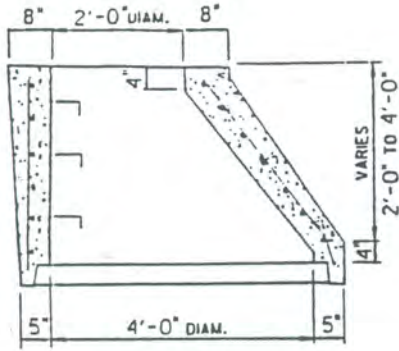

**ALTERNATE ECCENTRIC
CONE UNIT**

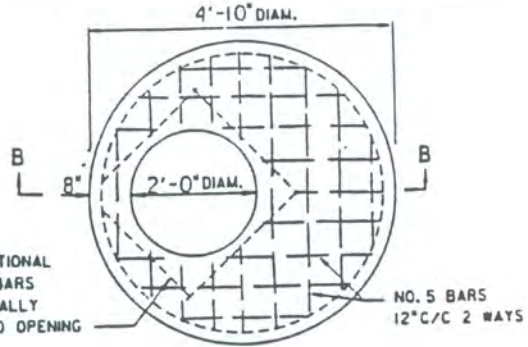

FLAT SLAB TOP
(SHOWN WITHOUT FRAME & COVER)

STANDARD TYPE A MANHOLE
FRAME & COVER SEE STD.

FRAME ANCHORAGE
SEE STD.

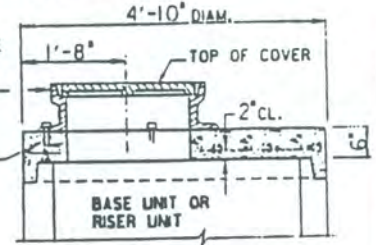

SECTION B-B

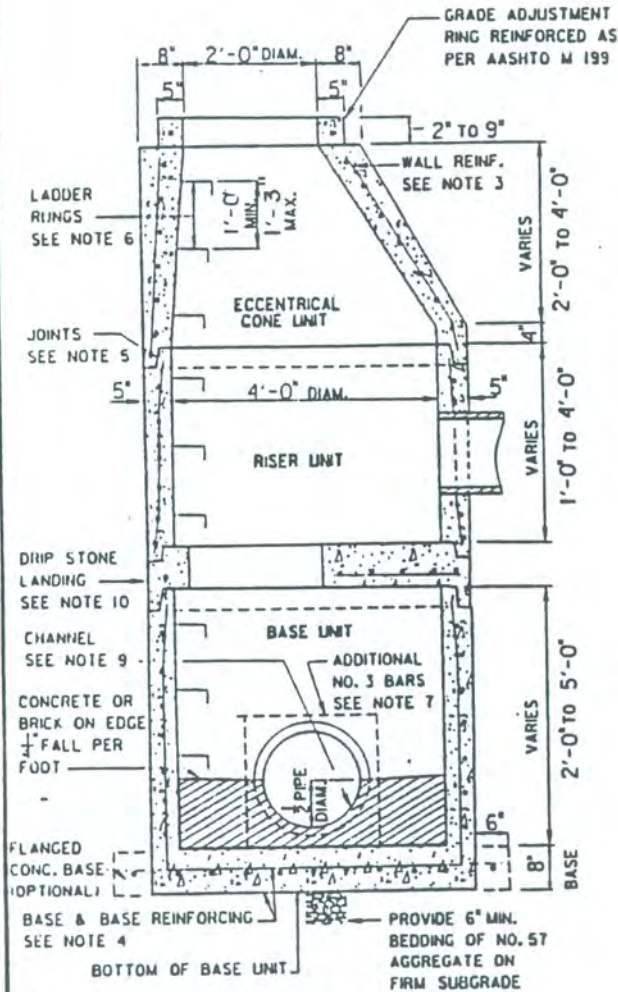

SECTION VIEW
(SHOWN WITHOUT FRAME & COVER)

NOTES:

1. MANHOLES SHALL BE CONSTRUCTED IN ACCORDANCE WITH AASHTO M 199.
2. CONCRETE SHALL BE MIX NO. 6 (4500 PSI).
3. WALL REINFORCEMENT FOR BASE UNITS, RISER UNITS AND ECCENTRIC CONE UNITS SHALL BE REINFORCEMENT BASE OR WELDED WIRE FABRIC WITH A MINIMUM AREA OF 0.2 IN.²/FT FOR THE 48" DIAMETER MANHOLES. WELDED WIRE FABRIC SHALL CONFORM TO ASTM A 185 AND A B2. REINFORCEMENT BARS SHALL MEET ASTM A 615, GRADE 60.
4. BASE REINFORCEMENT SHALL BE REINFORCEMENT BARS OR WELDED WIRE FABRIC WITH A MINIMUM AREA OF 0.14 IN.²/FT. THE BASE MAY BE CAST MONOLITHIC WITH THE BASE UNIT OR JOINTED PER MANUFACTURER'S DESIGN.
5. THE MANUFACTURER SHALL FORM MALE AND FEMALE ENDS OF JOINTS USING THEIR OWN DESIGN. THE JOINTS SHALL BE SEALED BY THE CONTRACTOR AND MADE WATERTIGHT USING (WHERE APPLICABLE) MORTAR, RUBBER O-RING GASKETS MEETING ASTM C 361 & C 443 OR FLEXIBLE PLASTIC GASKETS MEETING AASHTO M 198 TYPE B.
6. LADDER RUNGS SHALL BE INSTALLED IN VERTICAL ALIGNMENT AT 1'-3" MAXIMUM C/C. RUNG TYPES SHALL BE IN ACCORDANCE WITH CARROLL COUNTY STANDARDS. LADDER RUNGS SHALL BE INCIDENTAL TO THE COST OF THE MANHOLE.
7. WHEN THE DISTANCE BETWEEN MULTIPLE OPENINGS IN THE BASE UNIT OR ANY RISER UNIT IS LESS THAN 6" ADDITIONAL NO. 3 BARS ARE REQUIRED AROUND OPENINGS.
8. LIFT HOLES OR LIFT EYES SHALL BE PROVIDED IN EACH SECTION FOR HANDLING.
9. MIX NO. 2 CONCRETE OR BRICK CHANNEL SHALL BE PROVIDED IN THE FIELD AND SHALL SLOPE 2" PER FOOT TOWARD OUTLET OR AS DIRECTED BY THE ENGINEER.
10. THE DRIP STONE LANDING SHALL BE USED ONLY WHEN THERE ARE PIPES CONNECTED TO THE RISER UNITS. SEE PLATE 101 FOR DETAILS.
11. MINIMUM DEPTH PAYMENT PER EACH SHALL BE 3'-11" MEASURED FROM THE BOTTOM OF THE BASE UNIT TO THE TOP OF THE MANHOLE COVER. VERTICAL DEPTH PAYMENT PER LINEAR FOOT SHALL INCLUDE ALL DEPTHS IN EXCESS OF 3'-11". THE COST OF THE DRIP STONE LANDING, NO. 57 AGGREGATE, GROUT, SEALANT, AND ALL NECESSARY APPURTENANCES SHALL BE INCIDENTAL TO THE PRICE BID.

REVISED	
DATE	BY

CARROLL COUNTY, MARYLAND
DEPARTMENT OF PUBLIC WORKS

[Signature] 4-12-94
DIRECTOR DATE

48" DIAMETER PRECAST
MANHOLE FOR
PIPES 24" AND SMALLER

PLATE

94

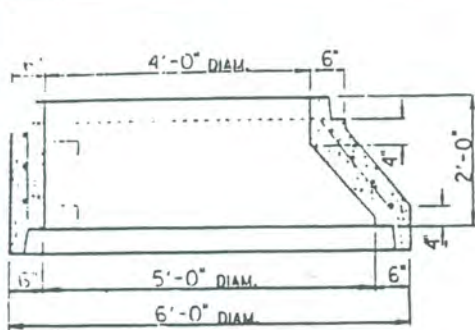

ECCENTRIC CONE REDUCER
(ALTERNATE FOR FLATTOP REDUCER)

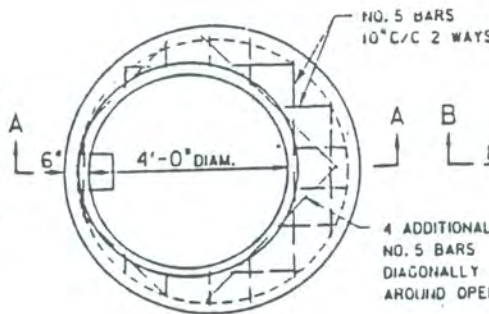

FLATTOP REDUCER

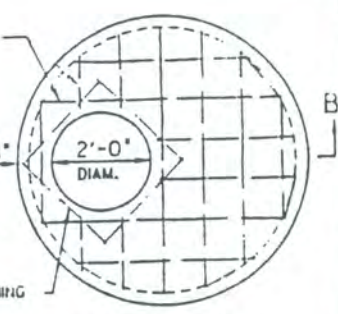

FLAT SLAB TOP
(SHOWN WITHOUT FRAME & COVER)

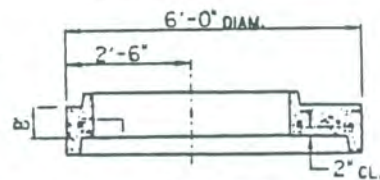

SECTION A-A

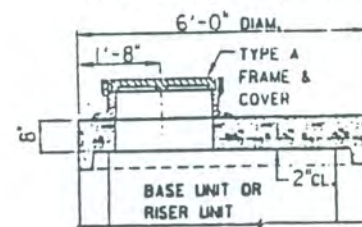

SECTION B-B

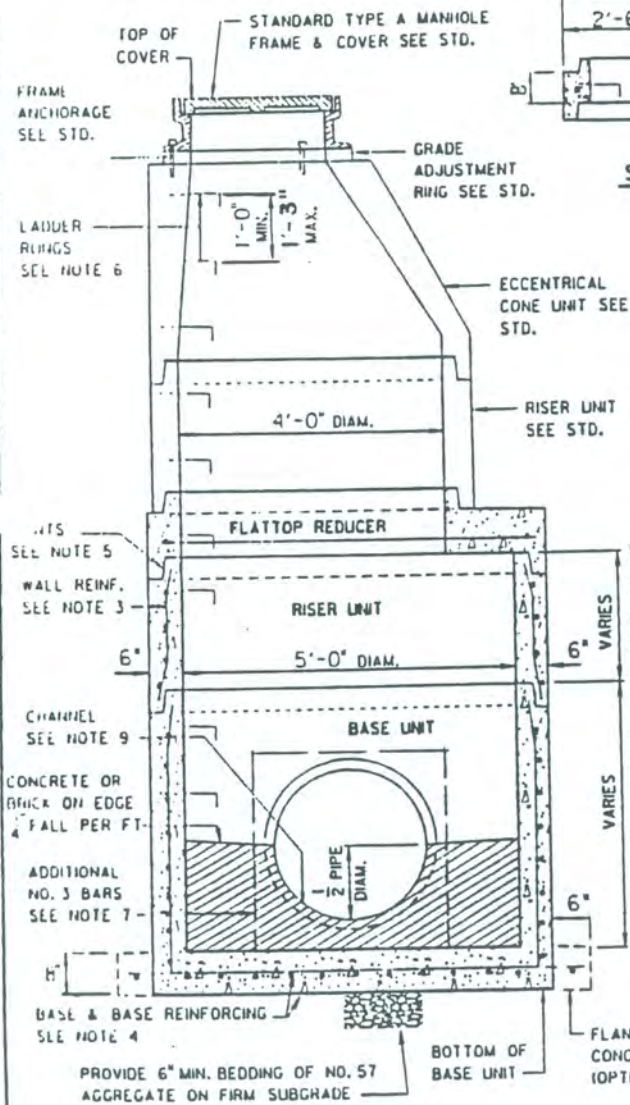

SECTION VIEW

NOTES:

1. MANHOLES SHALL BE CONSTRUCTED IN ACCORDANCE WITH AASHTO M 199.
2. CONCRETE SHALL BE MIX NO. 6 (4500 PSI).
3. WALL REINFORCEMENT FOR BASE UNITS, RISER UNITS AND ECCENTRIC CONE UNITS SHALL BE REINFORCEMENT BARS OR WELDED WIRE FABRIC WITH A MINIMUM AREA OF 0.15 IN.²/FT FOR THE 60" DIAMETER MANHOLES. WELDED WIRE FABRIC SHALL CONFORM TO ASTM A 185 AND A 82. REINFORCEMENT BARS SHALL MEET ASTM A 615, GRADE 60.
4. BASE REINFORCEMENT TO BE REINFORCEMENT BARS OR WELDED WIRE FABRIC WITH A MINIMUM AREA OF 0.17 IN.²/FT. THE BASE SHALL BE CAST MONOLITHIC WITH THE BASE UNIT OR JOINTED PER MANUFACTURER'S DESIGN.
5. THE MANUFACTURER SHALL FORM MALE AND FEMALE ENDS OF JOINTS USING THEIR OWN DESIGN. THE JOINTS SHALL BE SEALED BY THE CONTRACTOR AND MADE WATERTIGHT USING (WHERE APPLICABLE) MORTAR, RUBBER O-RING GASKETS MEETING ASTM C 361 AND C 443 OR FLEXIBLE PLASTIC GASKETS MEETING AASHTO M 198 TYPE B.
6. LADDER RUNGS SHALL BE INSTALLED IN VERTICAL ALIGNMENT AT 1'-3" MAXIMUM C/C. RUNG TYPES SHALL BE IN ACCORDANCE WITH CARROLL COUNTY STANDARDS. LADDER RUNGS SHALL BE INCIDENTAL TO THE COST OF THE MANHOLE.
7. WHEN THE DISTANCE BETWEEN MULTIPLE OPENINGS IN THE BASE UNIT OR ANY RISER UNIT IS LESS THAN 6" ADDITIONAL NO. 3 BARS ARE REQUIRED AROUND OPENINGS.
8. LIFT HOLES OR LIFT EYES SHALL BE PROVIDED IN EACH SECTION FOR HANDLING.
9. MIX NO. 2 CONCRETE OR BRICK CHANNEL SHALL BE PROVIDED IN THE FIELD AND SHALL SLOPE 2" PER FOOT TOWARD OUTLET OR AS DIRECTED BY THE ENGINEER.
10. THE DRIP STONE LANDING SHALL BE USED ONLY WHEN THERE ARE PIPES CONNECTED TO THE RISER UNITS. SEE PLATE 101 FOR DETAILS.
11. MINIMUM DEPTH PAYMENT PER EACH SHALL BE 5'-1" MEASURED FROM THE BOTTOM OF THE BASE UNIT TO THE TOP OF THE MANHOLE COVER. VERTICAL DEPTH PAYMENT PER LINEAR FOOT SHALL INCLUDE ALL DEPTHS IN EXCESS OF 5'-1". THE COST OF THE DRIP STONE LANDING, NO. 57 AGGREGATE, GROUT, SEALANT, AND ALL NECESSARY APPURTENANCES SHALL BE INCIDENTAL TO THE PRICE BID.

REVISED

DATE BY

PLATE

95

CARROLL COUNTY, MARYLAND
DEPARTMENT OF PUBLIC WORKS

60" DIAMETER PRECAST
MANHOLE FOR 27" TO
36" PIPES

DIRECTOR

DATE

[Signature] 4-12-94

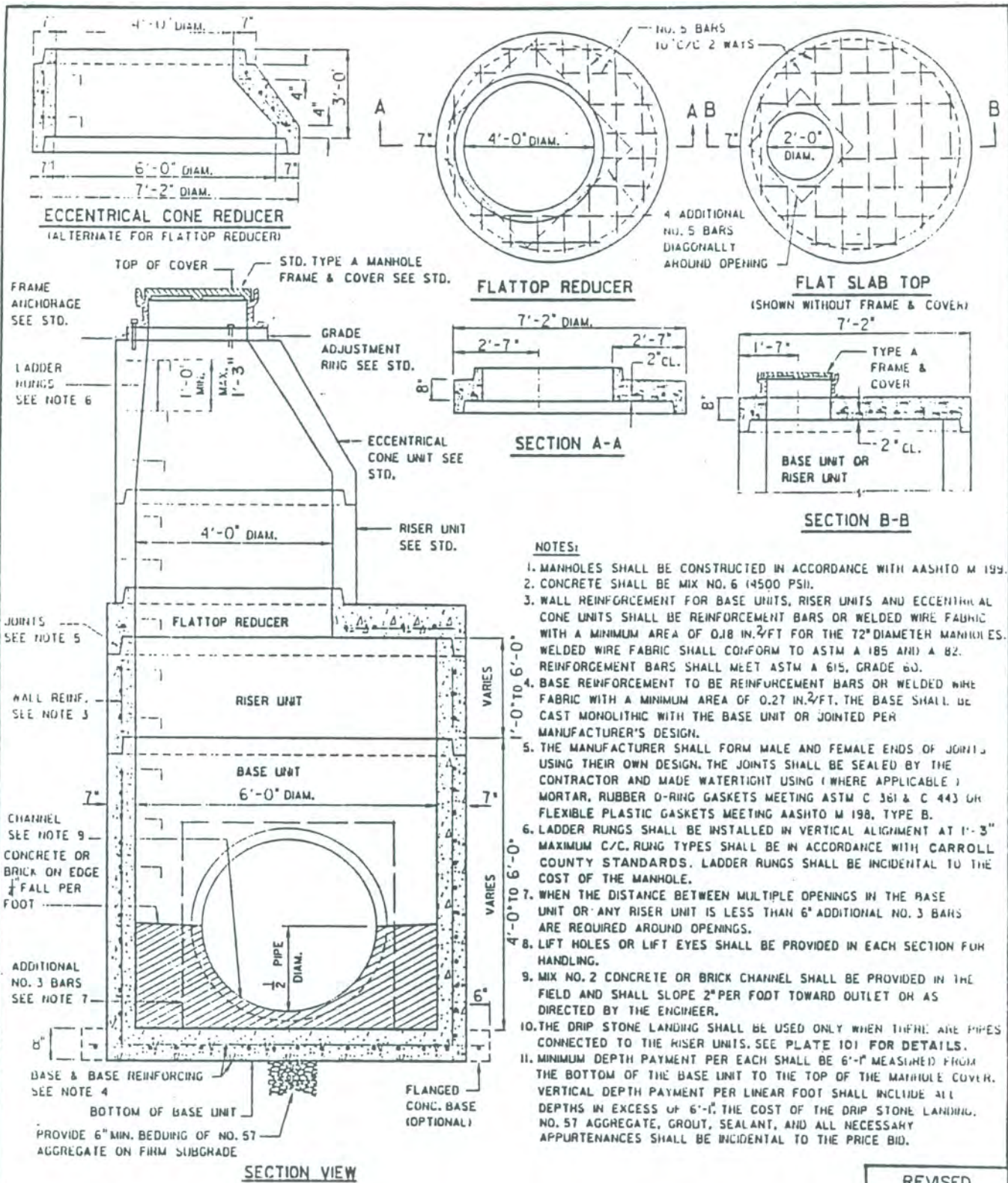

- NOTES:**
1. MANHOLES SHALL BE CONSTRUCTED IN ACCORDANCE WITH AASHTO M 199.
 2. CONCRETE SHALL BE MIX NO. 6 (4500 PSII).
 3. WALL REINFORCEMENT FOR BASE UNITS, RISER UNITS AND ECCENTRICAL CONE UNITS SHALL BE REINFORCEMENT BARS OR WELDED WIRE FABRIC WITH A MINIMUM AREA OF 0.18 IN.²/FT FOR THE 72" DIAMETER MANHOLES. WELDED WIRE FABRIC SHALL CONFORM TO ASTM A 185 AND A 82. REINFORCEMENT BARS SHALL MEET ASTM A 615, GRADE 60.
 4. BASE REINFORCEMENT TO BE REINFORCEMENT BARS OR WELDED WIRE FABRIC WITH A MINIMUM AREA OF 0.27 IN.²/FT. THE BASE SHALL BE CAST MONOLITHIC WITH THE BASE UNIT OR JOINTED PER MANUFACTURER'S DESIGN.
 5. THE MANUFACTURER SHALL FORM MALE AND FEMALE ENDS OF JOINTS USING THEIR OWN DESIGN. THE JOINTS SHALL BE SEALED BY THE CONTRACTOR AND MADE WATERTIGHT USING (WHERE APPLICABLE) MORTAR, RUBBER O-RING GASKETS MEETING ASTM C 361 & C 443 OR FLEXIBLE PLASTIC GASKETS MEETING AASHTO M 198, TYPE B.
 6. LADDER RUNGS SHALL BE INSTALLED IN VERTICAL ALIGNMENT AT 1'-3" MAXIMUM C/C. RUNG TYPES SHALL BE IN ACCORDANCE WITH CARROLL COUNTY STANDARDS. LADDER RUNGS SHALL BE INCIDENTAL TO THE COST OF THE MANHOLE.
 7. WHEN THE DISTANCE BETWEEN MULTIPLE OPENINGS IN THE BASE UNIT OR ANY RISER UNIT IS LESS THAN 6" ADDITIONAL NO. 3 BARS ARE REQUIRED AROUND OPENINGS.
 8. LIFT HOLES OR LIFT EYES SHALL BE PROVIDED IN EACH SECTION FOR HANDLING.
 9. MIX NO. 2 CONCRETE OR BRICK CHANNEL SHALL BE PROVIDED IN THE FIELD AND SHALL SLOPE 2" PER FOOT TOWARD OUTLET OR AS DIRECTED BY THE ENGINEER.
 10. THE DRIP STONE LANDING SHALL BE USED ONLY WHEN THERE ARE PIPES CONNECTED TO THE RISER UNITS. SEE PLATE 101 FOR DETAILS.
 11. MINIMUM DEPTH PAYMENT PER EACH SHALL BE 6'-0" MEASURED FROM THE BOTTOM OF THE BASE UNIT TO THE TOP OF THE MANHOLE COVER. VERTICAL DEPTH PAYMENT PER LINEAR FOOT SHALL INCLUDE ALL DEPTHS IN EXCESS OF 6'-0". THE COST OF THE DRIP STONE LANDING, NO. 57 AGGREGATE, GROUT, SEALANT, AND ALL NECESSARY APPURTENANCES SHALL BE INCIDENTAL TO THE PRICE BID.

REVISED	
DATE	BY

CARROLL COUNTY, MARYLAND
DEPARTMENT OF PUBLIC WORKS

Carroll 4-12-94
DIRECTOR DATE

72" DIAMETER PRECAST
MANHOLE FOR 42" AND
48" PIPES

PLATE
96

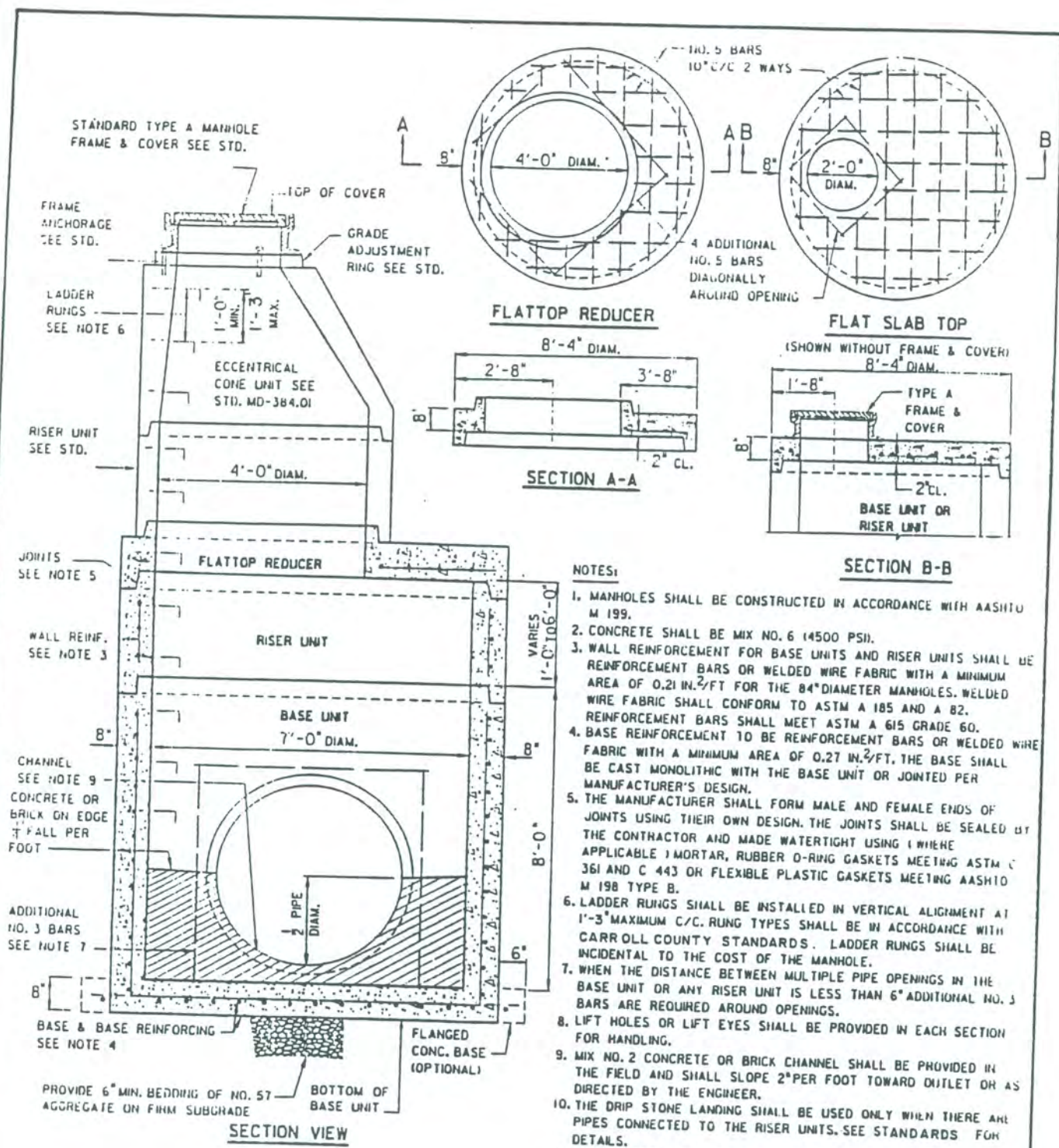

- NOTES:**
1. MANHOLES SHALL BE CONSTRUCTED IN ACCORDANCE WITH AASHTO M 199.
 2. CONCRETE SHALL BE MIX NO. 6 (4500 PSI).
 3. WALL REINFORCEMENT FOR BASE UNITS AND RISER UNITS SHALL USE REINFORCEMENT BARS OR WELDED WIRE FABRIC WITH A MINIMUM AREA OF 0.21 IN.²/FT FOR THE 84" DIAMETER MANHOLES. WELDED WIRE FABRIC SHALL CONFORM TO ASTM A 185 AND A 82. REINFORCEMENT BARS SHALL MEET ASTM A 615 GRADE 60.
 4. BASE REINFORCEMENT TO BE REINFORCEMENT BARS OR WELDED WIRE FABRIC WITH A MINIMUM AREA OF 0.27 IN.²/FT. THE BASE SHALL BE CAST MONOLITHIC WITH THE BASE UNIT OR JOINTED PER MANUFACTURER'S DESIGN.
 5. THE MANUFACTURER SHALL FORM MALE AND FEMALE ENDS OF JOINTS USING THEIR OWN DESIGN. THE JOINTS SHALL BE SEALED BY THE CONTRACTOR AND MADE WATERTIGHT USING (WHICHE APPLICABLE) MORTAR, RUBBER O-RING GASKETS MEETING ASTM C 361 AND C 443 OR FLEXIBLE PLASTIC GASKETS MEETING AASHTO M 198 TYPE B.
 6. LADDER RUNGS SHALL BE INSTALLED IN VERTICAL ALIGNMENT AT 1'-3" MAXIMUM C/C. RUNG TYPES SHALL BE IN ACCORDANCE WITH CARROLL COUNTY STANDARDS. LADDER RUNGS SHALL BE INCIDENTAL TO THE COST OF THE MANHOLE.
 7. WHEN THE DISTANCE BETWEEN MULTIPLE PIPE OPENINGS IN THE BASE UNIT OR ANY RISER UNIT IS LESS THAN 6" ADDITIONAL NO. 3 BARS ARE REQUIRED AROUND OPENINGS.
 8. LIFT HOLES OR LIFT EYES SHALL BE PROVIDED IN EACH SECTION FOR HANDLING.
 9. MIX NO. 2 CONCRETE OR BRICK CHANNEL SHALL BE PROVIDED IN THE FIELD AND SHALL SLOPE 2" PER FOOT TOWARD OUTLET OR AS DIRECTED BY THE ENGINEER.
 10. THE DRIP STONE LANDING SHALL BE USED ONLY WHEN THERE ARE PIPES CONNECTED TO THE RISER UNITS. SEE STANDARDS FOR DETAILS.
 11. MINIMUM DEPTH PAYMENT PER EACH SHALL BE 10'-1" MEASURED FROM THE BOTTOM OF THE BASE UNIT TO THE TOP OF THE MANHOLE COVER. VERTICAL DEPTH PAYMENT PER LINEAR FOOT SHALL INCLUDE ALL DEPTHS IN EXCESS OF 10'-1". THE COST OF THE DRIP STONE LANDING, NO. 57 AGGREGATE, GROUT, SEALANT, AND ALL NECESSARY APPURTENANCES SHALL BE INCIDENTAL TO THE PRICE BID.

CARROLL COUNTY, MARYLAND
DEPARTMENT OF PUBLIC WORKS

[Signature] 4-12-94
DIRECTOR DATE

84" DIAMETER PRECAST
MANHOLE FOR 54" AND
60" PIPES

REVISED
PLATE
97

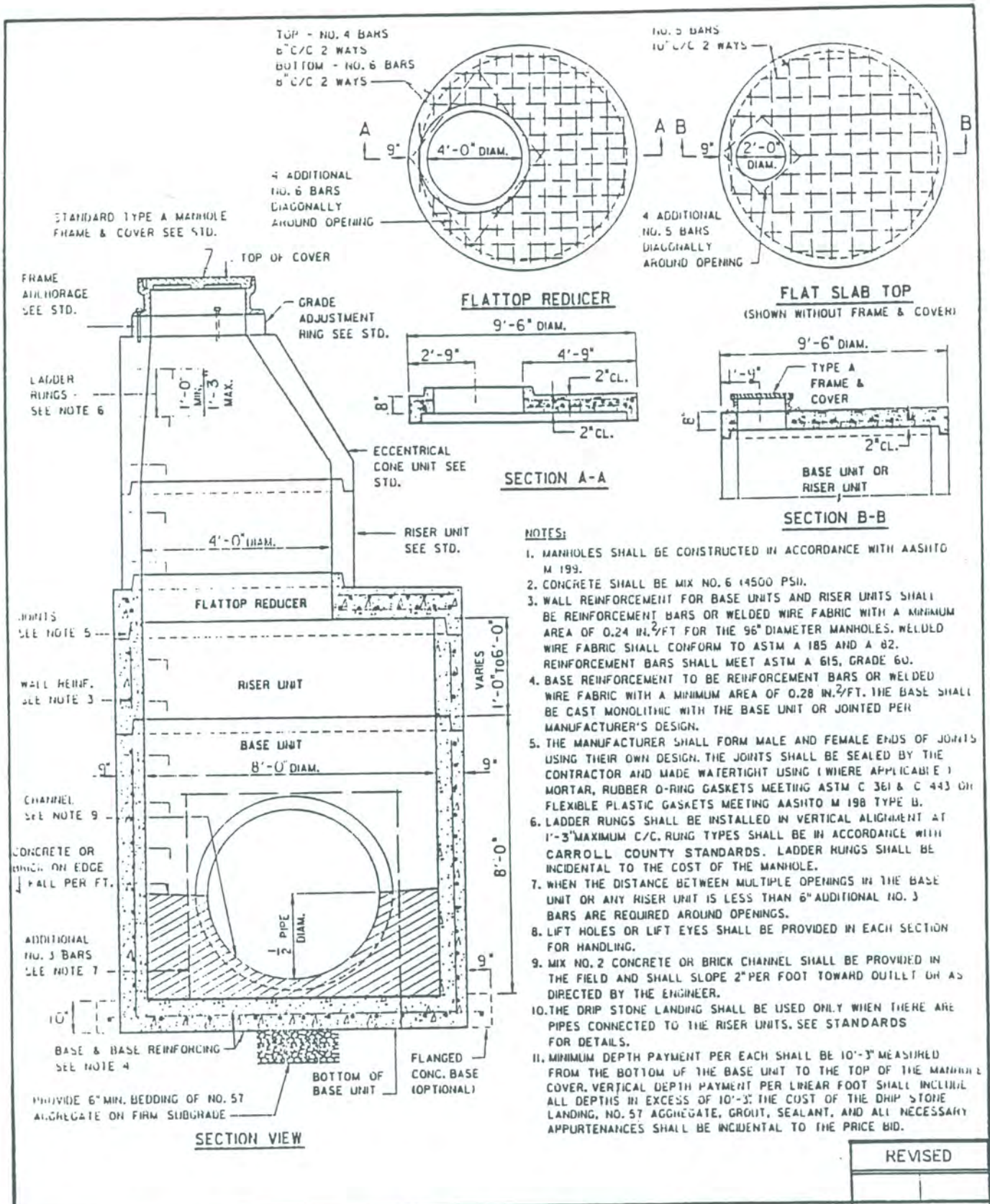

CARROLL COUNTY, MARYLAND
DEPARTMENT OF PUBLIC WORKS

Handwritten Signature 4-12-94
DIRECTOR DATE

96" DIAMETER PRECAST
MANHOLE FOR 72" PIPES

REVISED

PLATE

98

STANDARD TYPE A MANHOLE
FRAME & COVER SEE STD.

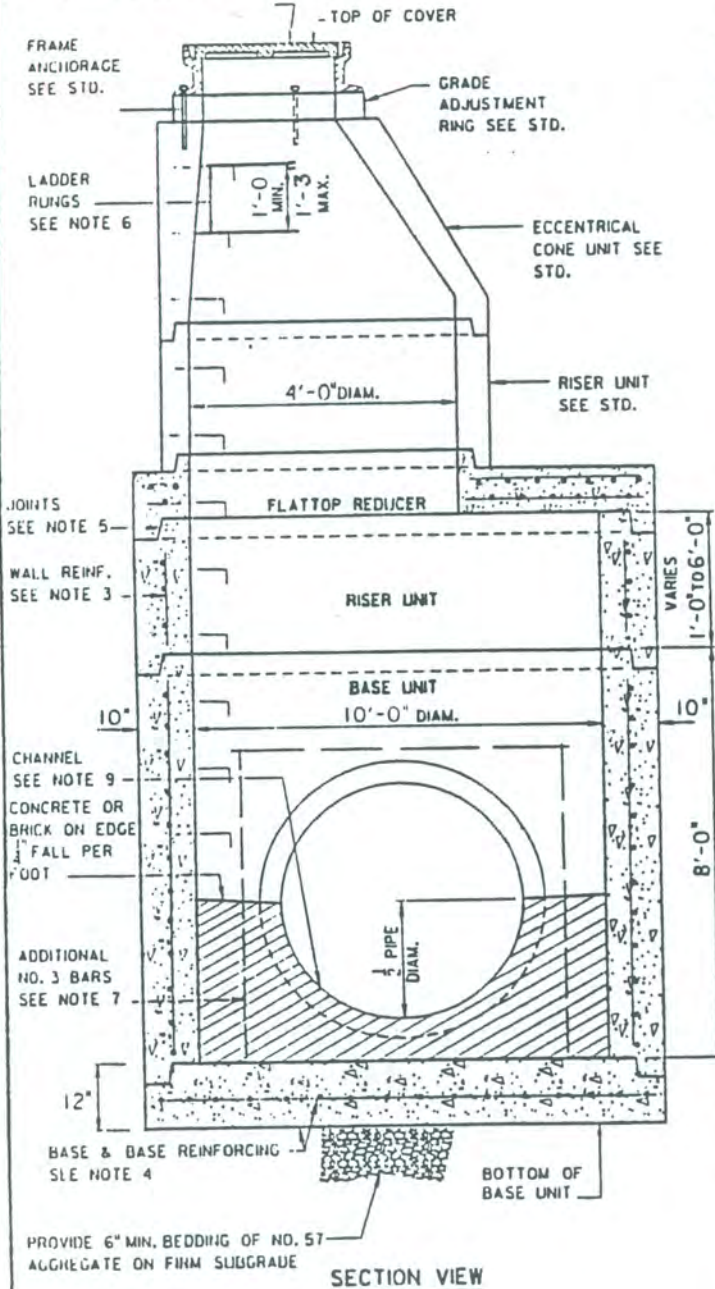

SECTION VIEW

TOP - NO. 4 BARS
6" C/C 2 WAYS
BOTTOM - NO. 5 BARS
6" C/C 2 WAYS

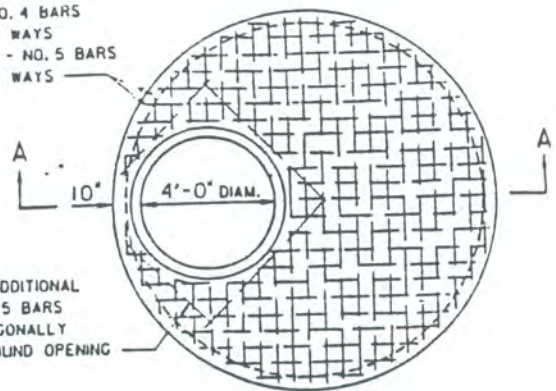

FLATTOP REDUCER

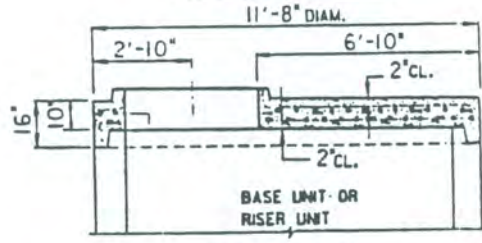

SECTION A-A

NOTES:

1. MANHOLES SHALL BE CONSTRUCTED IN ACCORDANCE WITH AASHTO M 199.
2. CONCRETE SHALL BE MIX NO. 6 (4500 PSI).
3. WALL REINFORCEMENT FOR BASE UNITS AND RISER UNITS SHALL BE REINFORCEMENT BARS OR WELDED WIRE FABRIC WITH A MINIMUM AREA OF 0.30 IN.²/FT FOR THE 120" DIAMETER MANHOLES. WELDED WIRE FABRIC SHALL CONFORM TO ASTM A 185 AND A 82. REINFORCEMENT BARS SHALL MEET ASTM A 615, GRADE 60.
4. BASE REINFORCEMENT TO BE REINFORCEMENT BARS OR WELDED WIRE FABRIC WITH A MINIMUM AREA OF 0.39 IN.²/FT. THE BASE SHALL BE CAST MONOLITHIC WITH THE BASE UNIT OR JOINTED PER THE MANUFACTURER'S DESIGN.
5. THE MANUFACTURER SHALL FORM MALE AND FEMALE ENDS OF JOINTS USING THEIR OWN DESIGN. THE JOINTS SHALL BE SEALED BY THE CONTRACTOR AND MADE WATERTIGHT USING (WHERE APPLICABLE) MORTAR, RUBBER O-RING GASKETS MEETING ASTM C 361 & C 443 OR FLEXIBLE PLASTIC GASKETS MEETING AASHTO M 198 TYPE B.
6. LADDER RUNGS SHALL BE INSTALLED IN VERTICAL ALIGNMENT AT 1'-3" MAXIMUM C/C. RUNG TYPES SHALL BE IN ACCORDANCE WITH CARROLL COUNTY STANDARDS. LADDER RUNGS SHALL BE INCIDENTAL TO THE COST OF THE MANHOLE.
7. WHEN THE DISTANCE BETWEEN MULTIPLE OPENINGS IN THE BASE UNIT OR ANY RISER UNIT IS LESS THAN 6" ADDITIONAL NO. 3 BARS ARE REQUIRED AROUND OPENINGS.
8. LIFT HOLES OR LIFT EYES SHALL BE PROVIDED IN EACH SECTION FOR HANDLING.
9. MIX NO. 2 CONCRETE OR BRICK CHANNEL SHALL BE PROVIDED IN THE FIELD AND SHALL SLOPE 2" PER FOOT TOWARD OUTLET OR AS DIRECTED BY THE ENGINEER.
10. THE DRIP STONE LANDING SHALL BE USED ONLY WHEN THERE ARE PIPES CONNECTED TO THE RISER UNITS. SEE STANDARDS FOR DETAILS.
11. MINIMUM DEPTH PAYMENT PER EACH SHALL BE 10'-7" MEASURED FROM THE BOTTOM OF THE BASE UNIT TO THE TOP OF THE MANHOLE COVER. VERTICAL DEPTH PAYMENT PER LINEAR FOOT SHALL INCLUDE ALL DEPTHS IN EXCESS OF 10'-7". THE COST OF THE DRIP STONE LANDING, NO. 57 AGGREGATE, GROUT, SEALANT, AND ALL APPURTENANCES SHALL BE INCIDENTAL TO THE PRICE BID.

REVISED	
DATE	BY

PLATE

CARROLL COUNTY, MARYLAND
DEPARTMENT OF PUBLIC WORKS

W. St. ... 4-12-94
DIRECTOR DATE

120" DIAMETER PRECAST
MANHOLE FOR 78" TO
84" PIPES

99

3- $\frac{1}{2}$ " \varnothing HEX HEAD BOLTS
WITH THREADED INSERTS
OR
3- $\frac{1}{2}$ " \varnothing THREADED STUDS
WITH HEX HEAD NUTS.
STUDS TO BE GROUTED
IN PLACE OR ANCHORED
WITH A CONCRETE COMPATIBLE
CHEMICAL ADHESIVE.

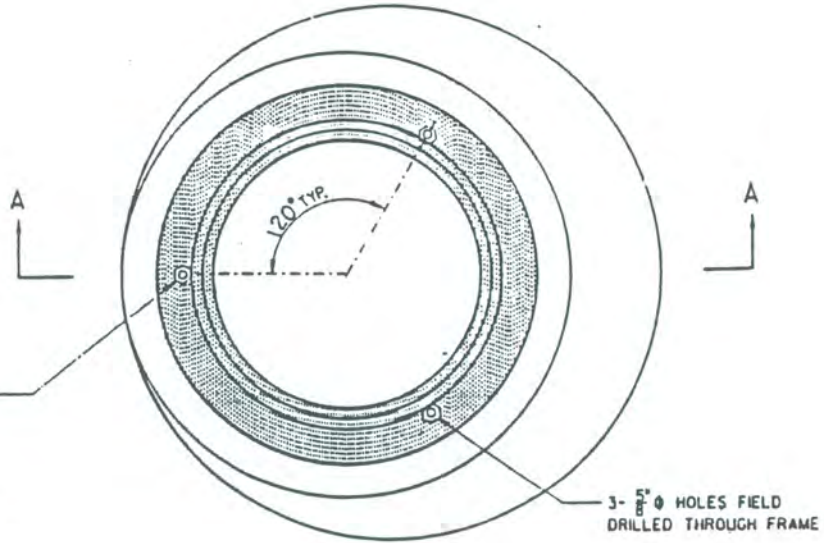

PLAN

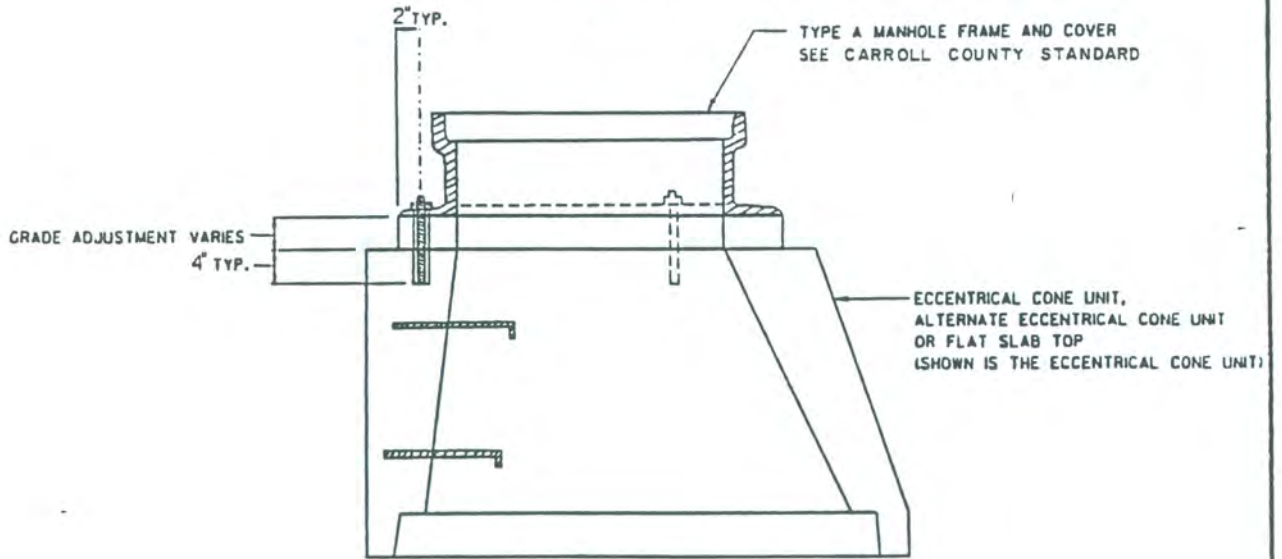

SECTION A-A

REVISED	
DATE	BY

CARROLL COUNTY, MARYLAND
DEPARTMENT OF PUBLIC WORKS

W. S. ... 4-12-94
DIRECTOR DATE

FRAME ANCHORAGE FOR
PRECAST MANHOLES

PLATE

100

FLAT SLAB TOP
(OR ECCENTRICAL
CONE UNIT)

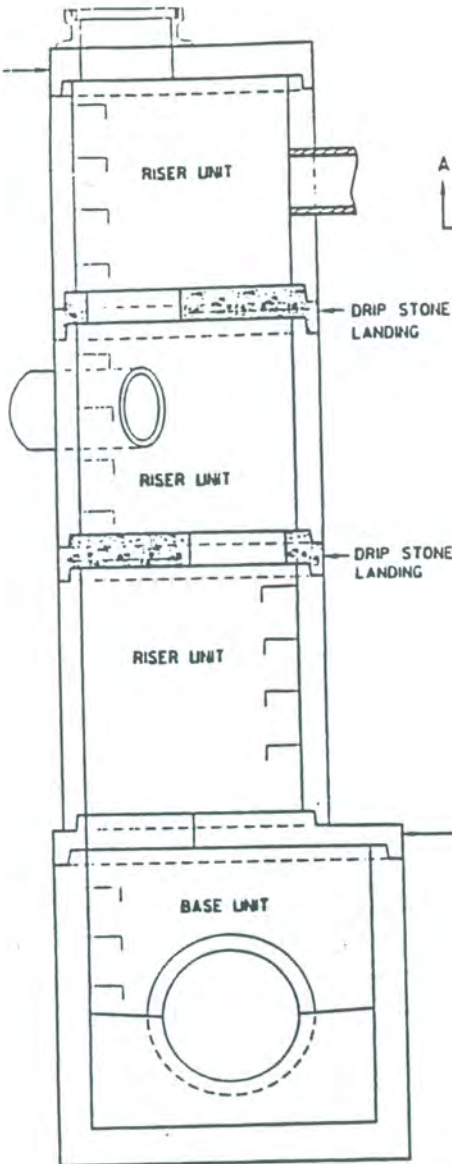

METHOD OF PLACING DRIP STONE LANDINGS

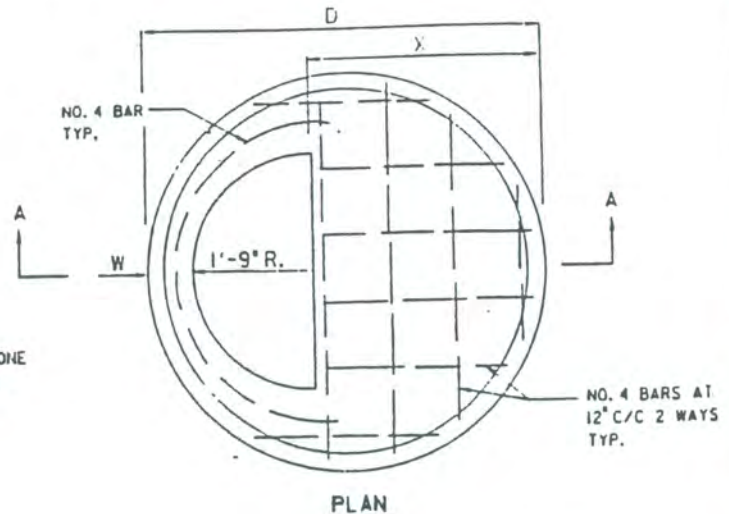

PLAN

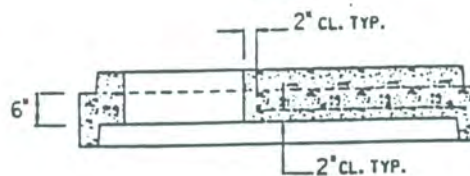

SECTION A-A
DRIP STONE LANDING

SEE C. CO. STD. FOR PRECAST COMBINATION FLATTOP REDUCER AND DRIP STONE LANDING FOR 60" TO 120" DIAMETER MANHOLES AND STANDARD FOR PRECAST COMBINATION ECCENTRICAL CONE REDUCER AND DRIP STONE LANDING FOR 60" AND 72" DIAMETER MANHOLES. OTHERWISE USE 48" DIAMETER DRIP STONE LANDING ON THIS SHEET.

PRECAST MANHOLE DIAMETER	DRIP STONE DIMENSIONS		
	D	W	X
48"	4'-10"	8"	2'-5"
60"	6'-0"	8"	3'-7"
72"	7'-2"	8"	4'-9"
84"	8'-4"	8"	5'-11"
96"	9'-6"	9"	7'-0"
120"	11'-8"	10"	9'-1"

NOTES:

1. THE DRIP STONE LANDING SHALL BE USED ONLY WHEN THERE ARE PIPES CONNECTED TO THE RISER UNITS.
2. CONCRETE SHALL BE MIX NO. 6 (4500 PSI).
3. REINFORCEMENT SHALL MEET ASTM A 615 GRADE 60.
4. THE MANUFACTURER SHALL FORM MALE AND FEMALE ENDS OF JOINTS USING THEIR OWN DESIGN.
5. LIFT EYES SHALL BE PROVIDED FOR HANDLING.
6. COST FOR THE DRIP STONE LANDING IS INCIDENTAL TO THE COST OF THE MANHOLE.

REVISED	
DATE	BY

CARROLL COUNTY, MARYLAND
DEPARTMENT OF PUBLIC WORKS

[Signature] 4-12-94
DIRECTOR DATE

PRECAST DRIP STONE
LANDING DETAILS FOR 48"
TO 120" DIAMETER
MANHOLES.

PLATE

101

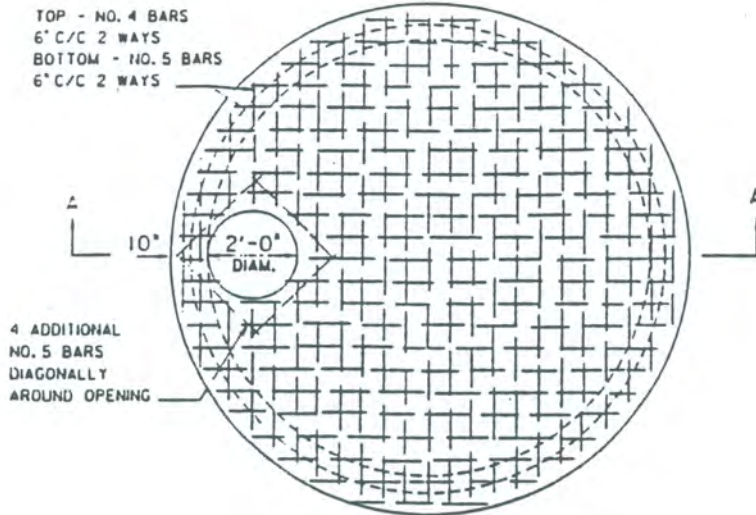

PLAN

(FRAME AND COVER NOT SHOWN)

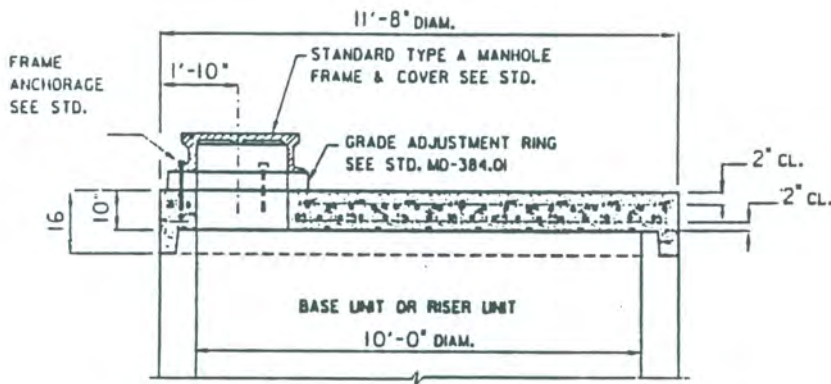

SECTION A-A

NOTES:

1. CONCRETE SHALL BE MIX NO. 6 (4500 PSI)
2. THE MANUFACTURER SHALL FORM MALE AND FEMALE ENDS OF JOINTS USING THEIR OWN DESIGN.
3. LIFT EYES SHALL BE PROVIDED FOR HANDLING.
4. COST FOR THE PRECAST FLAT SLAB TOP IS INCIDENTAL TO THE COST OF THE 120" PRECAST MANHOLE.
5. FOR USE WITH THE 120" DIAMETER PRECAST MANHOLE, SEE STANDARD NO.

REVISED	
DATE	BY

CARROLL COUNTY, MARYLAND
DEPARTMENT OF PUBLIC WORKS

Carol C. ... 4-12-94
DIRECTOR DATE

PRECAST FLAT SLAB TOP
FOR 120" DIAMETER
PRECAST MANHOLE

PLATE

102

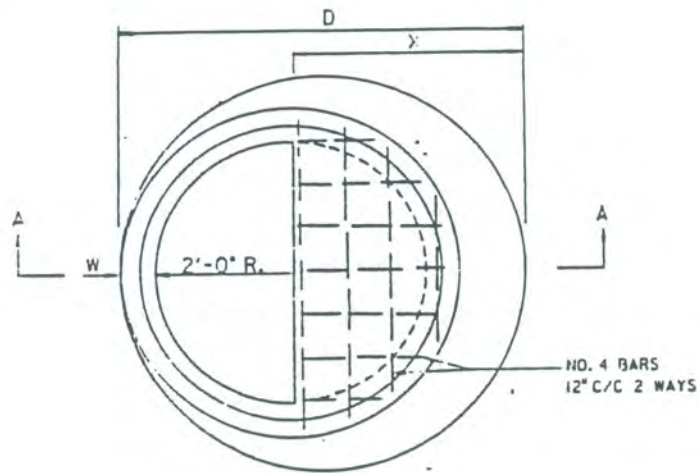

PLAN

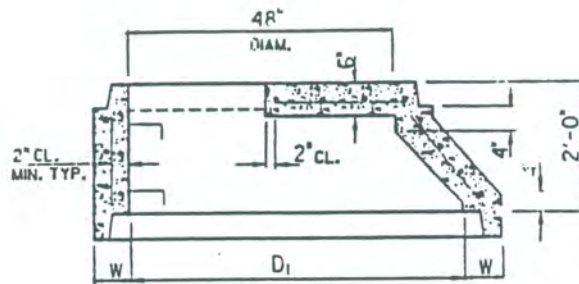

SECTION A-A

PRECAST MANHOLE DIAMETER	DIMENSIONS			
	D	D ₁	W	X
60"	6'-0"	5'-0"	6"	3'-6"
72"	7'-2"	6'-0"	7"	4'-7"

NOTES:

1. THE COMBINATION ECCENTRIC CONE REDUCER AND DRIP STONE LANDING SHALL BE USED ONLY WHEN THERE ARE PIPES CONNECTED TO THE RISER UNITS. SEE CARROLL COUNTY PLATE No. 101 FOR PLACEMENT.
2. CONCRETE SHALL BE MIX NO. 6 (4500 PSI).
3. REINFORCEMENT SHALL BE REINFORCING BARS OR WELDED WIRE FABRIC WITH A MINIMUM AREA OF 0.15 IN.²/FT FOR THE 60" DIAMETER CONE UNIT AND 0.18 IN.²/FT FOR THE 72" DIAMETER CONE UNIT.
4. THE MANUFACTURER SHALL FORM MALE AND FEMALE ENDS OF JOINTS USING THEIR OWN DESIGN.
5. LIFT EYES SHALL BE PROVIDED FOR HANDLING.
6. COST FOR THE COMBINATION ECCENTRIC CONE REDUCER AND DRIP STONE LANDING IS INCIDENTAL TO THE COST OF THE MANHOLE.

REVISED	
DATE	BY

CARROLL COUNTY, MARYLAND
DEPARTMENT OF PUBLIC WORKS

[Signature] 4-12-94
DIRECTOR DATE

PRECAST COMBINATION
FLAT TOP REDUCER AND DRIP
STONE LANDING FOR 60" TO
72" DIAMETER MANHOLES

PLATE

103

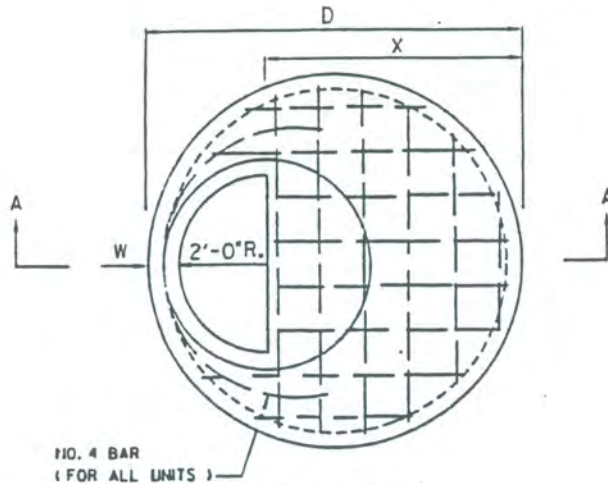

NO. 4 BAR
(FOR ALL UNITS)

PLAN

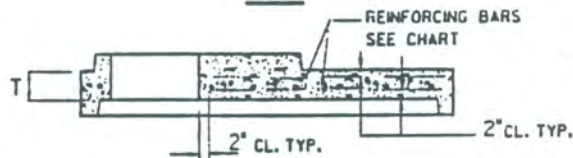

SECTION A-A

PRECAST MANHOLE DIAMETER	DIMENSIONS				REINFORCING BARS PLACED 2 WAYS	
	D	T	W	X	TOP LAYER	BOTTOM LAYER
60"	6'-0"	5"	6"	3'-6"	N/A	NO. 5 AT 10" C/C
72"	7'-2"	6"	7"	4'-7"	N/A	NO. 5 AT 10" C/C
84"	8'-4"	7"	8"	5'-8"	N/A	NO. 5 AT 10" C/C
96"	9'-6"	8"	9"	6'-9"	NO. 4 AT 8" C/C	NO. 6 AT 8" C/C
120"	11'-8"	9"	10"	8'-10"	NO. 4 AT 6" C/C	NO. 5 AT 6" C/C

NOTES:

1. THE COMBINATION FLATTOP REDUCER DRIP STONE LANDING SHALL BE USED ONLY WHEN THERE ARE PIPES CONNECTED TO THE RISER UNITS. SEE SEE CARROLL COUNTY PLATE No. 101 FOR PLACEMENT.
2. CONCRETE SHALL BE MIX NO. 6 (4500 PSI).
3. REINFORCEMENT SHALL MEET ASTM A 615 GRADE 60.
4. THE MANUFACTURER SHALL FORM MALE AND FEMALE ENDS OF JOINTS USING THEIR OWN DESIGN.
5. LIFT EYES SHALL BE PROVIDED FOR HANDLING.
6. COST FOR THE COMBINATION FLATTOP REDUCER AND DRIP STONE LANDING IS INCIDENTAL TO THE COST OF THE MANHOLE.

REVISED	
DATE	BY

CARROLL COUNTY, MARYLAND
DEPARTMENT OF PUBLIC WORKS

[Signature] 4-12-94
DIRECTOR DATE

PRECAST COMBINATION
ECCENTRIC CONE REDUCER
AND DRIP STONE LANDING
FOR 60" & 120" DIA. MANHOLES

PLATE

104

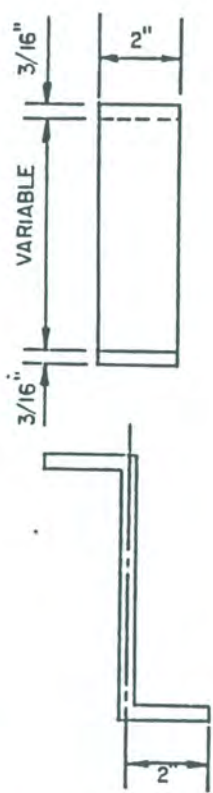
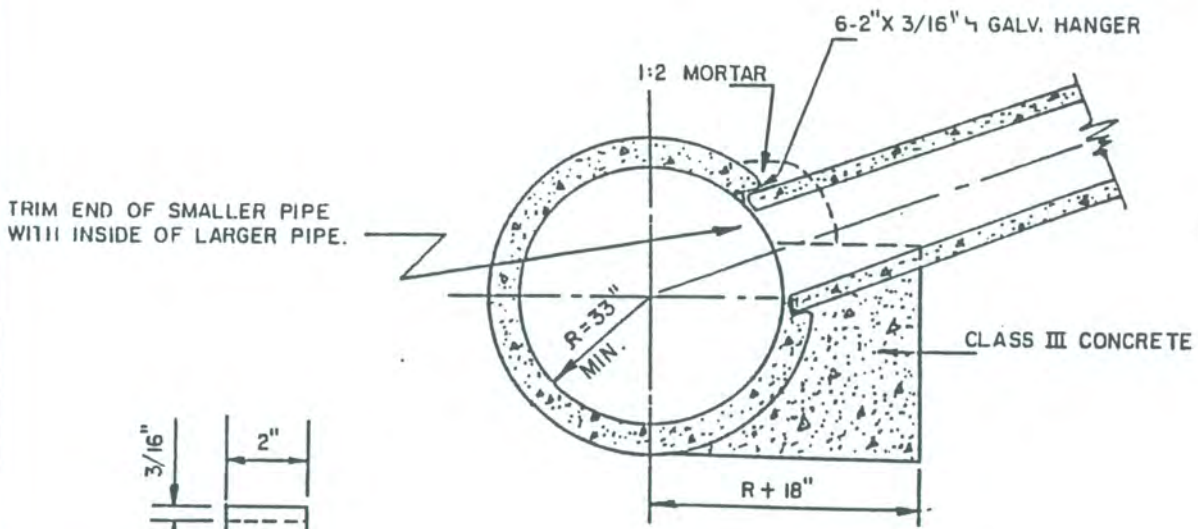

PIPE HANGER

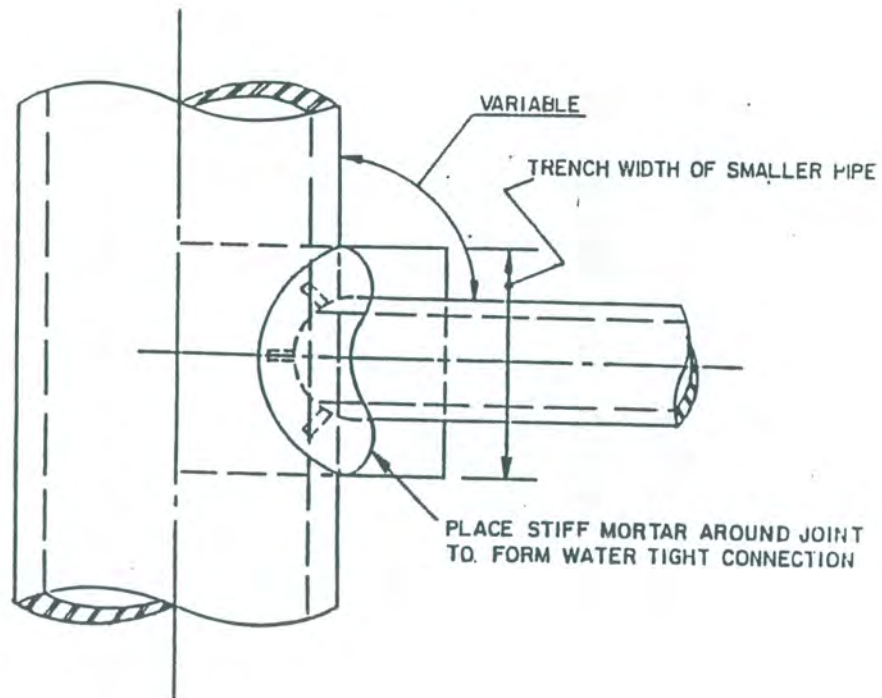

NOTES:

1. MINIMUM INSIDE DIAMETER OF LARGER PIPE = 33"
2. MINIMUM RATIO OF SMALLER PIPE DIAMETER TO LARGER PIPE DIAMETER = 0.45
3. ONLY ONE FIELD CONNECTION PERMITTED IN A SINGLE LENGTH OF LARGER PIPE.
4. SEE SECTION 6.4.5 OF THE "STORM DRAINAGE CRITERIA" (IN THIS MANUAL) FOR DIRECTIVES IN USING THIS METHOD.

REVISED	
DATE	BY

CARROLL COUNTY, MARYLAND
DEPARTMENT OF PUBLIC WORKS

[Signature] 4-12-94
DIRECTOR DATE

FIELD CONNECTION

PLATE